

PECASA REGALSYSTEM

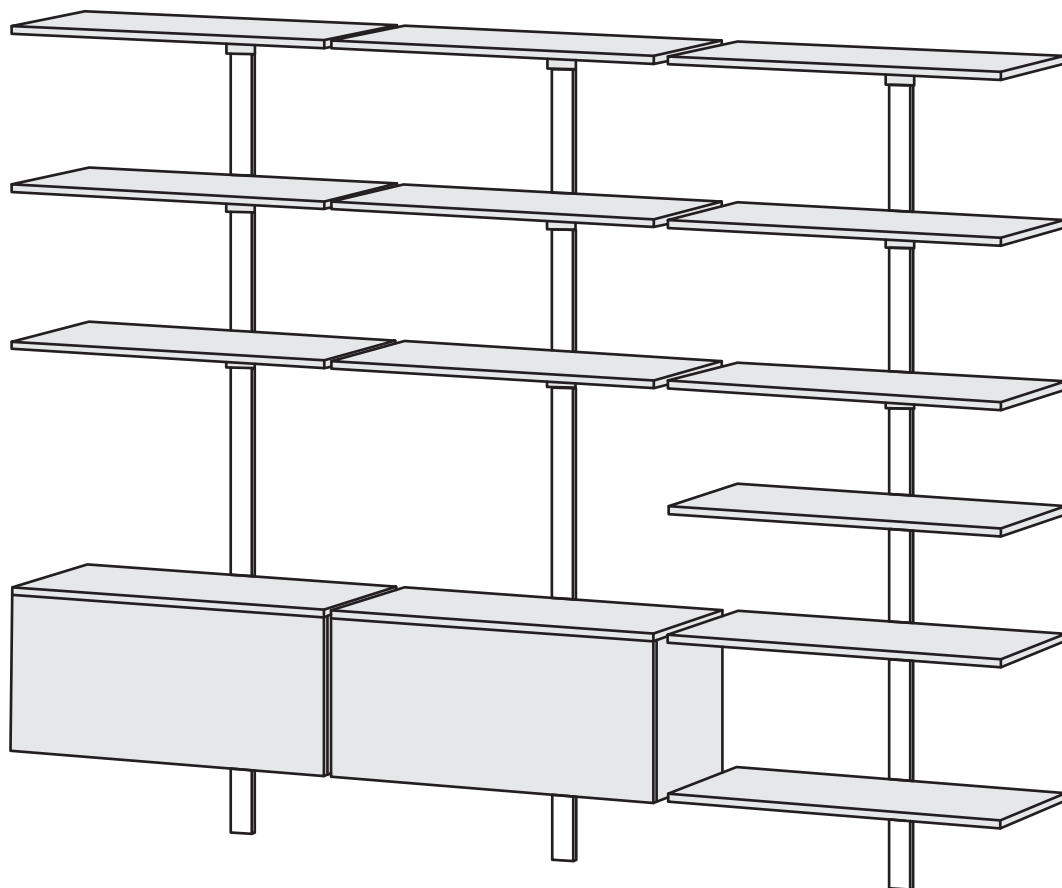

Pecasa système d'étagères
Pecasa shelf system





D Für Pecasa ist eine fachkundige Montage erforderlich, denn unsachgemäße Montage kann zu Unfällen führen; Möbel/Gegenstand könnte kippen oder umfallen. **WICHTIG!** Schrauben oder Beschläge zur Wand-/Deckenbefestigung sind nicht beige packt. Achten Sie darauf, dass Sie Schrauben/Beschläge entsprechend der Wandbeschaffenheit und mit ausreichender Tragfähigkeit verwenden. Erkundigen Sie sich gfs. beim Eisenwarenfachhandel.

FR Montage professionnel requis. Un montage incorrect peut entraîner des accidents ; les meubles / objets peuvent basculer ou tomber. **IMPORTANT !** Les vis ou les armatures pour la fixation au plafond / murale ne sont pas comprises. Veuillez à utiliser des vis / armatures adaptées à la constitution du mur et affichant une capacité de charge suffisante. Le cas échéant, renseignez-vous en quincaillerie.

E Expert assembly required. Improper assembly could cause accidents; furniture/objects could topple or fall over. **IMPORTANT!** The pack does not include screws or fittings for fixing the system to the wall/ceiling. Make sure that you use screws/fittings that are suitable for the wall's condition and have sufficient load-bearing capacity. If necessary, check at a hardware store.

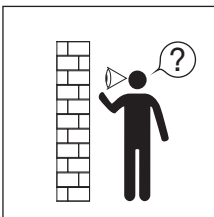

D Wandbeschaffenheit prüfen.
FR Vérifier la constitution du mur.
E Check wall condition.

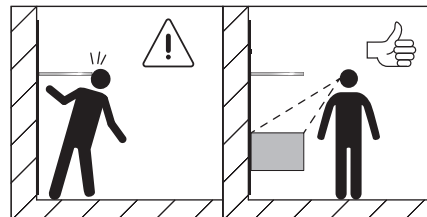

D ACHTUNG bei Montage eines Glastablers auf Augenhöhe! Aus Gründen der Sichtbarkeit immer einen massiven Körper darunter montieren.
FR ATTENTION en cas de montage d'une étagère en verre à la hauteur des yeux ! Pour des raisons de visibilité, toujours monter un caisson massif au-dessous.
E CAUTION: If mounting a glass shelf at eye level, always fit a large cabinet or box underneath it to boost its visibility.



D Beratung durch Fachpersonal.
FR Conseils par des professionnels.
E Consult a professional.

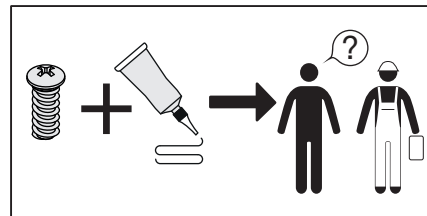

D Montage mit Kleber vom Fachmann abklären.
! Muss für den vorgesehenen Verwendungszweck geeignet sein.
FR Se faire expliquer le montage avec de la colle par un professionnel. **!** Doit être adapté pour l'utilisation prévue.
E Consult a professional for advice about using glue for assembly. **!** The glue must be suitable for the intended use.

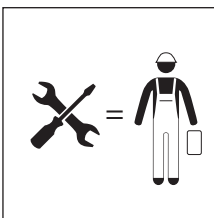

D Montage durch Fachpersonal.
FR Montage par des professionnels.
E Must be installed by a professional.

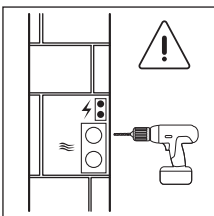

D Installationszonen prüfen.
FR Contrôler les zones d'installation.
E Check the installation area.

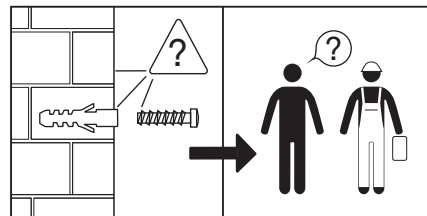

D Schrauben oder Beschläge zur Wandbefestigung durch Fachmann abklären lassen.
FR Se faire expliquer par un professionnel les vis ou les armatures pour la fixation murale.
E Consult a professional for advice about the screws or fittings to use to fix the system to the wall.



D Bei fehlerhafter Montage droht Gefahr durch herunter fallende Elemente.
FR En cas de montage erroné, des éléments risquent de tomber.
E If the system is not installed correctly, elements may fall down.



Bauart geprüft
Sicherheit
Regelmäßige
Produktions-
überwachung

www.tuv.com
ID 1111214942



Tablarträger-Set für Massivholz
 Jeu de supports d'étagère pour
 bois massif
 Shelf support set for solid wood
 shelves



Tablarträger-Set für Glas und Holzwerkstoffe
 Jeu de supports d'étagère pour verre et
 dérivés du bois
 Shelf support set for glass or wood-composi-
 te shelves

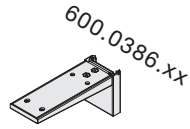
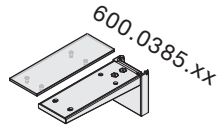

Möbelträger-Set
 Jeu de supports
 de meuble
 Unit support set

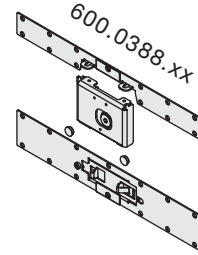

Wandprofil-Set
 Jeu de profils
 muraux
 Wall profile set

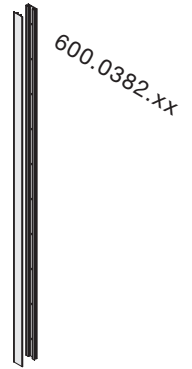

SHELF DIMENSIONS | TABLAR DIMENSIONEN | DIMENSIONS DE L'ÉTAGÈRE

Metalltablar-Set, inkl. Tablarträger
 Jeu d'étagères en métal avec supports
 Metal shelf set, including shelf
 supports

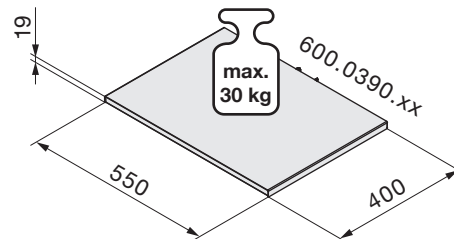
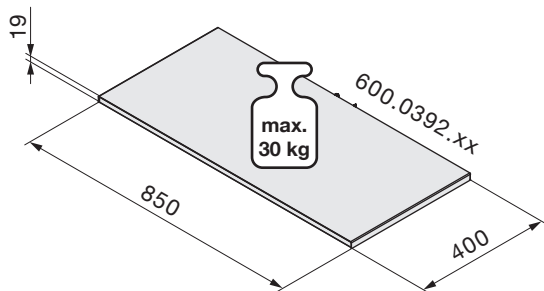
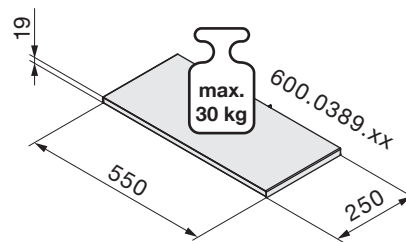
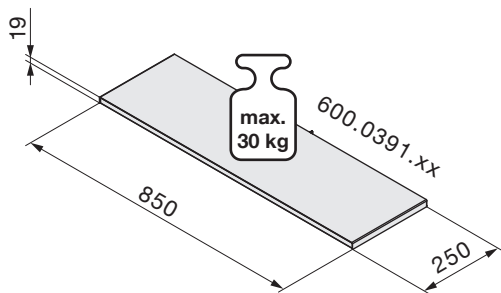

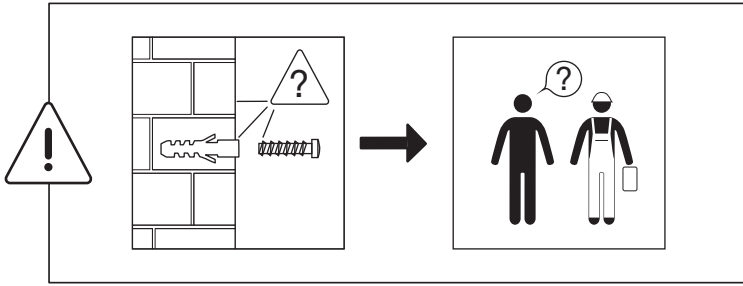

600.0382.XX

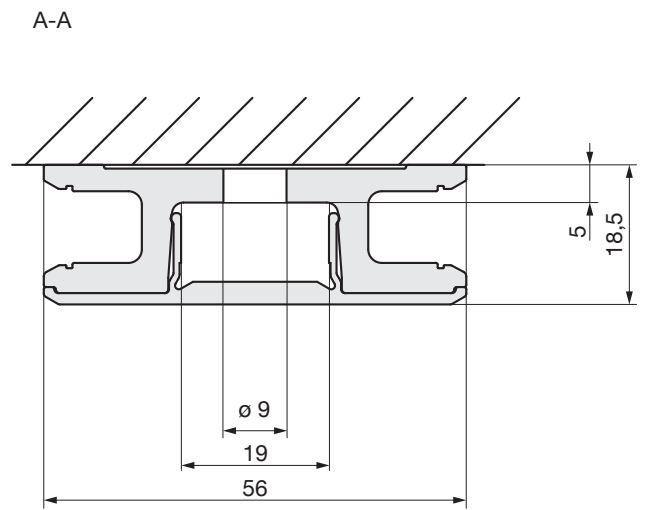
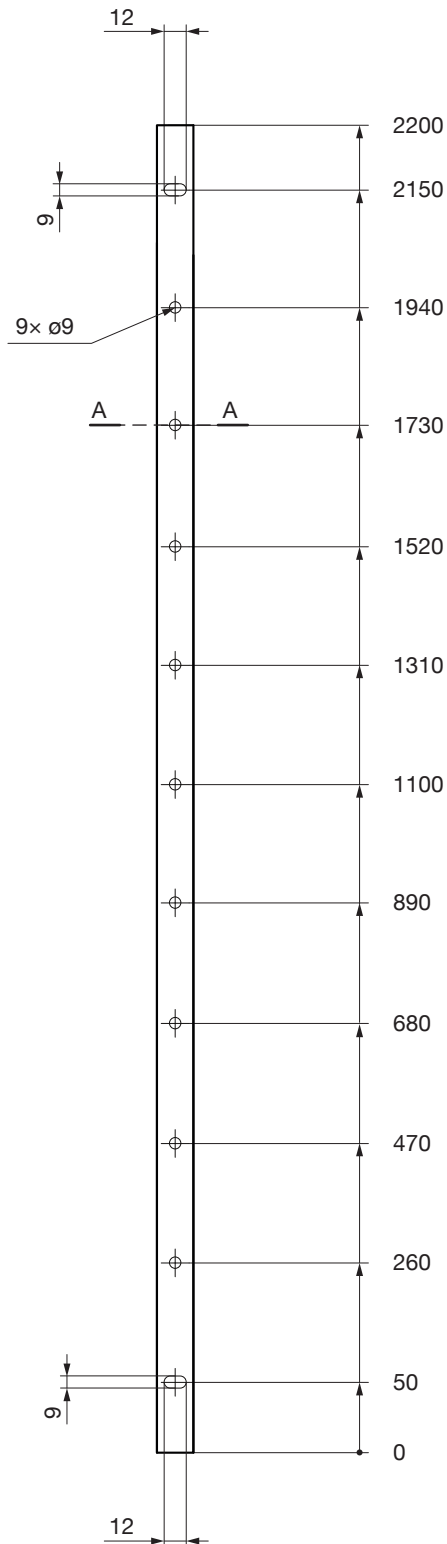

Tablar für Holzwerkstoffe
Étagère pour dérivés du bois
Wood-composite shelf

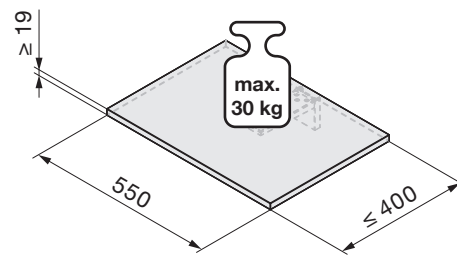
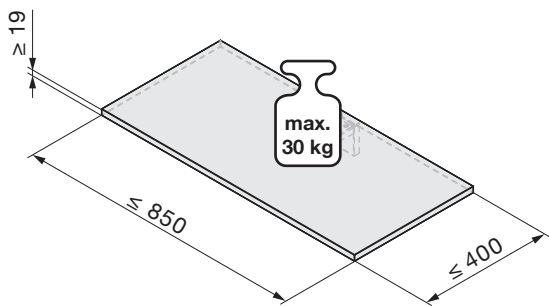
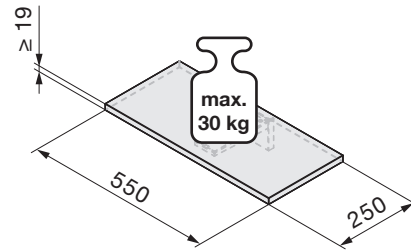
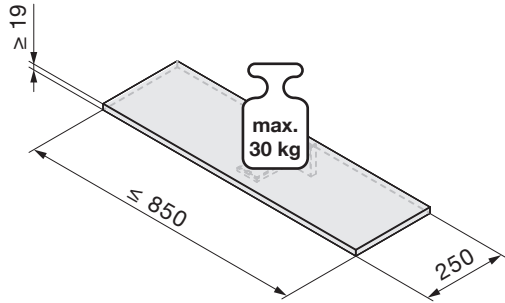

Glastablar
Étagère en verre
Glass shelf

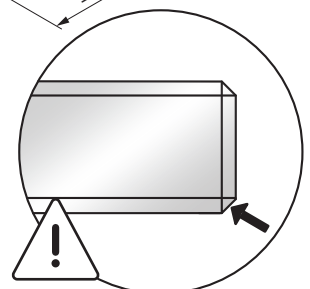
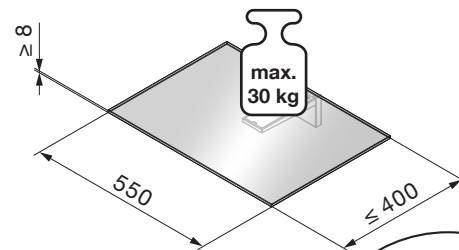
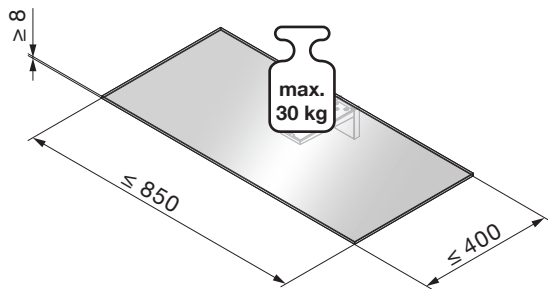
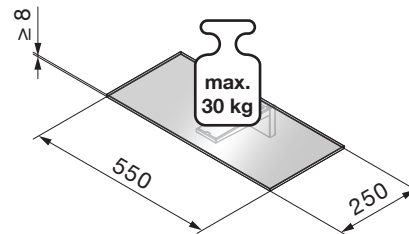
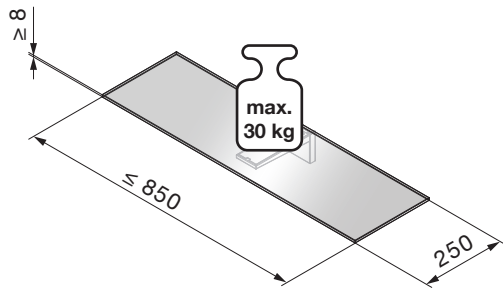

Korpus
Caisson
Cabinet

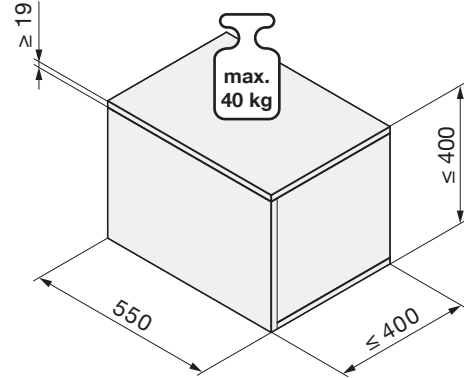
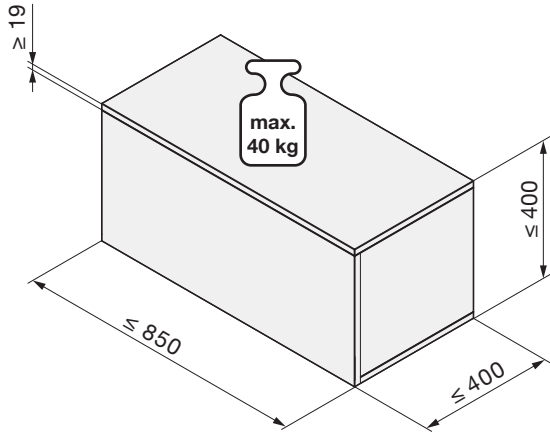

Fach
Compartment
Box

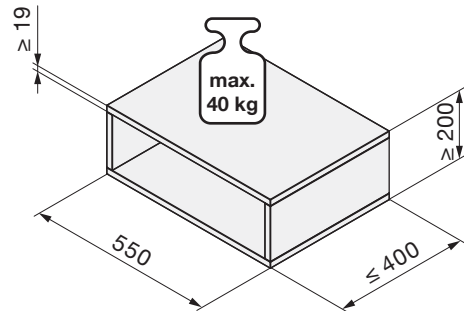
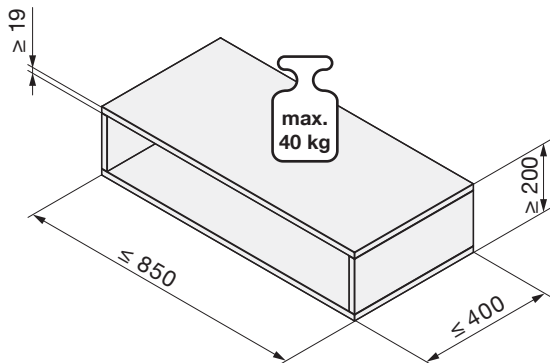

Office
Bureau
Office

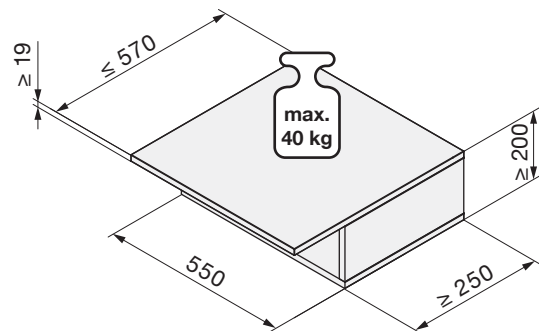
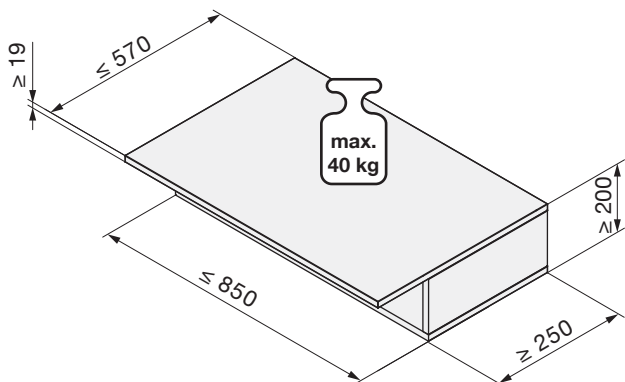

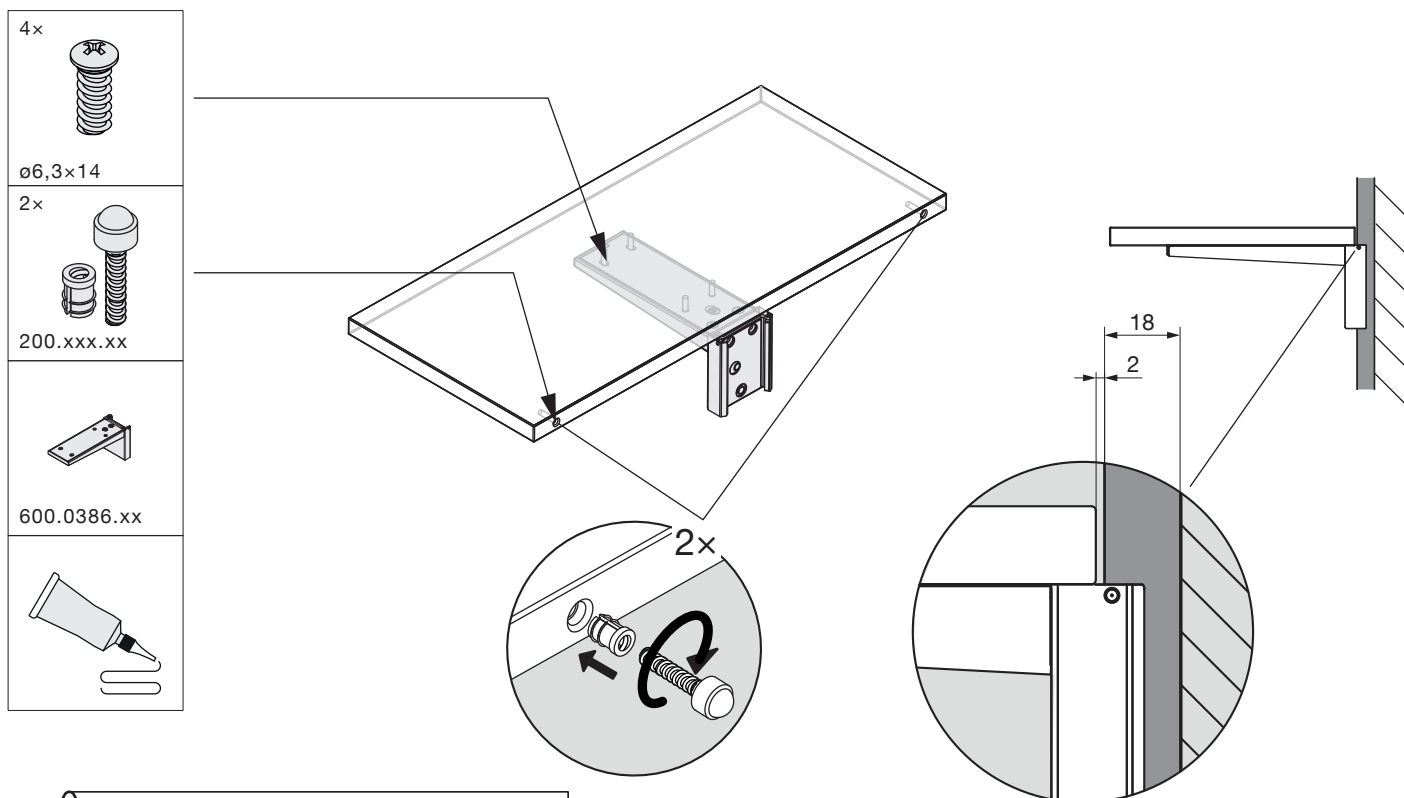

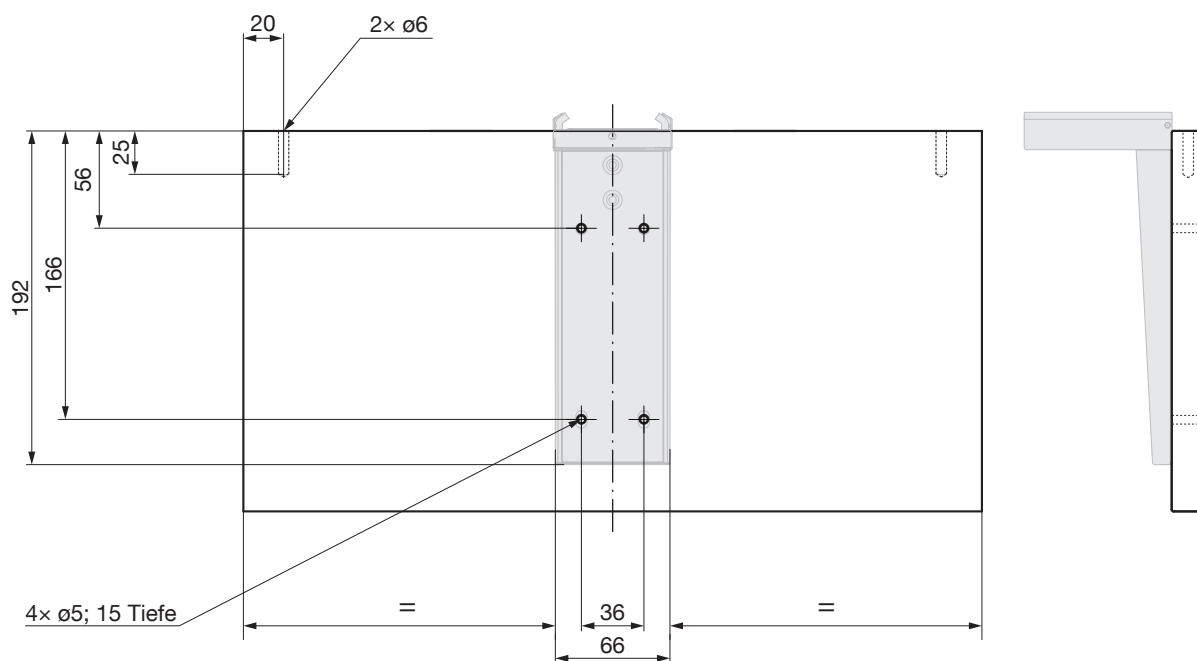
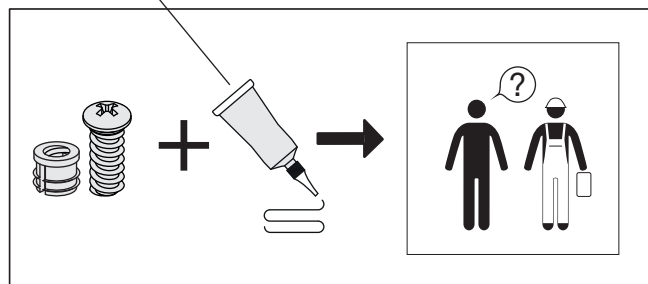

! Verwendungszweck: Holz + Metall
 Utilisation : bois + métal
 Suitable for use with wood + metal

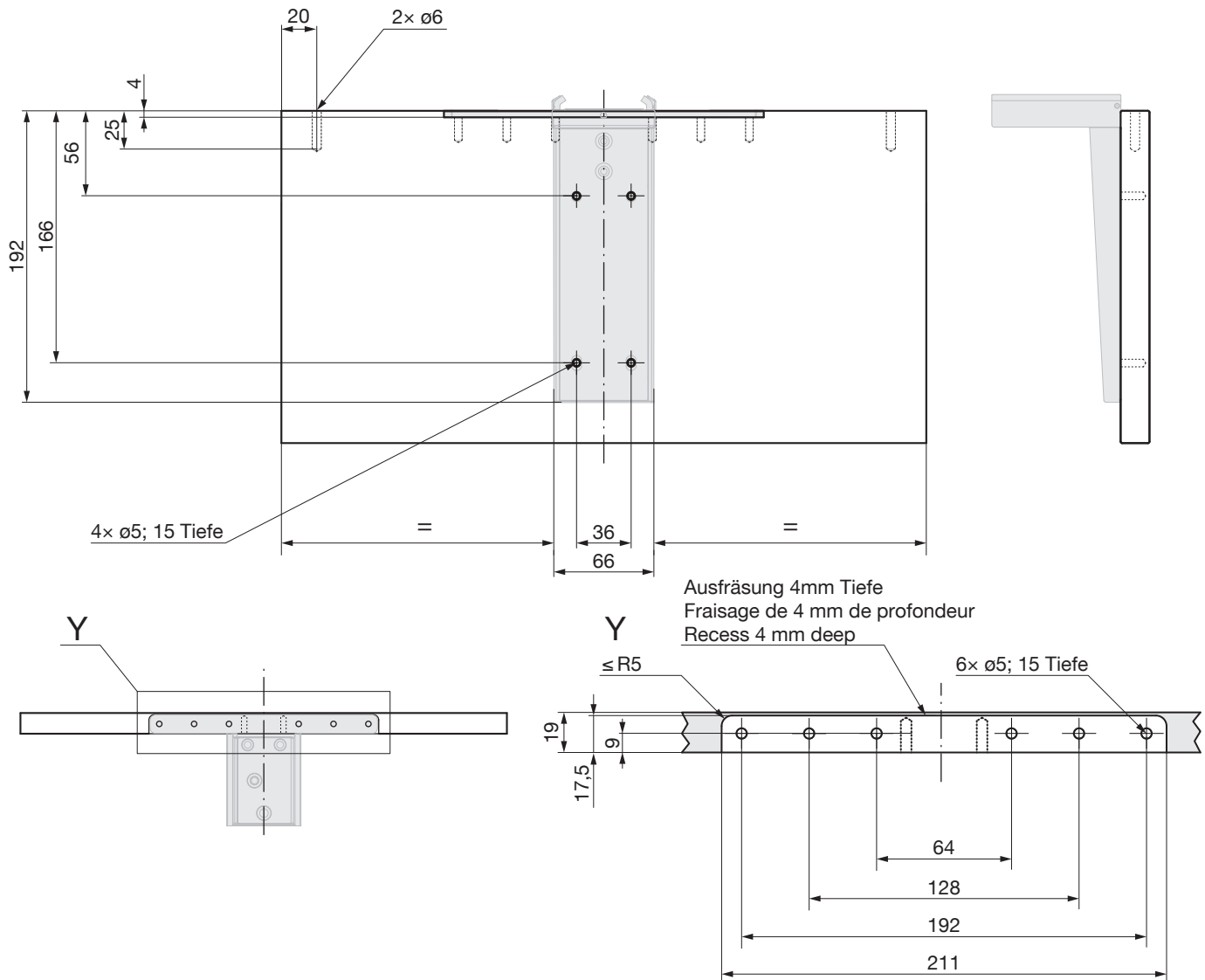
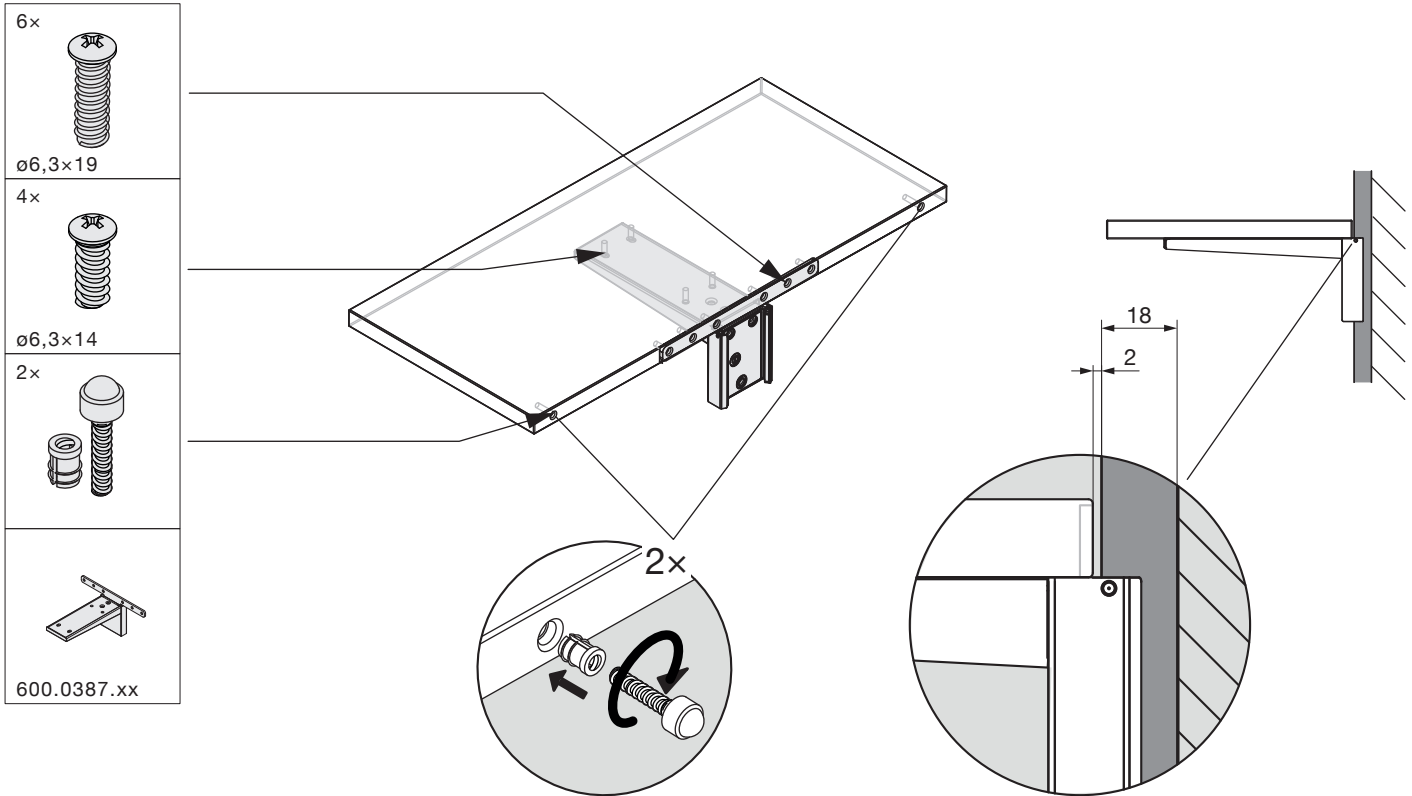

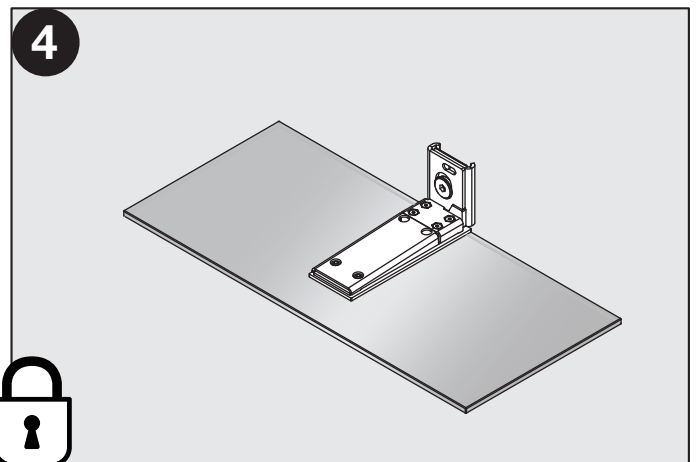
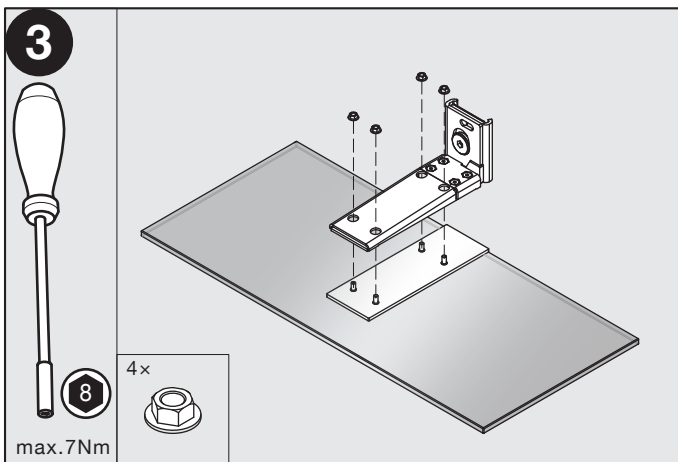
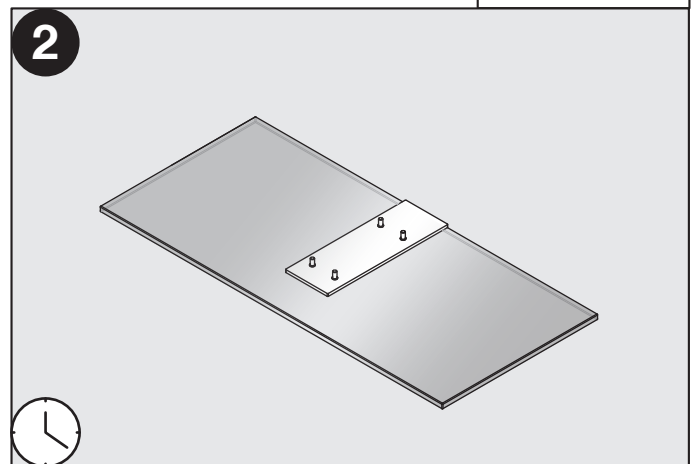
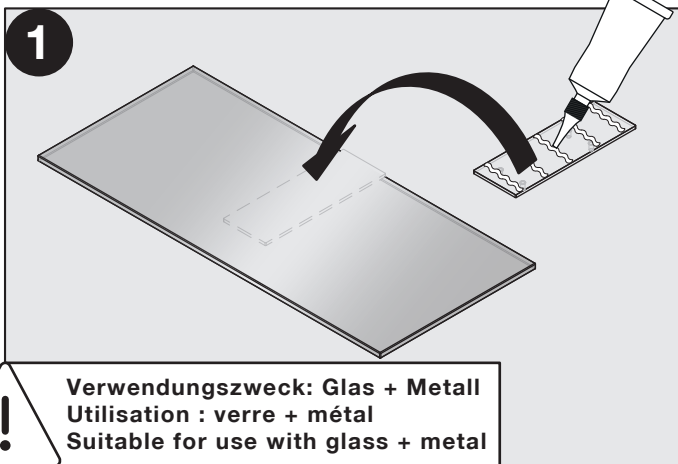
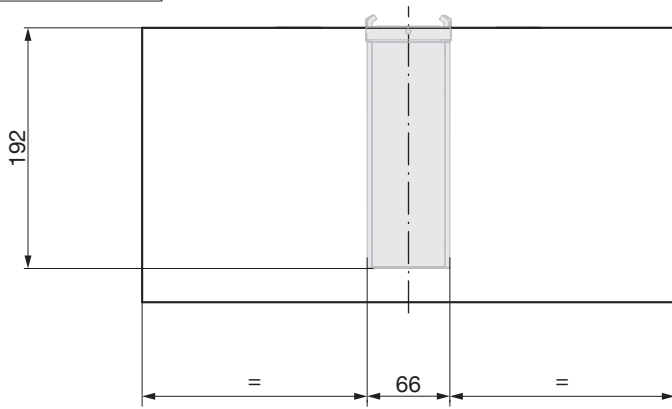
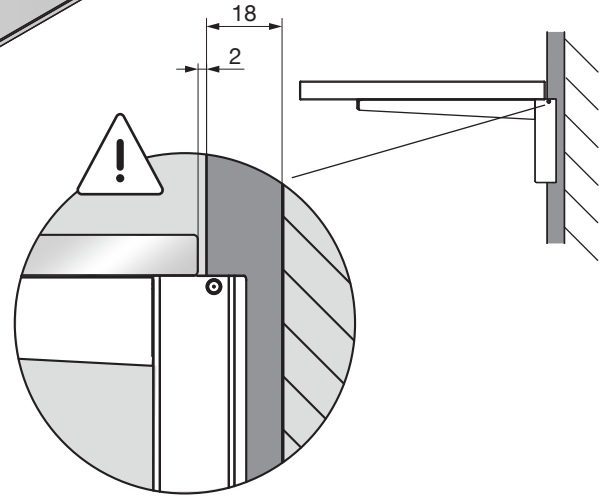
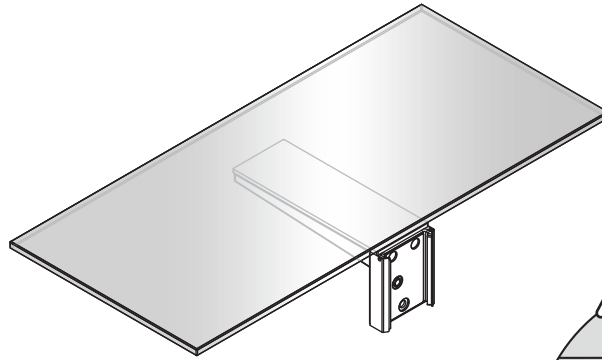
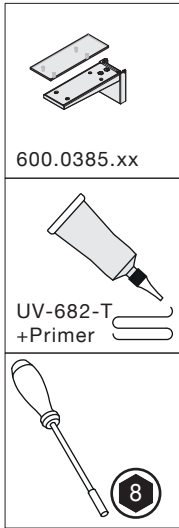

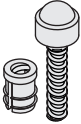
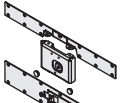

- 7x 
- ø6,3x25
- 20x 
- ø6,3x14
- 2x 
- 
- 600.0388.xx

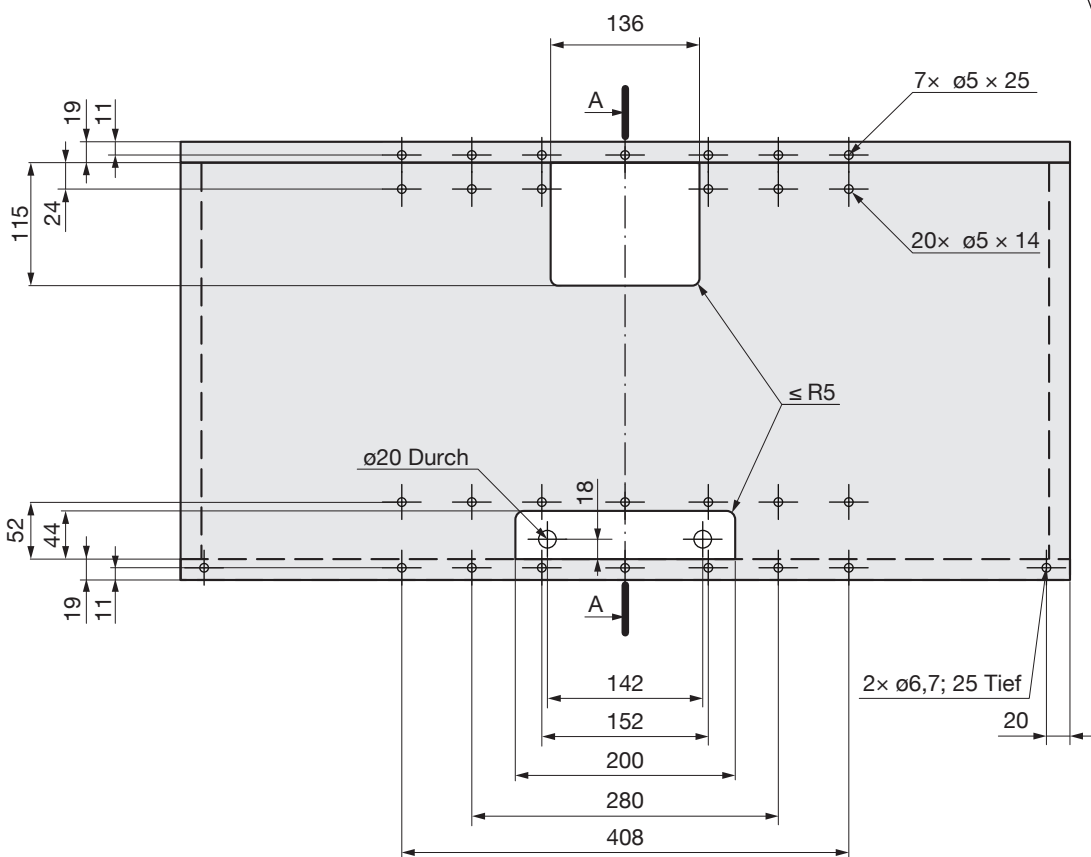
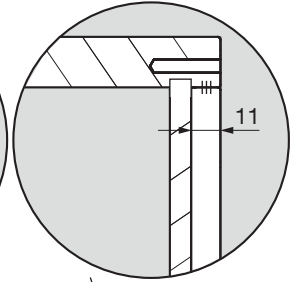
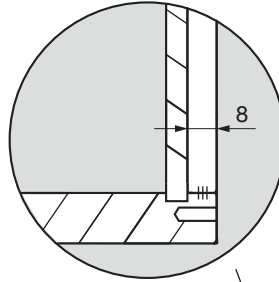
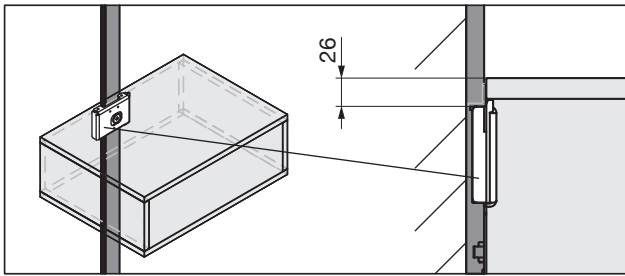
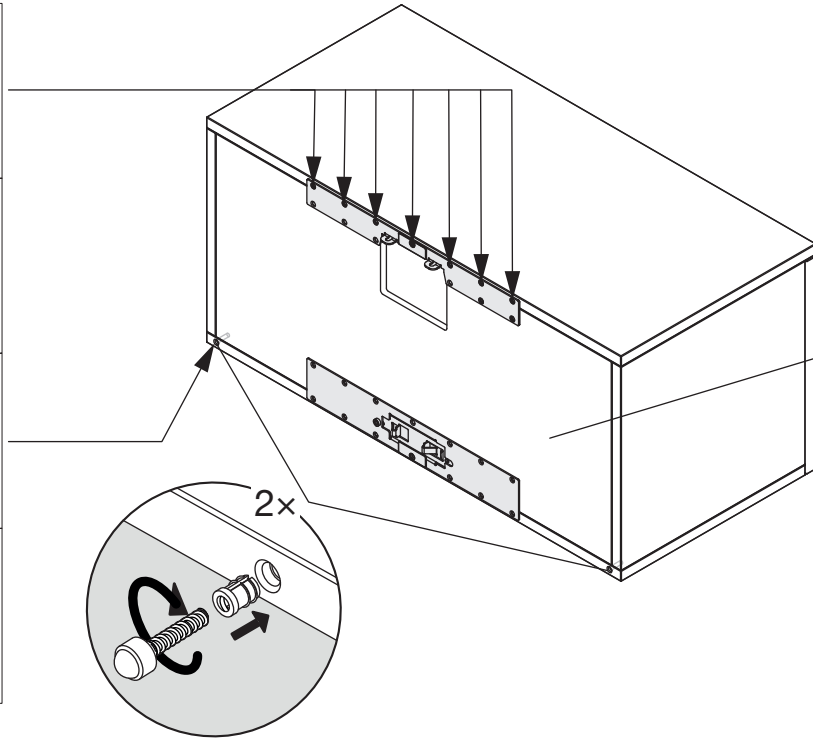

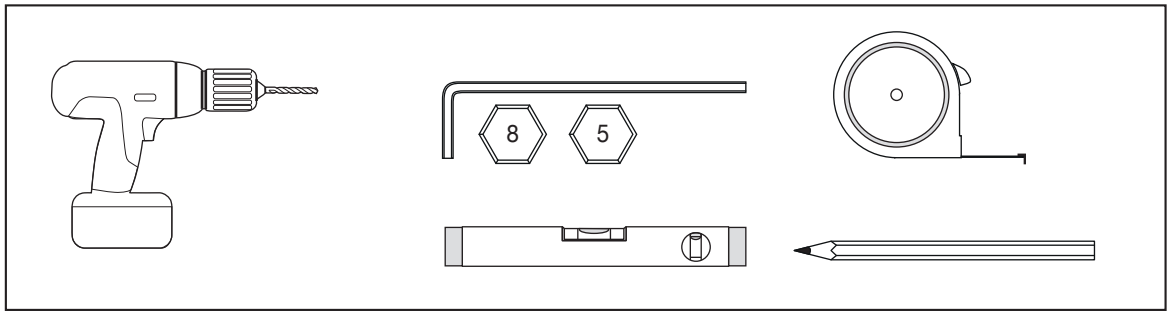
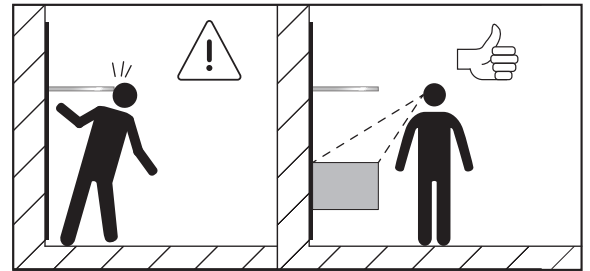
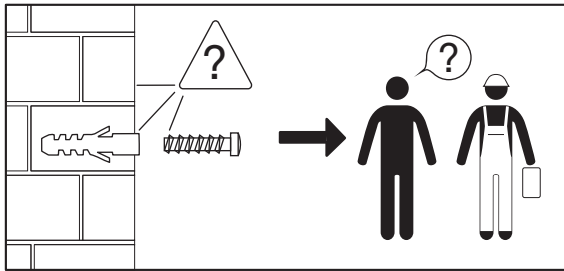
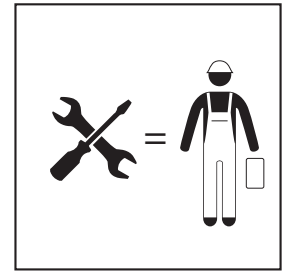
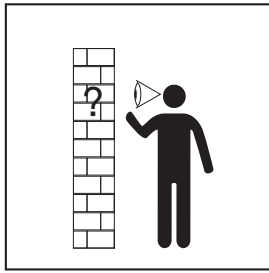

1

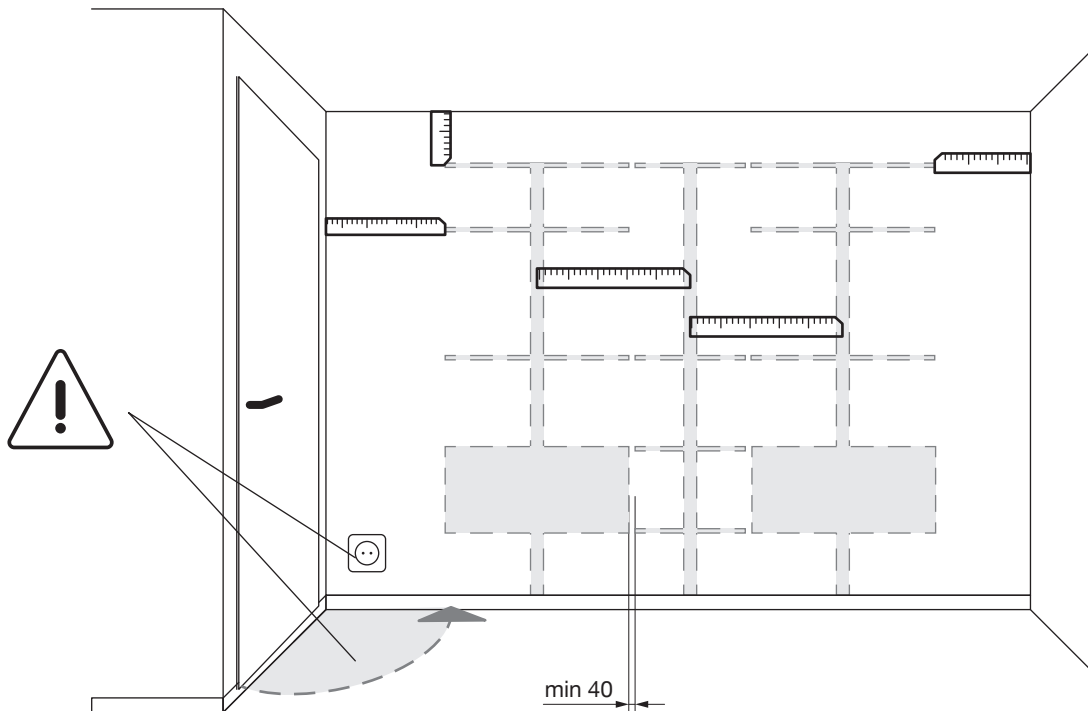

2

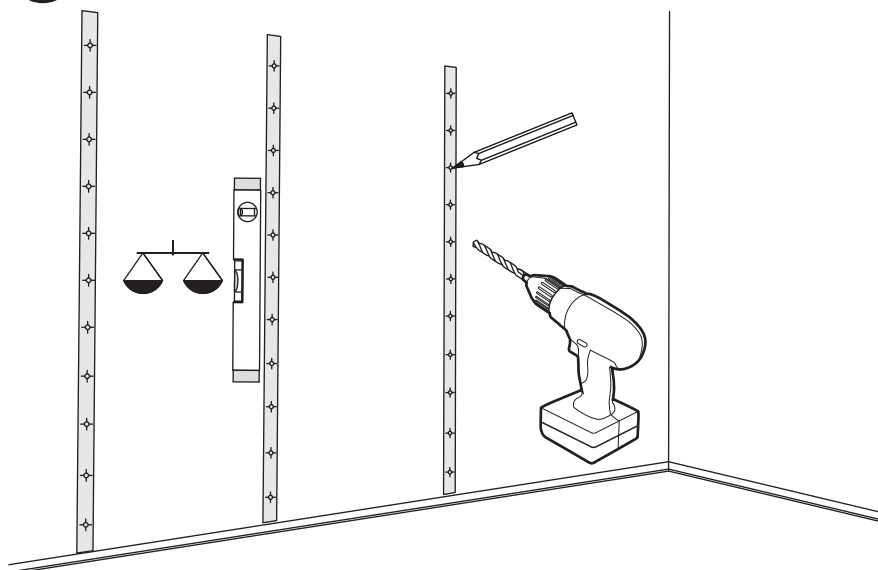

3

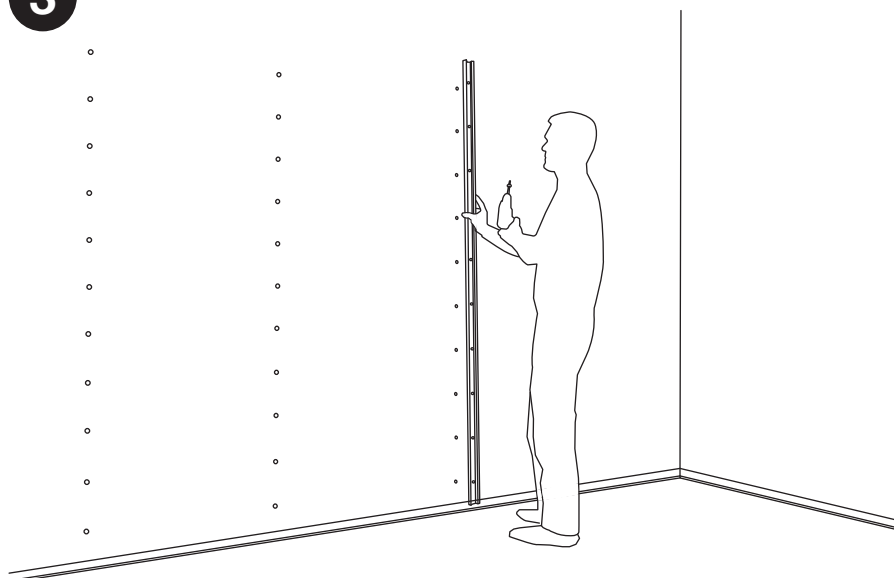

4

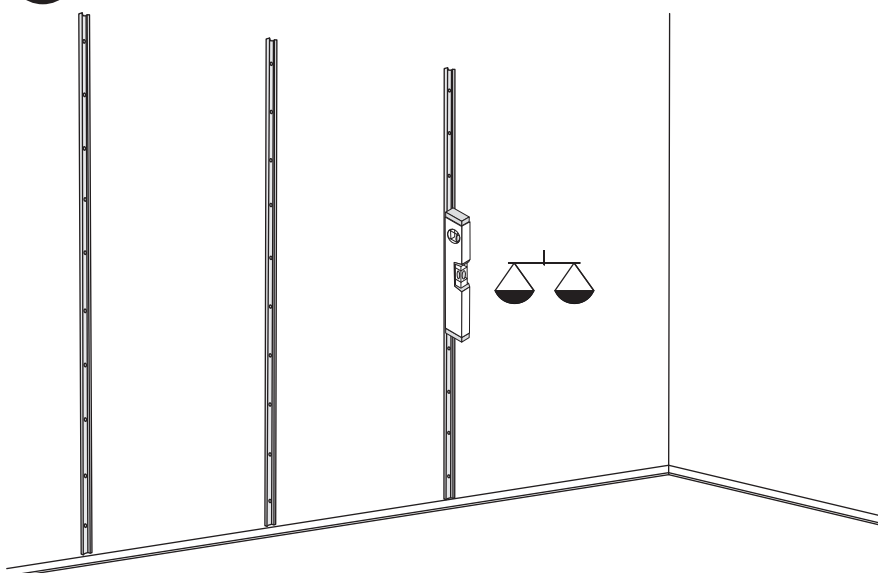

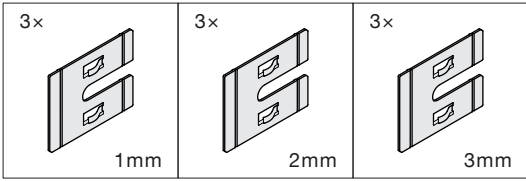

5

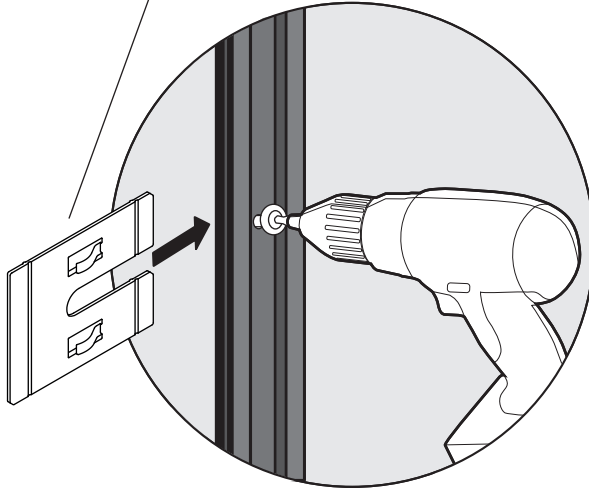
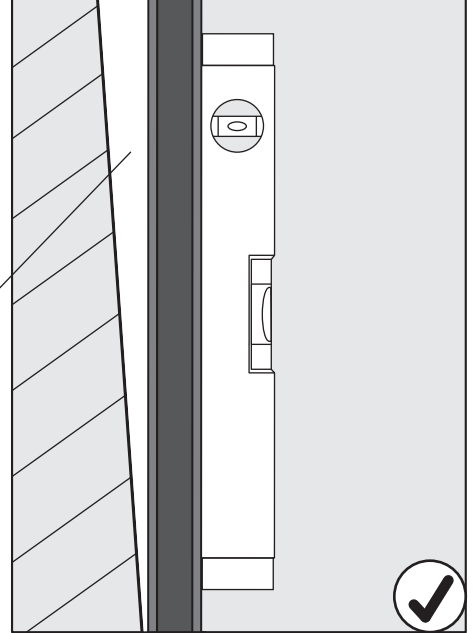
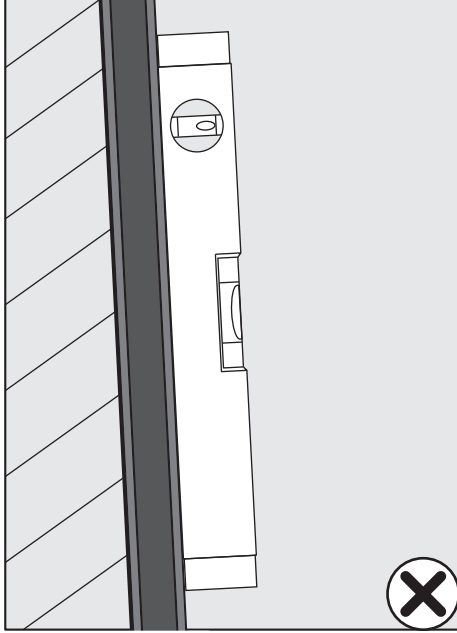

6

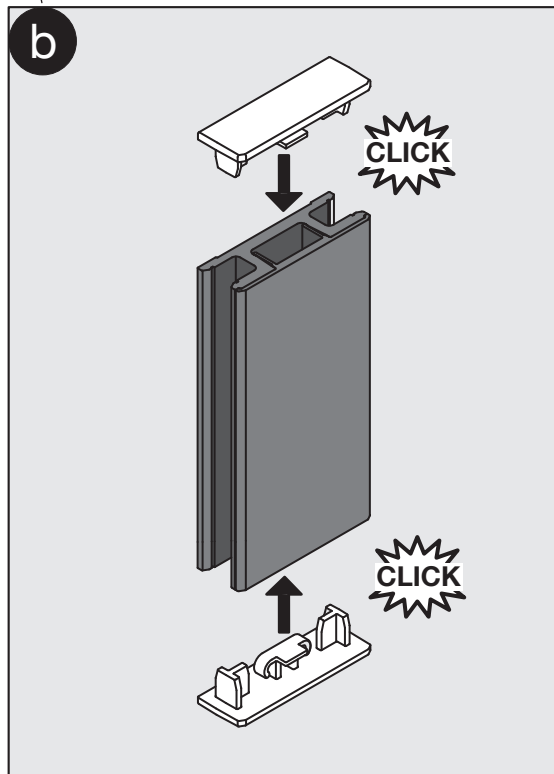
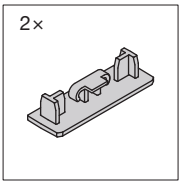
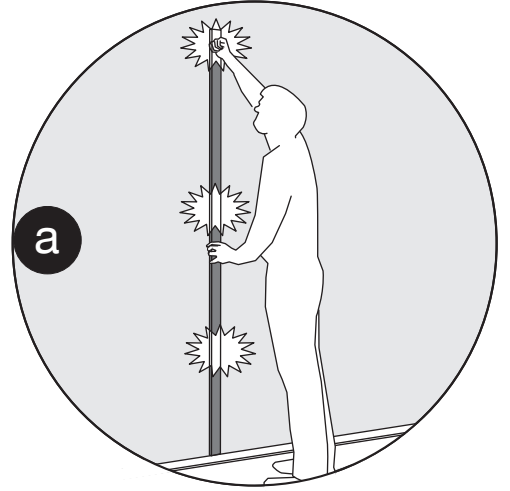
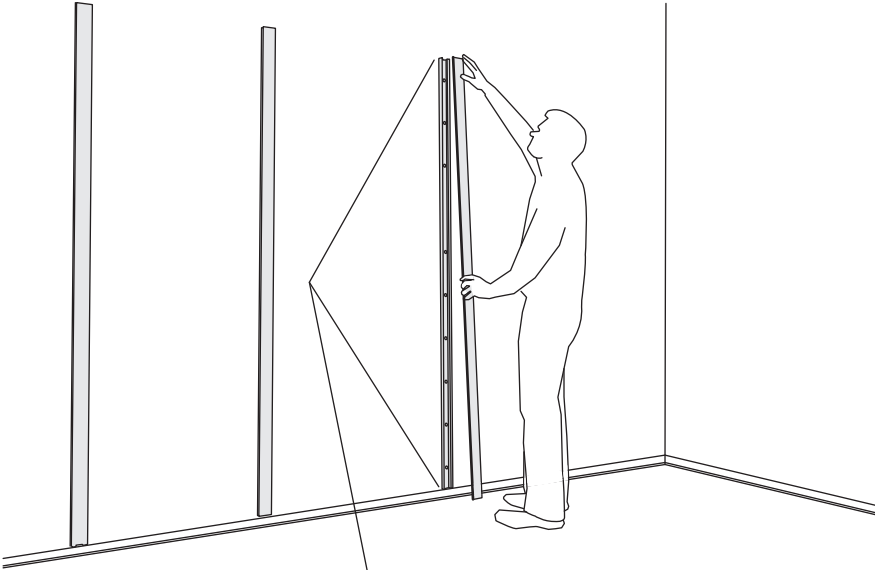

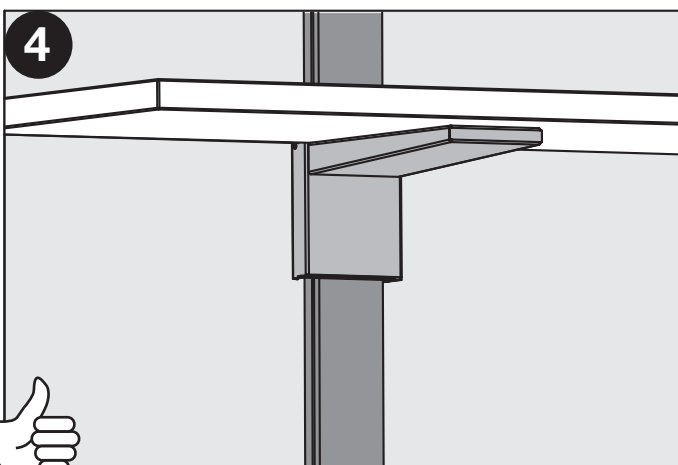
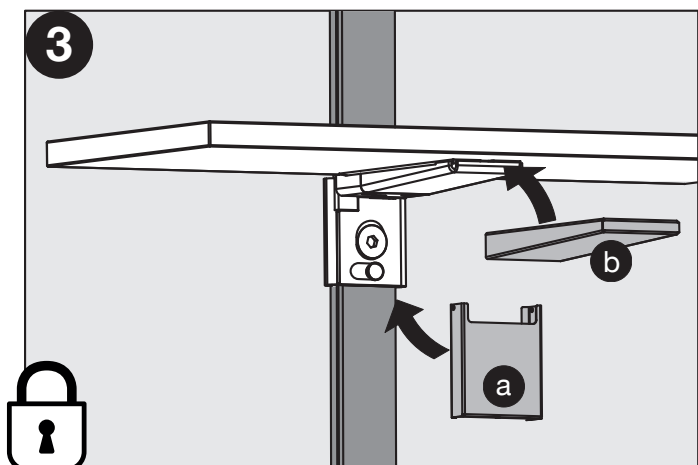
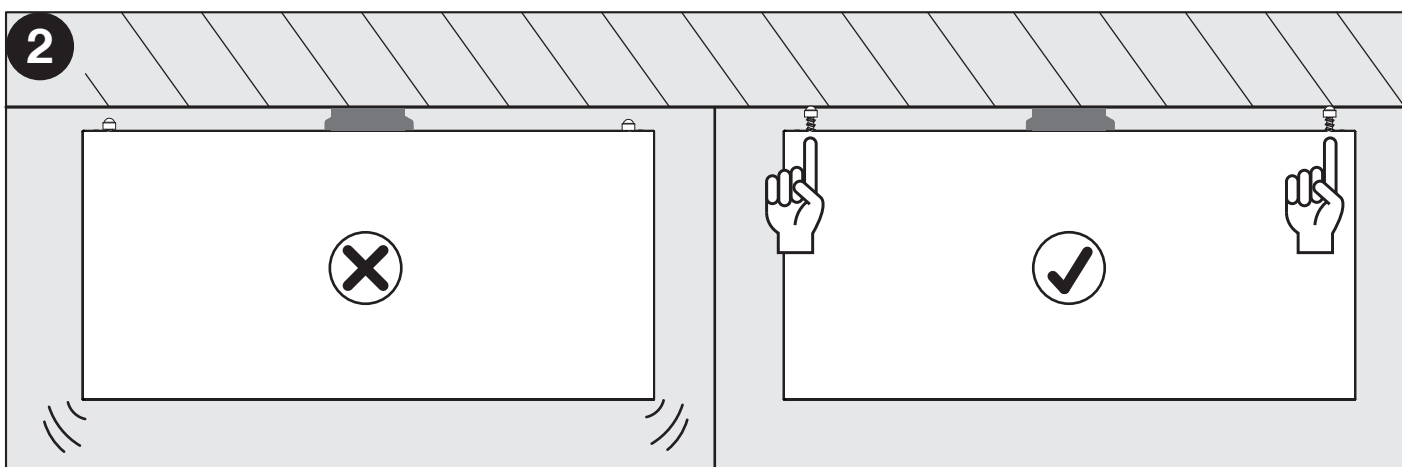
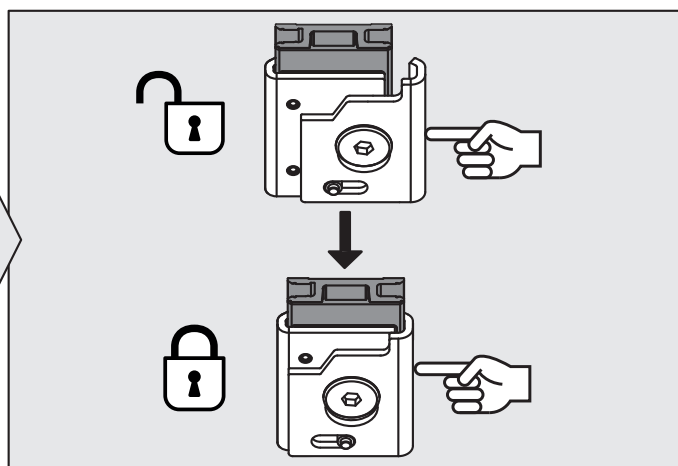
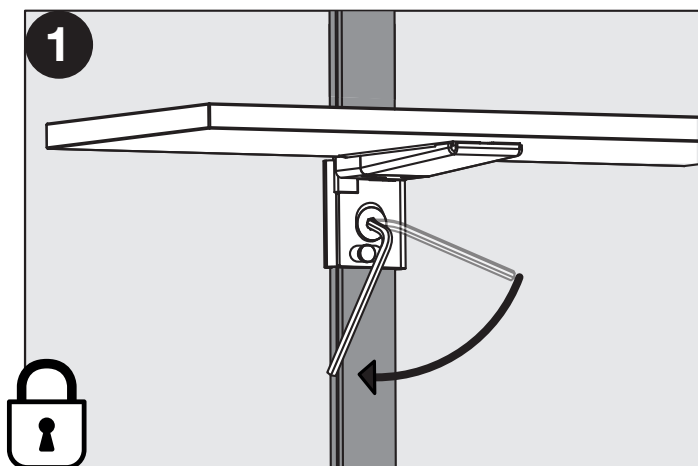
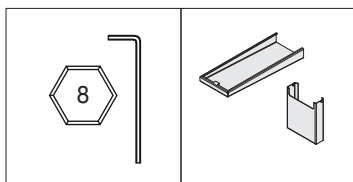

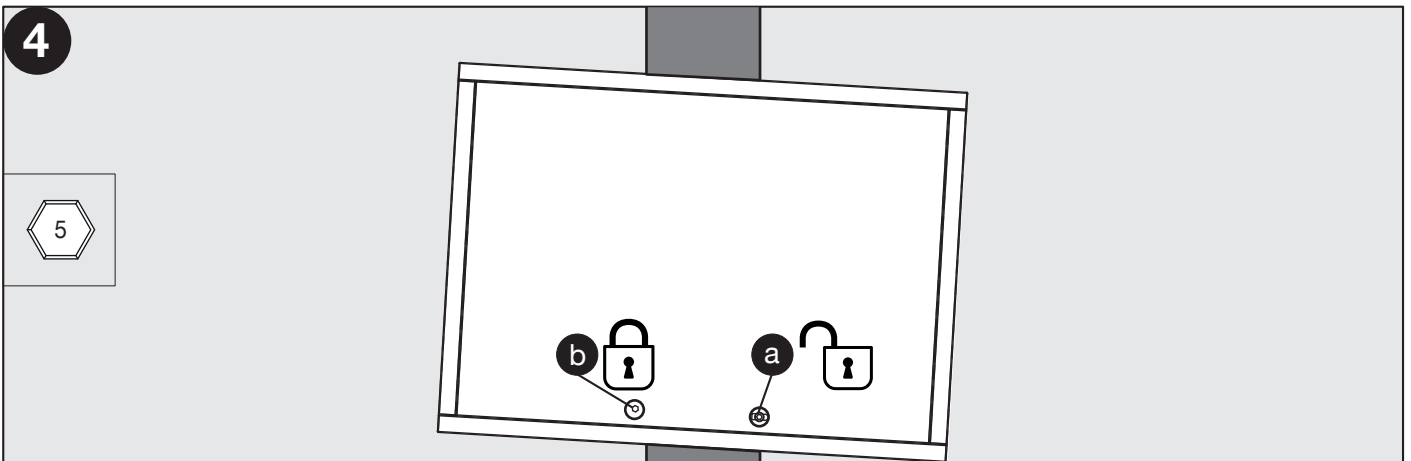
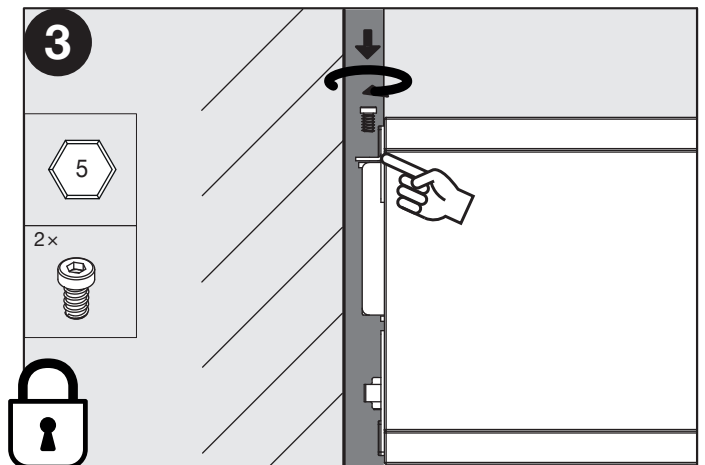
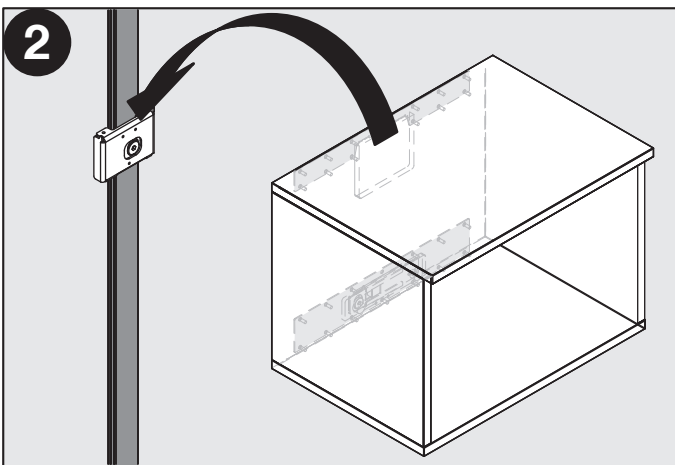
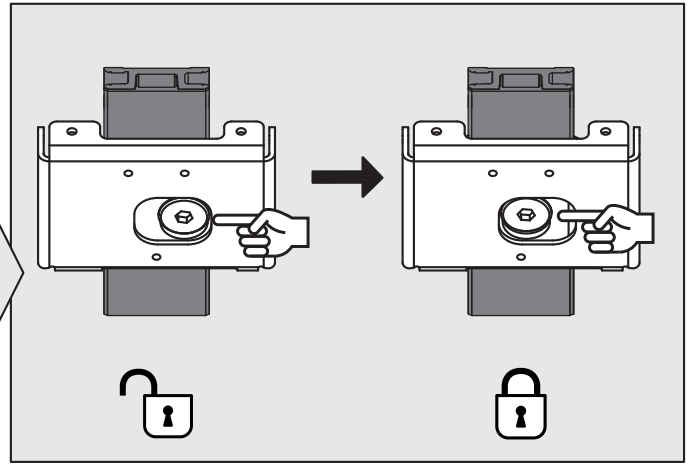
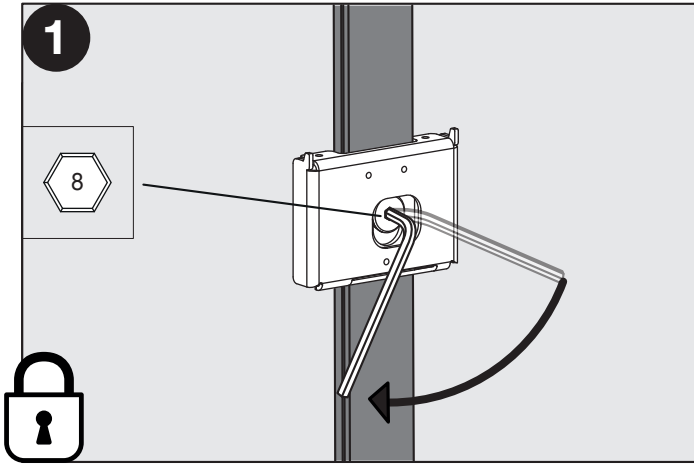
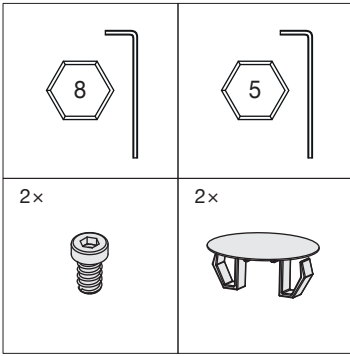

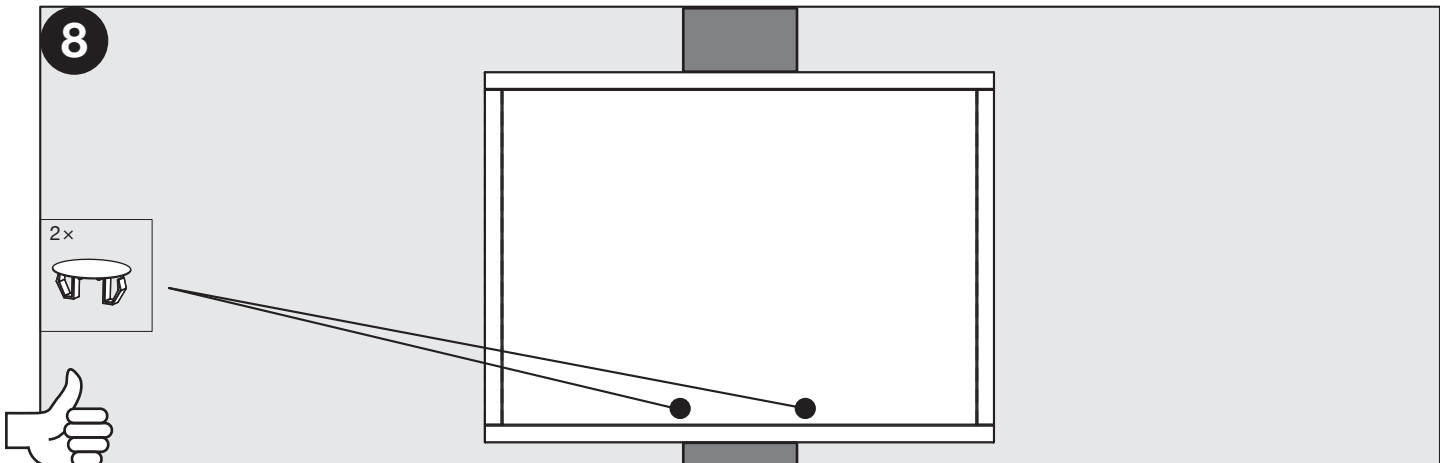
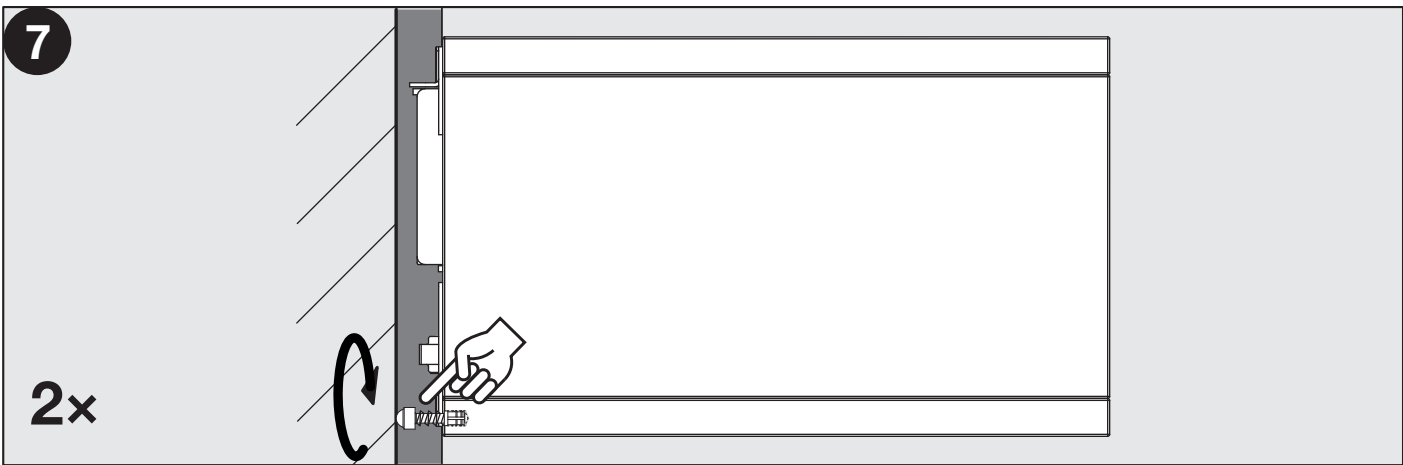
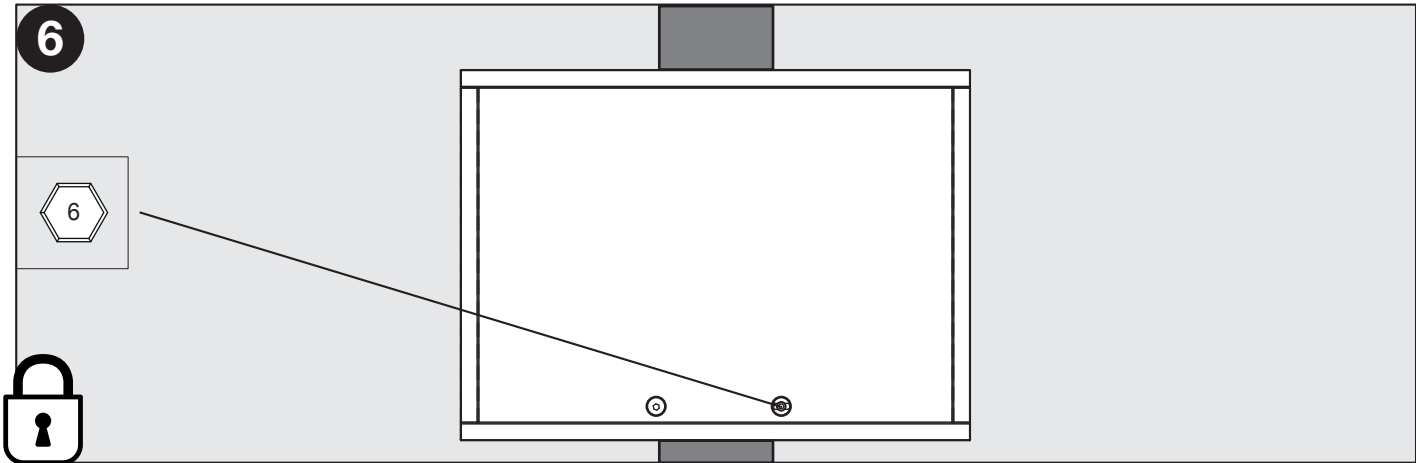
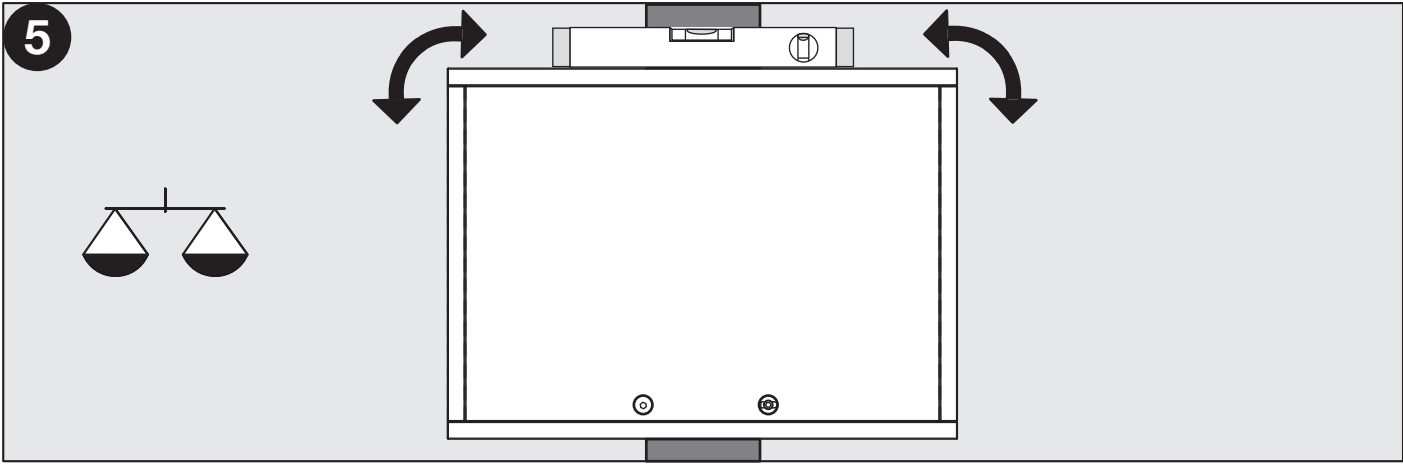

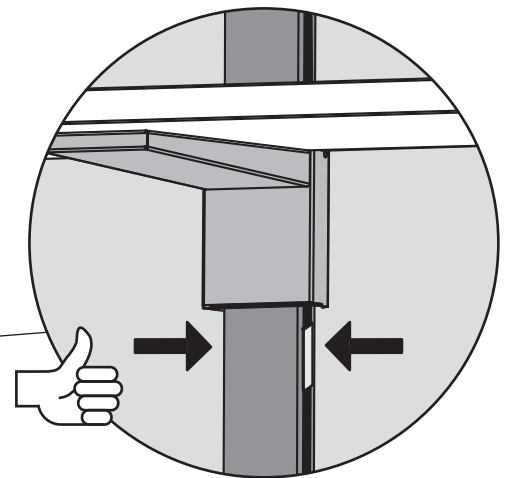
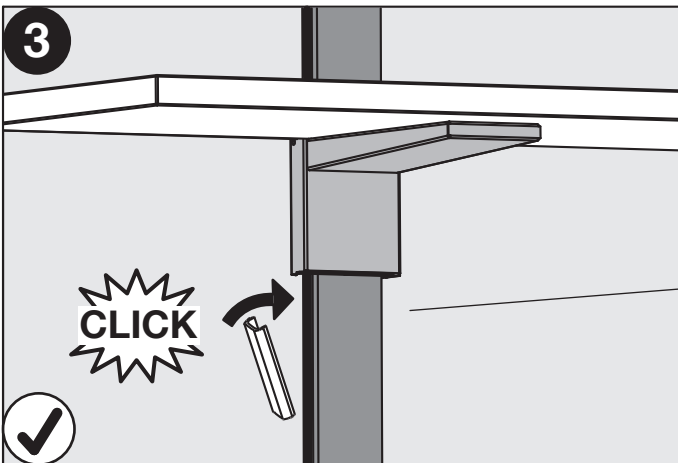
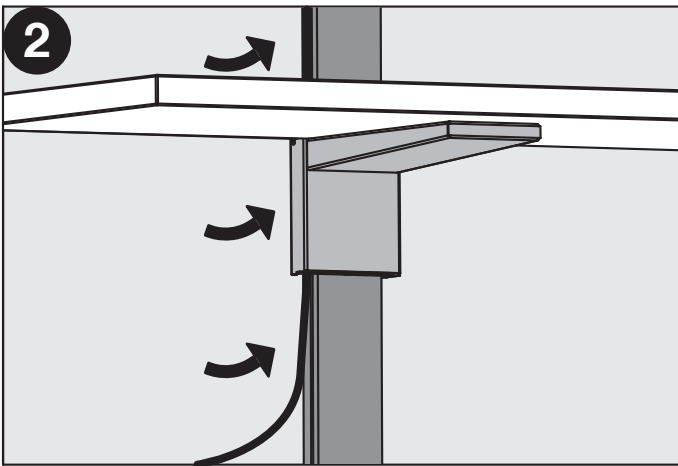
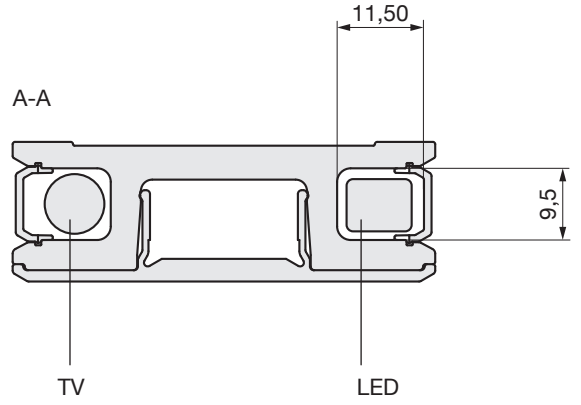
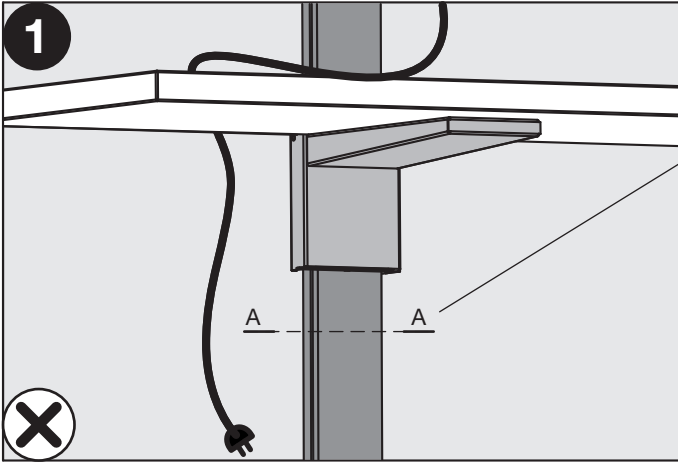
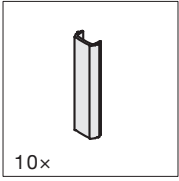



PECASA KLEIDERSTANGE

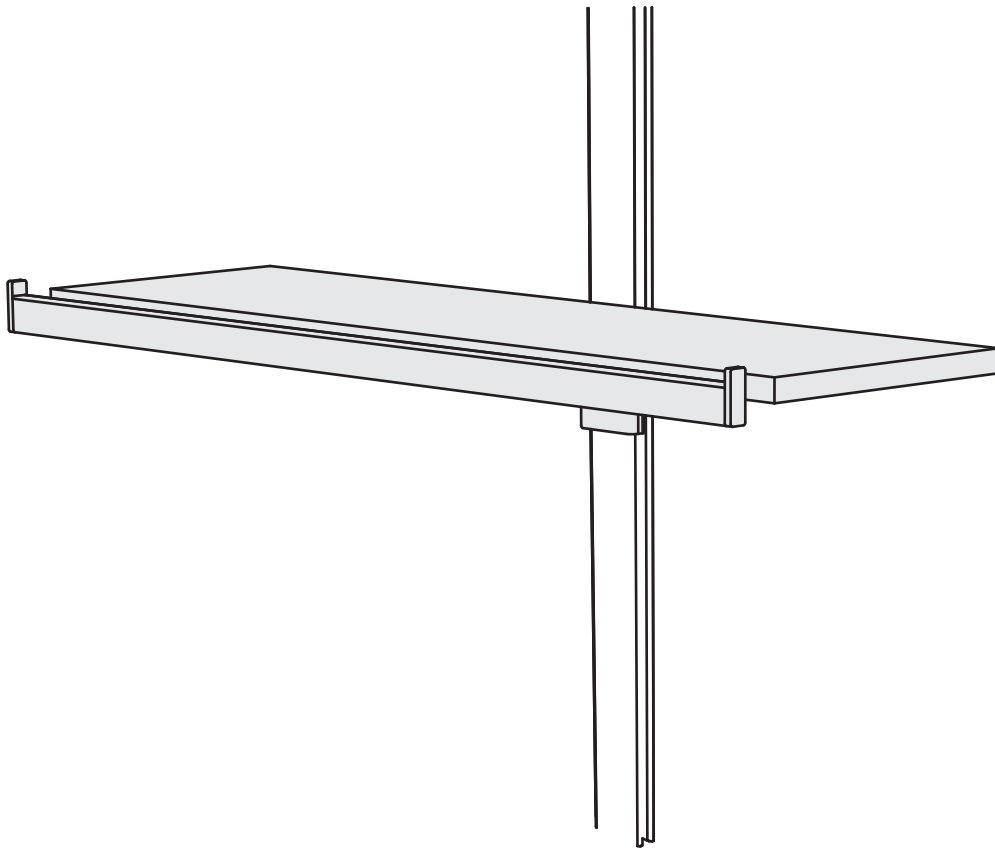

Tringle à vêtements Pecasa
Pecasa clothes rail

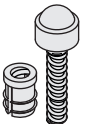
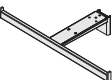
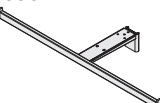

- 4x 
- ø6,3x14
- 2x 
- 550
- 
- 600.0393.xx
- 850
- 
- 600.0394.xx

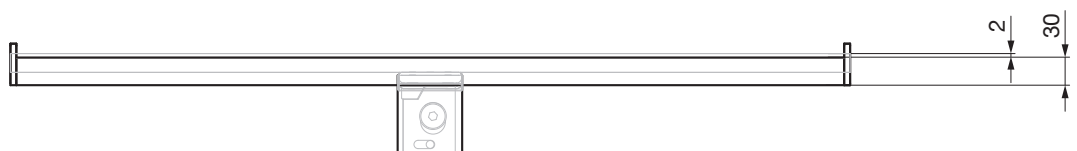
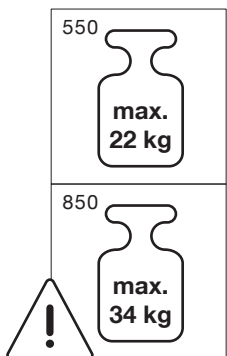
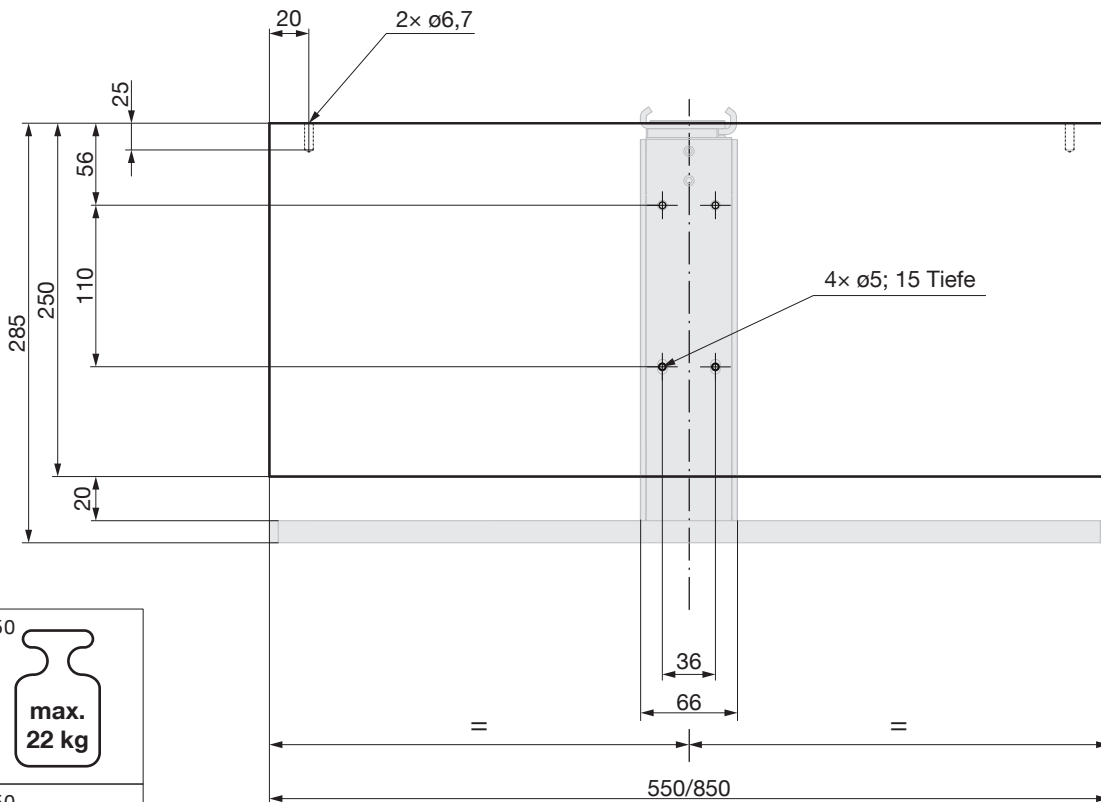
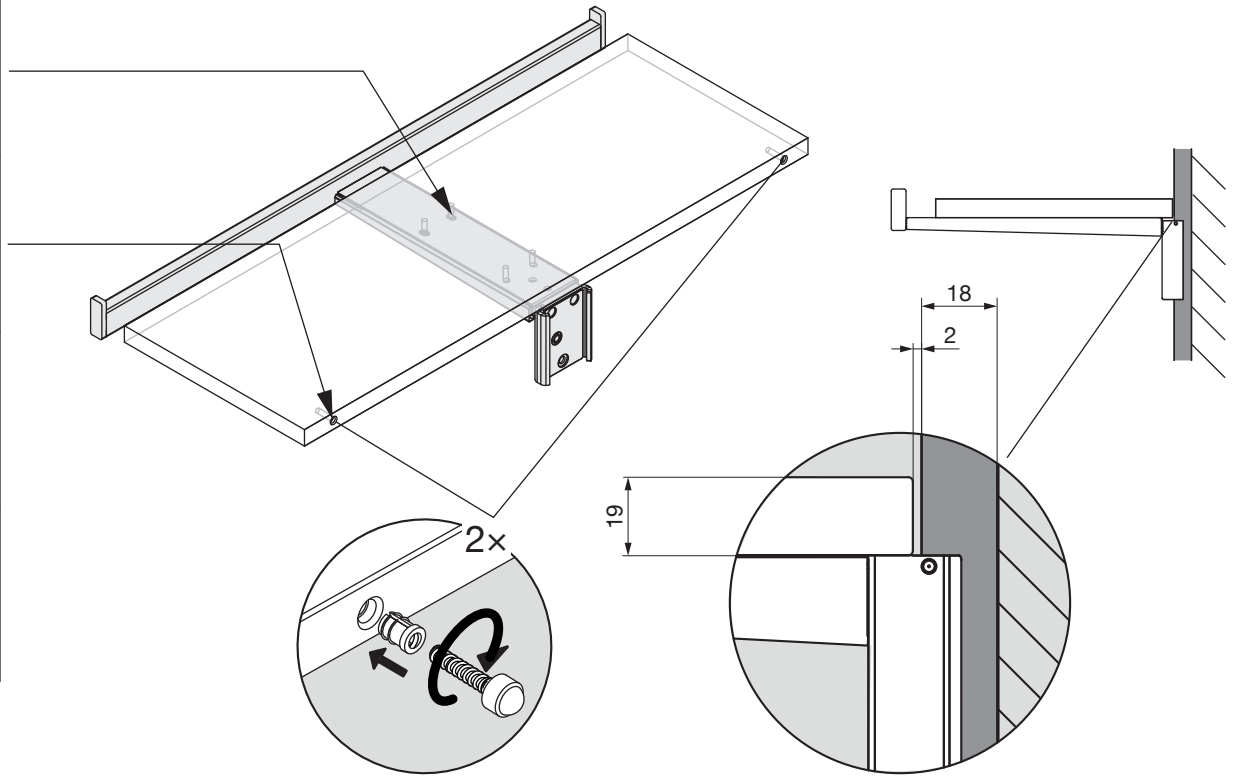

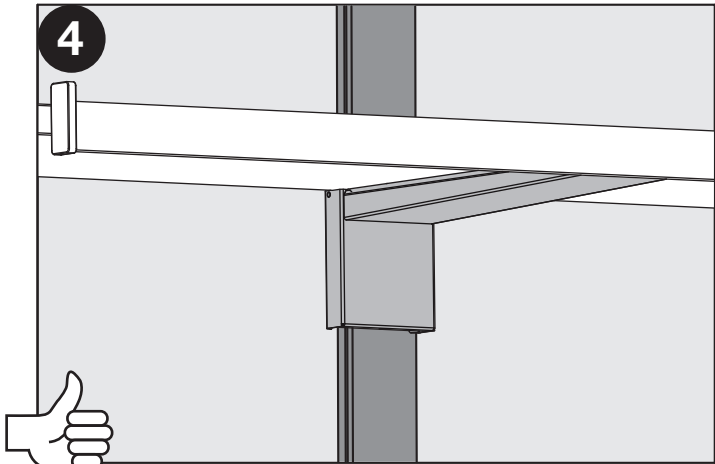
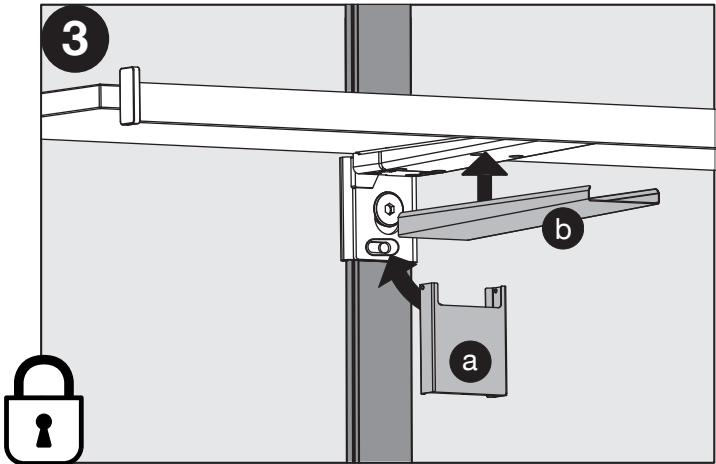
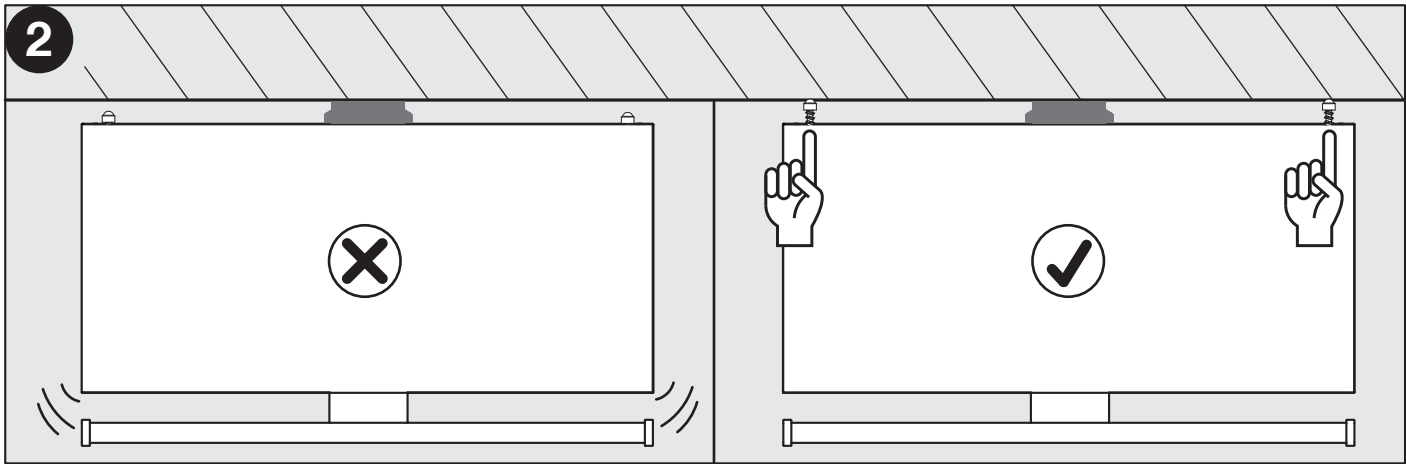
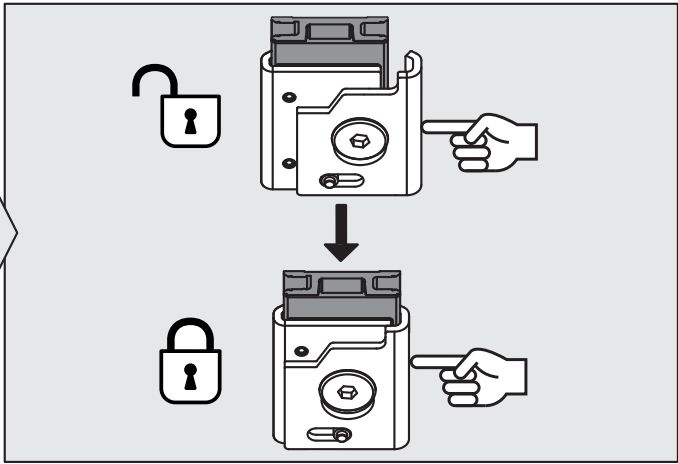
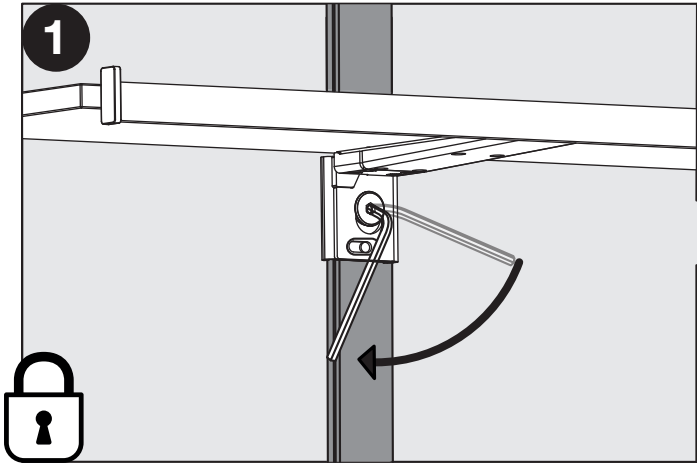
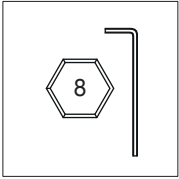

PECASA UNIVERSALTRÄGER FÜR SPIEGEL, TV

—

Support universel Pecasa pour miroir, téléviseur
Pecasa universal bracket for mirrors, TVs

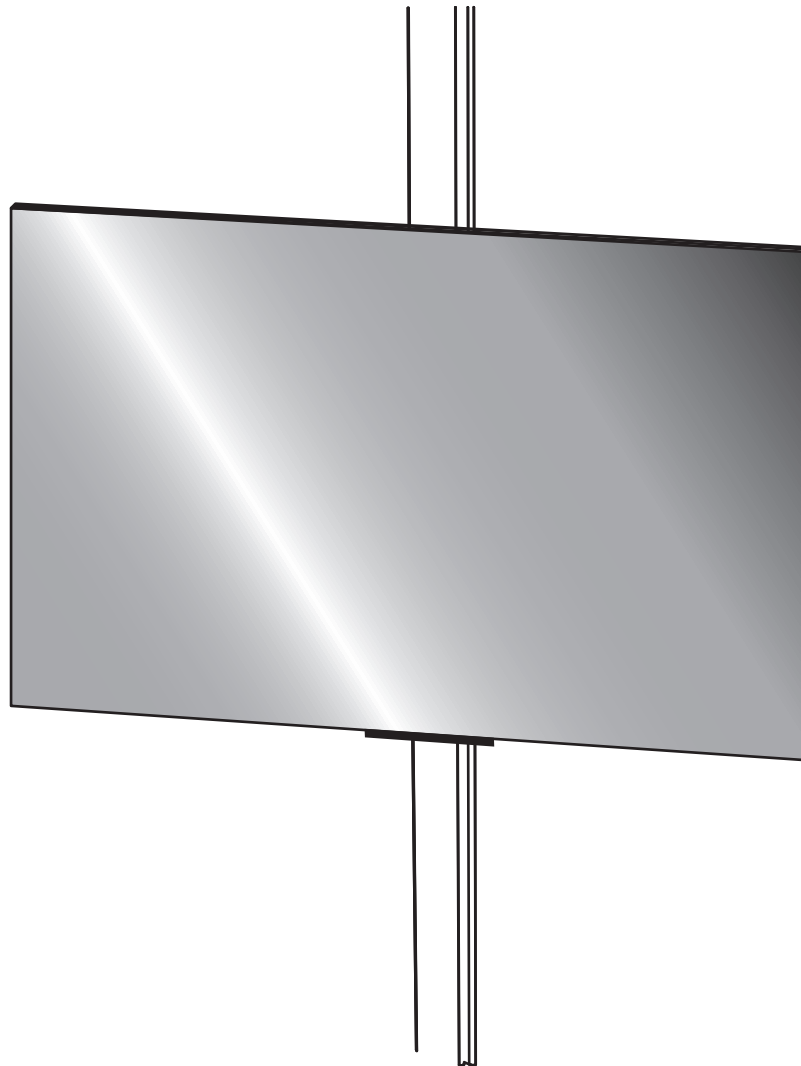

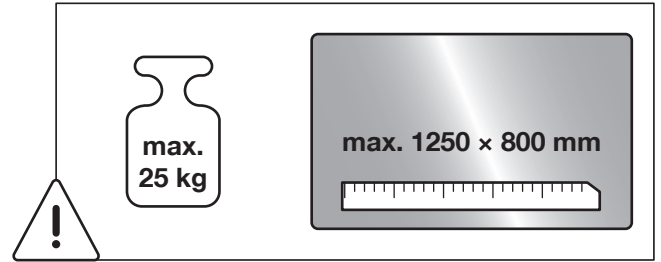
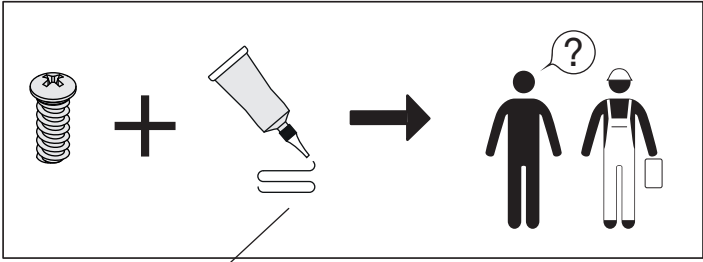

!
Verwendungszweck: Holz
Utilisation : bois
Suitable for use with wood

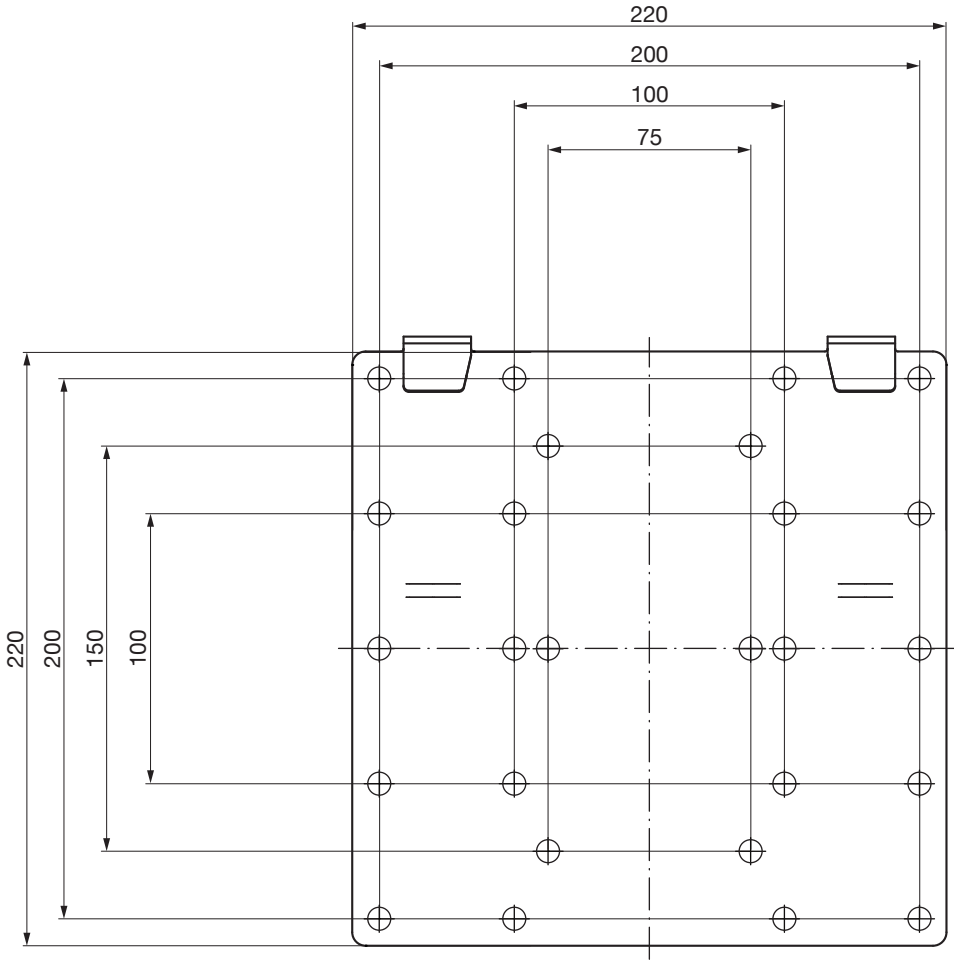

600.0401.xx

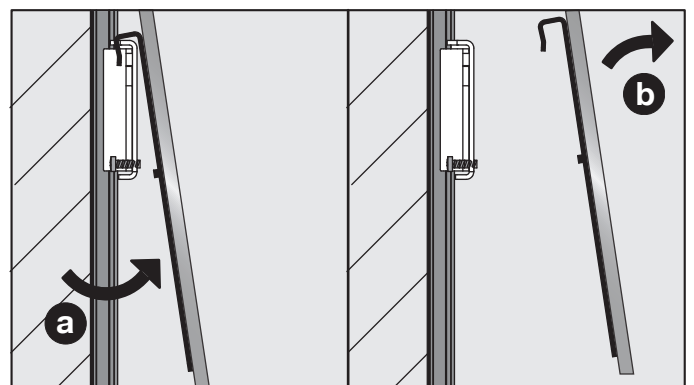
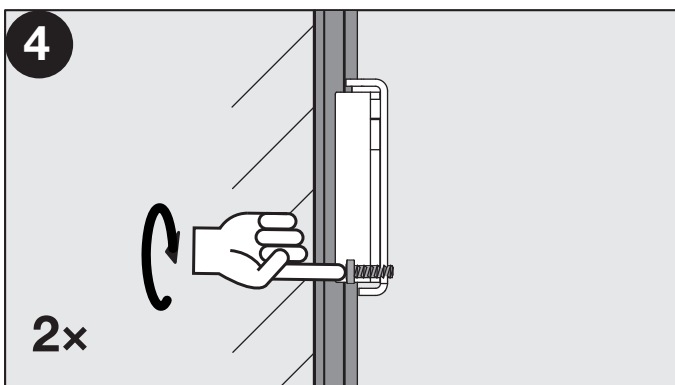
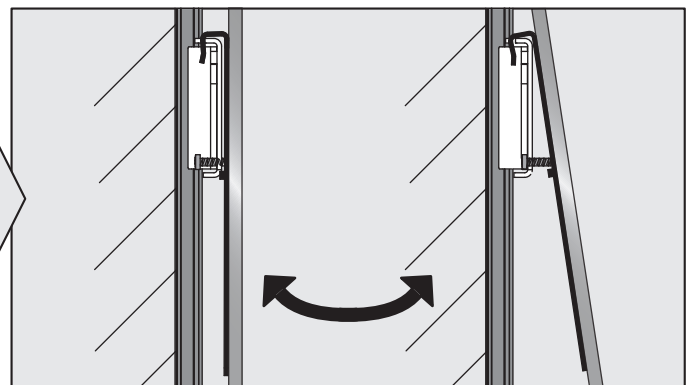
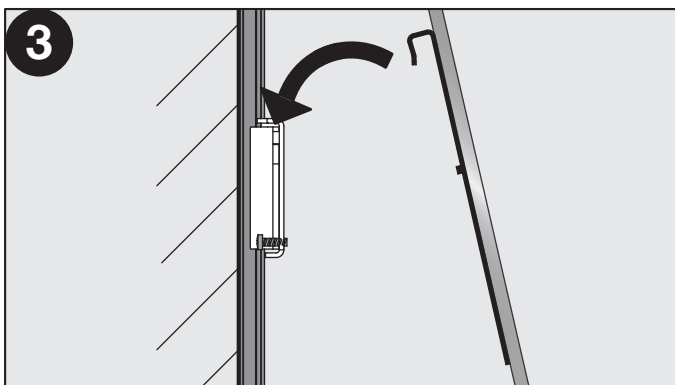
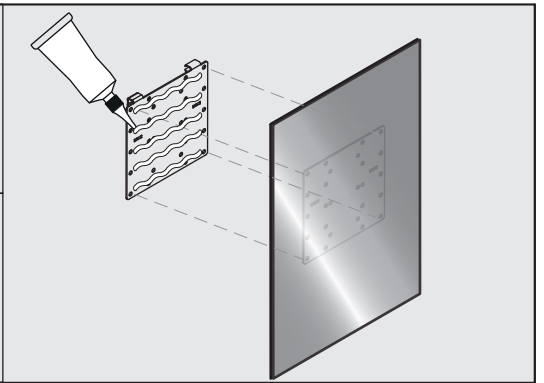
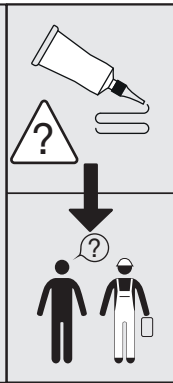
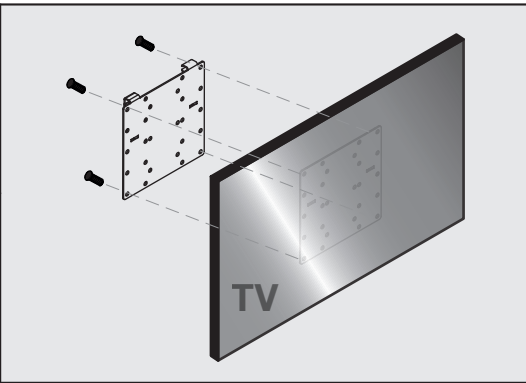
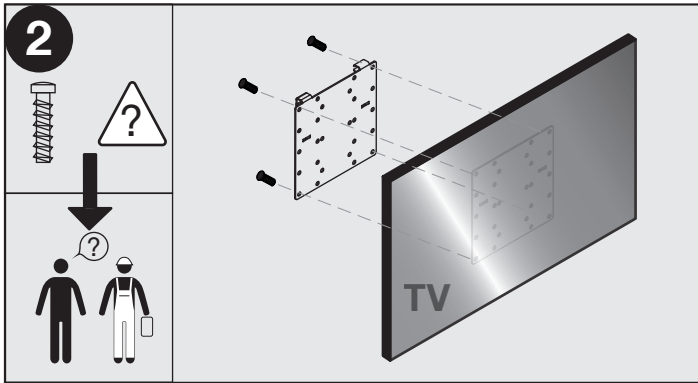
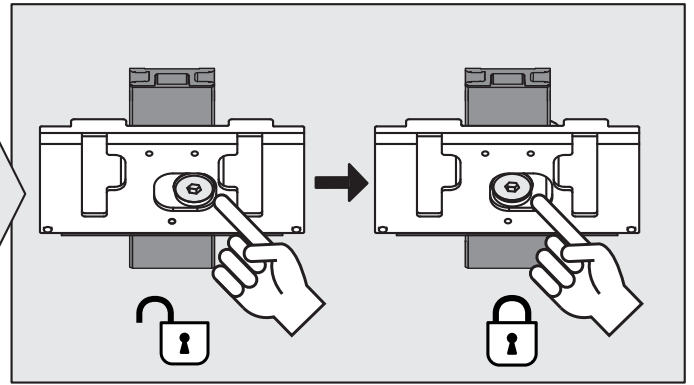
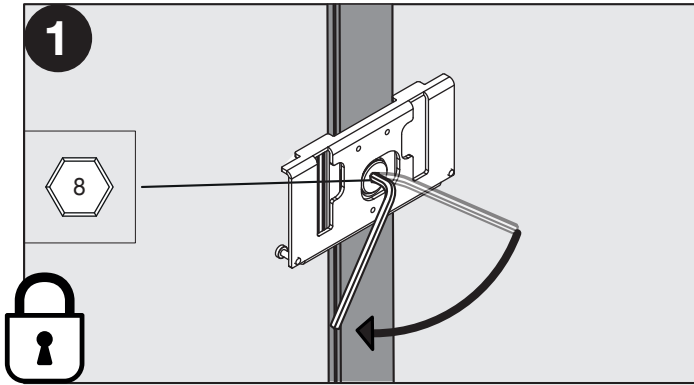
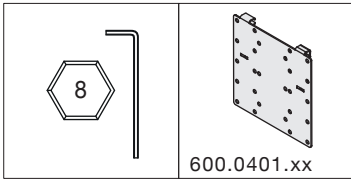

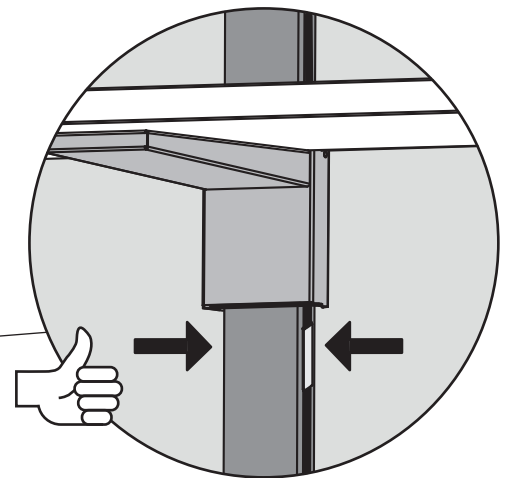
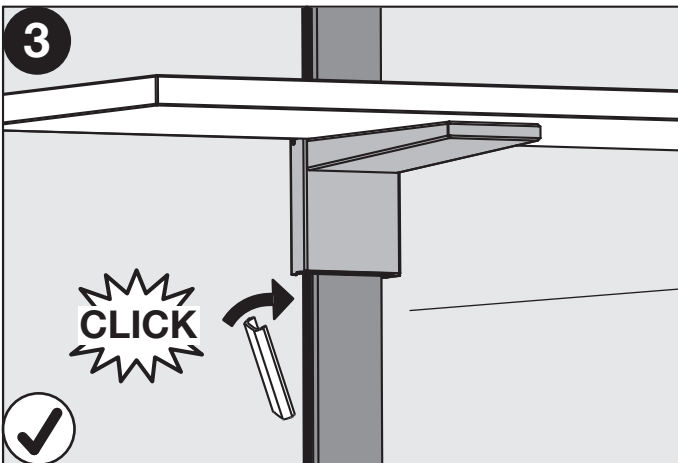
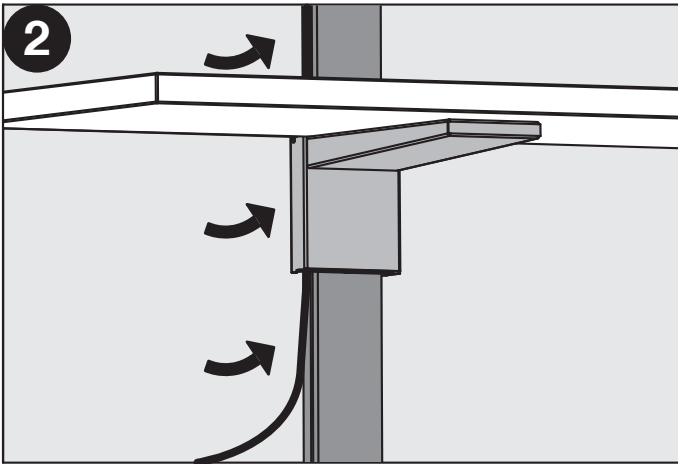
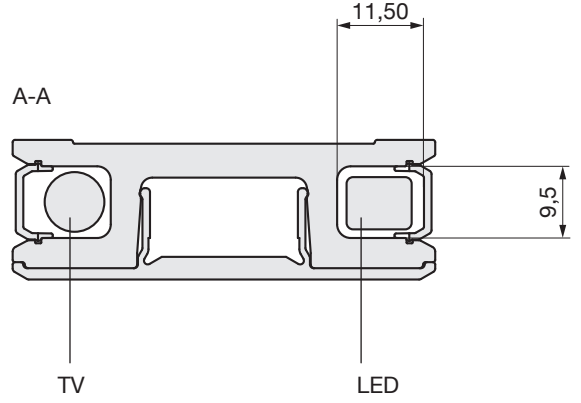
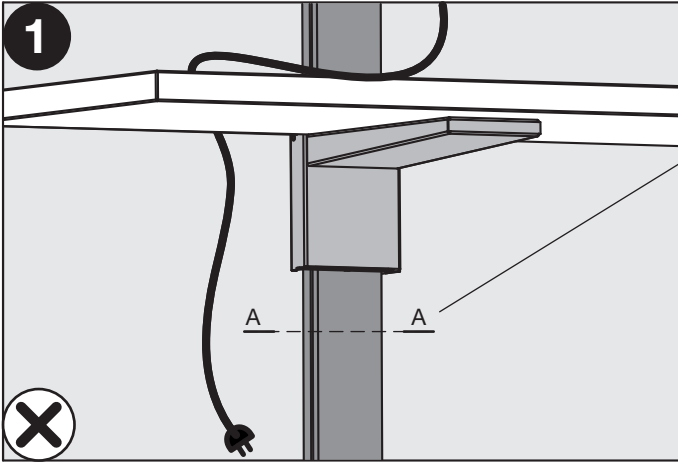
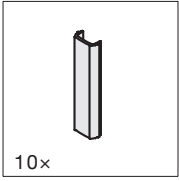

PECASA ZEITSCHRIFTEN- /SCHUHTABLAR

—

Étagère à chaussures / magazines Pecasa
Pecasa magazine/shoe rack

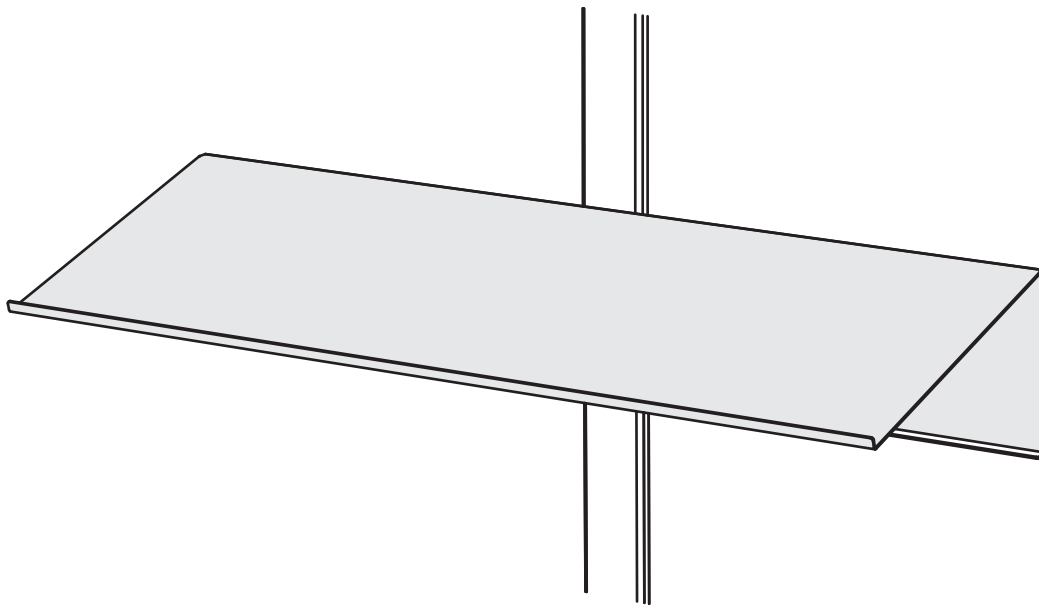

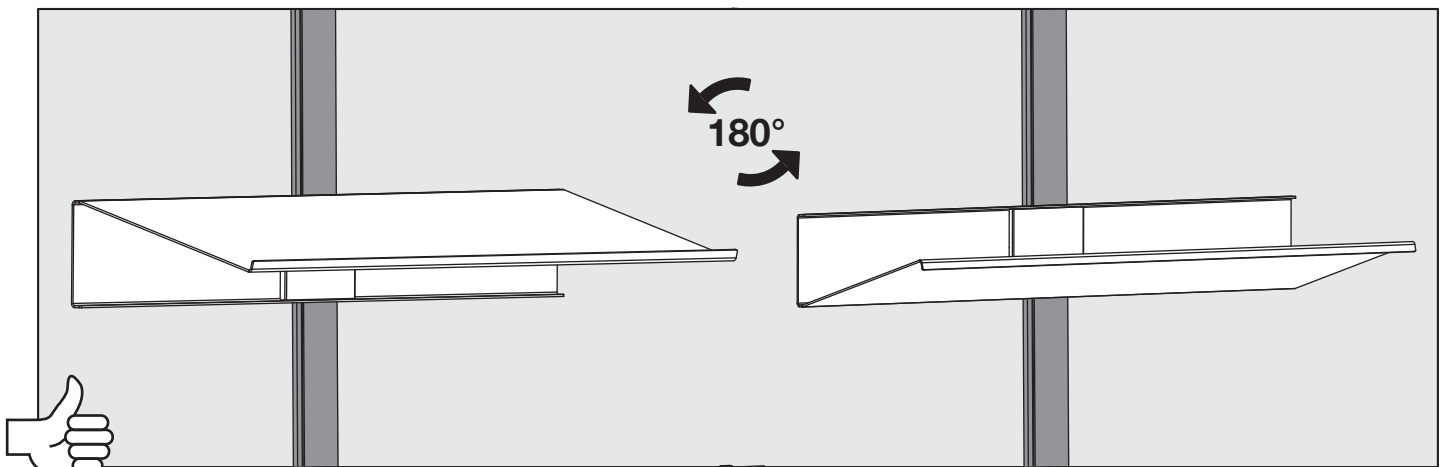
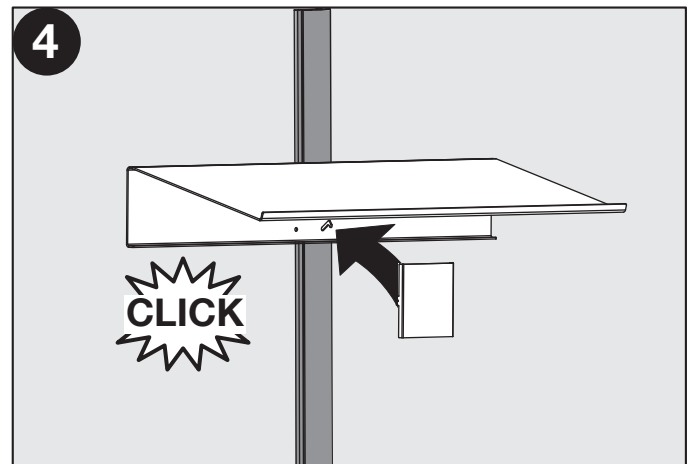
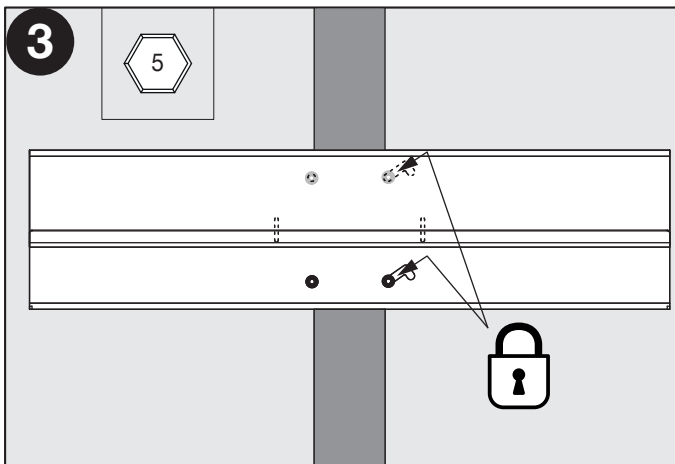
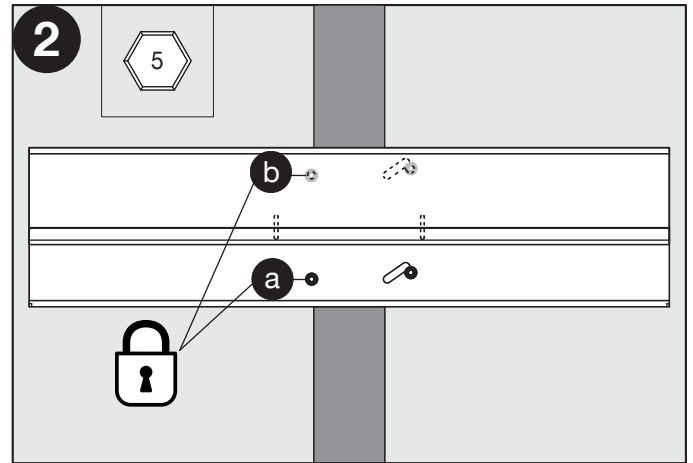
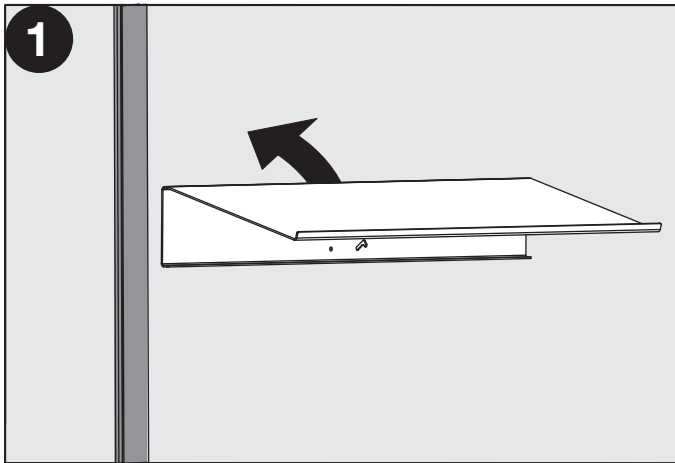
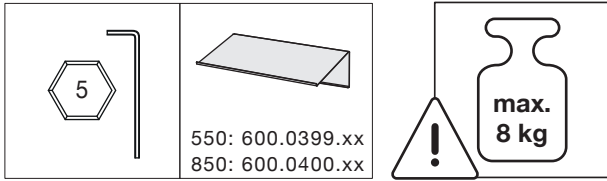

PECASA HAKENLEISTE



Rangée de crochets Pecasa
Pecasa hook rail

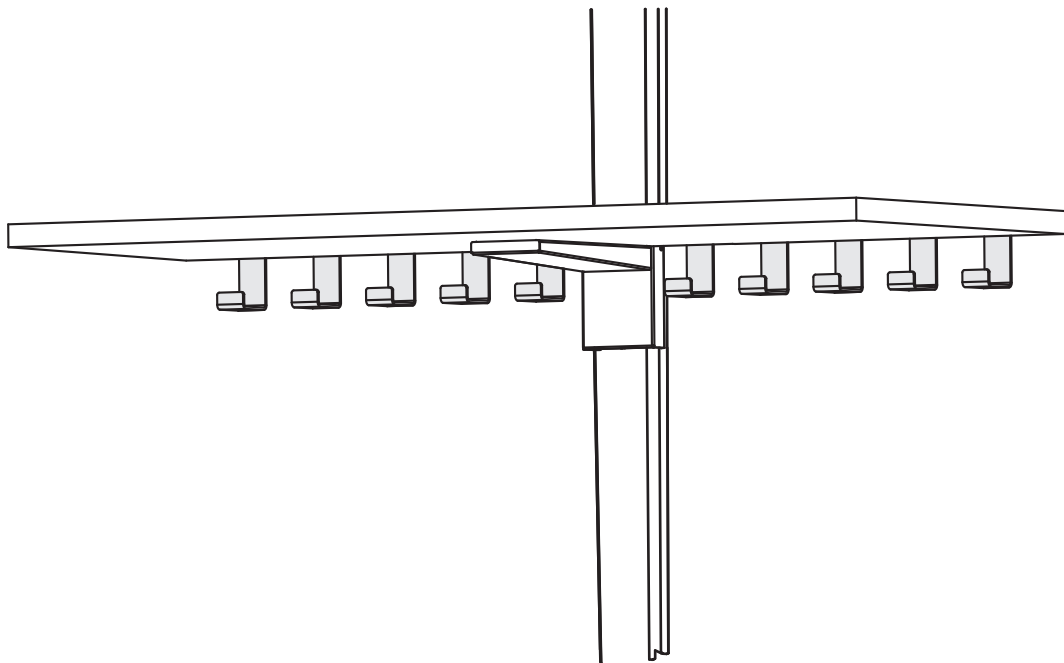

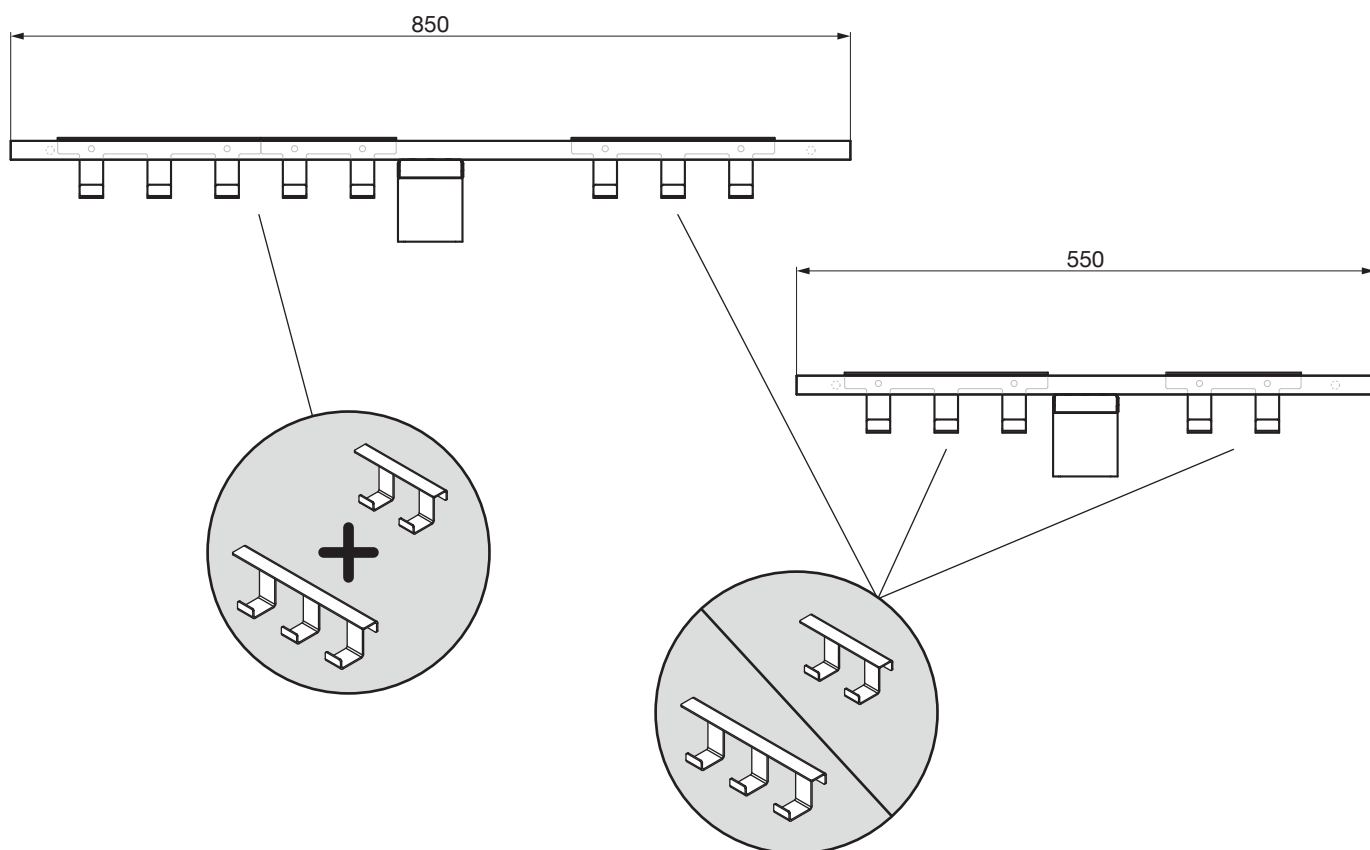
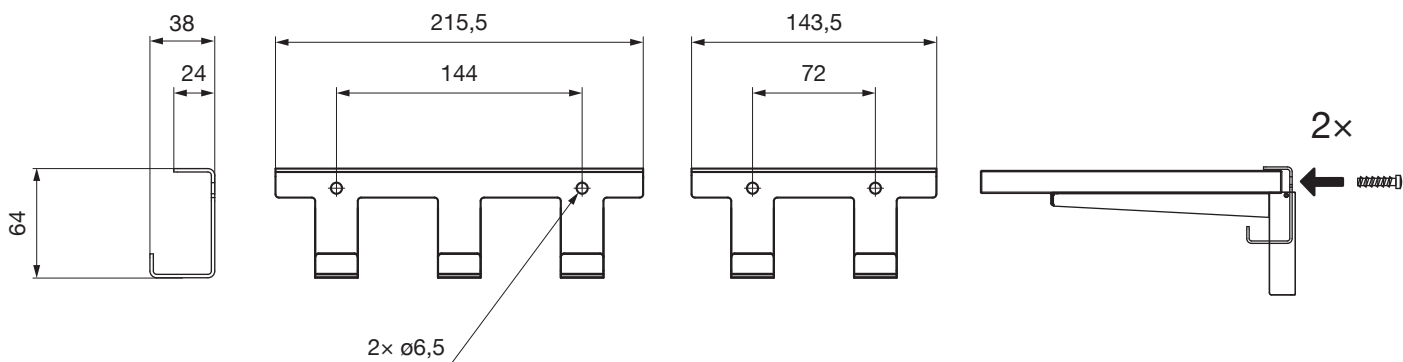
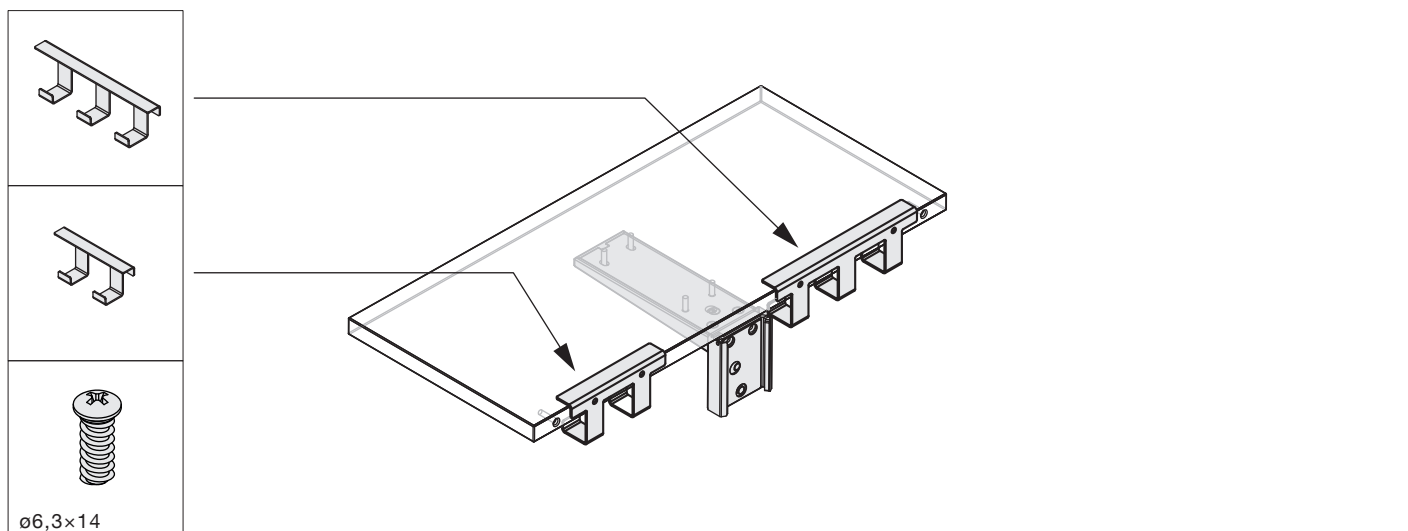

PECASA HOSENHALTER



Porte-pantalons Pecasa
Pecasa trouser rack

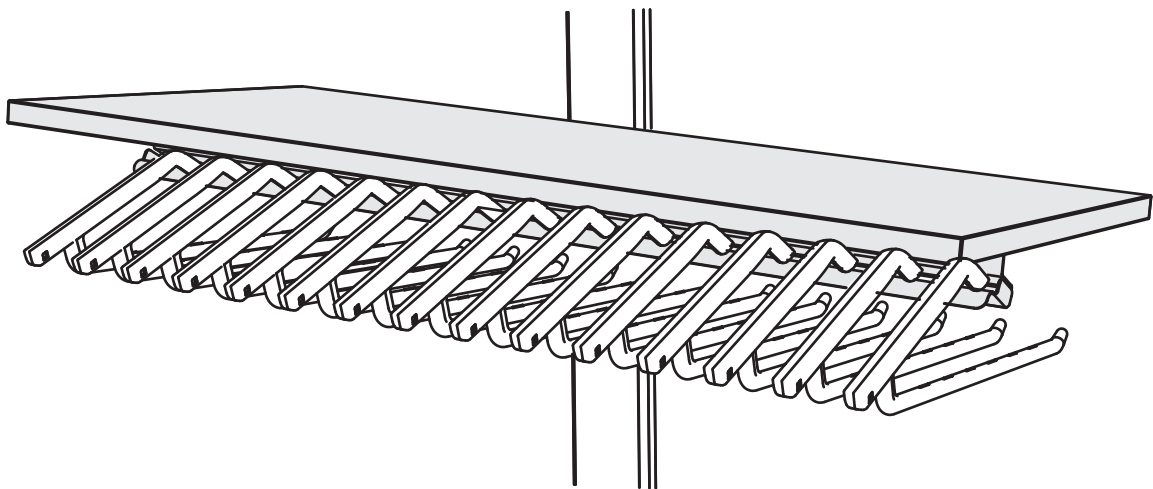

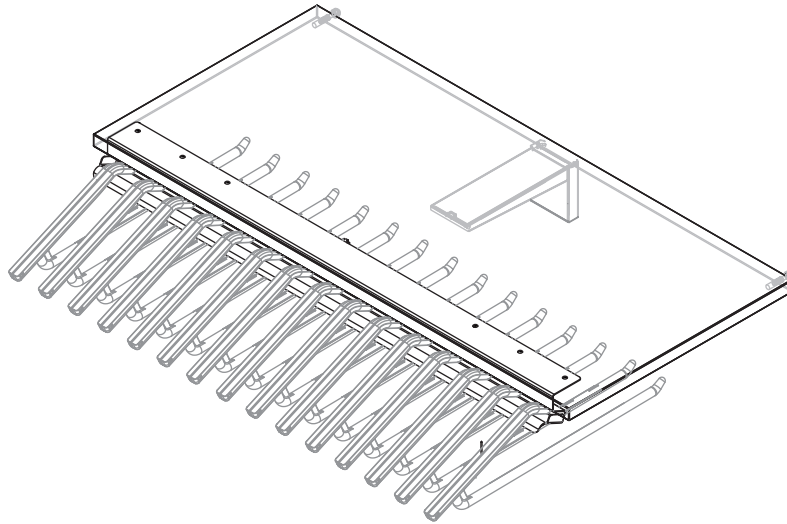
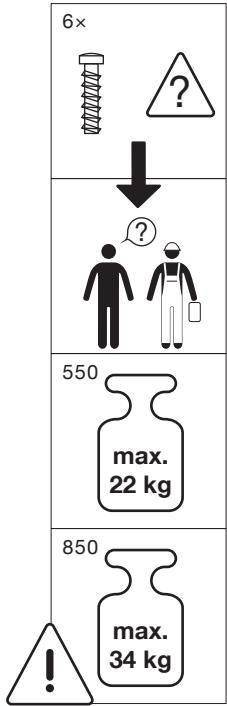

! **Montageanleitung** 950.0727.MA
Instructions de montage 950.0728.MA
Installation instructions

