

Istruzione di montaggio *Assembly Instruction* *Instructions de Montage*

- **Posizionare le guide rispettando le quote indicate ed avvitarle con le apposite viti sui fianchi del mobile.**
Place slides respecting showed data and screw them on the cabinet's sides.
Positionez les glissières en respectant les mesures indiquées et serrez les vis sur les côtés du meuble.

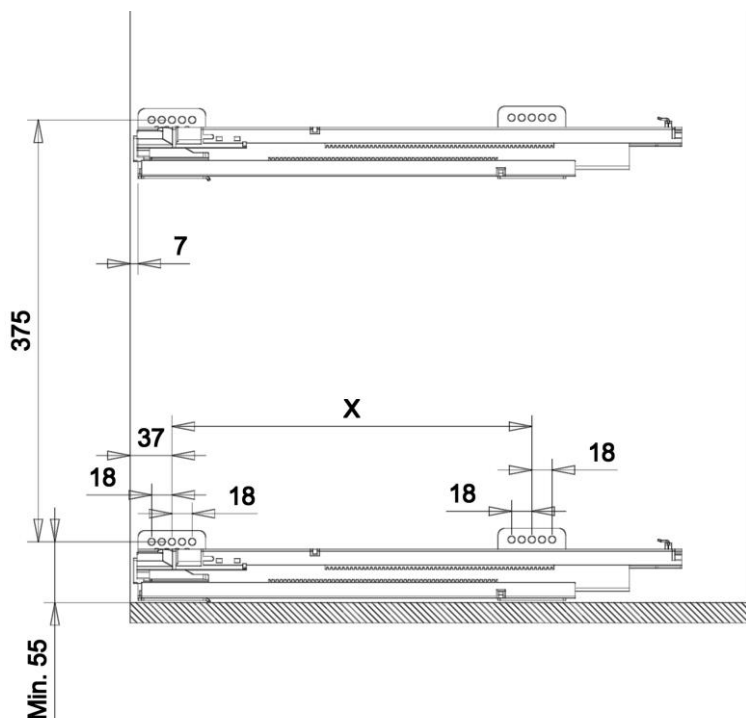

Dimensione Guida Slide Dimension Dimension Glissière	X
300	174 mm
450	288 mm
500	320 mm

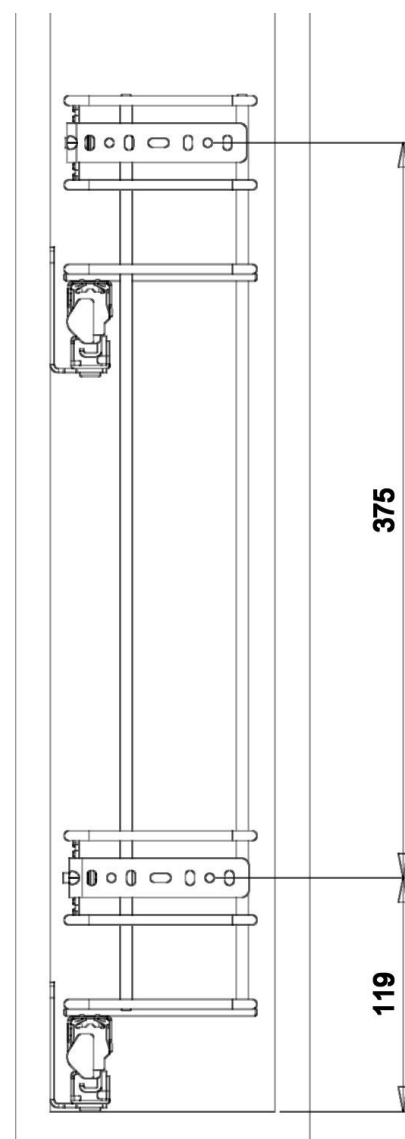

- **Avvitare i piastrini sull'antina rispettando le misure indicate.**
Screw plates on the door respecting showed data.
Vissez les plaques sur la porte en respectant les mesures indiquées.

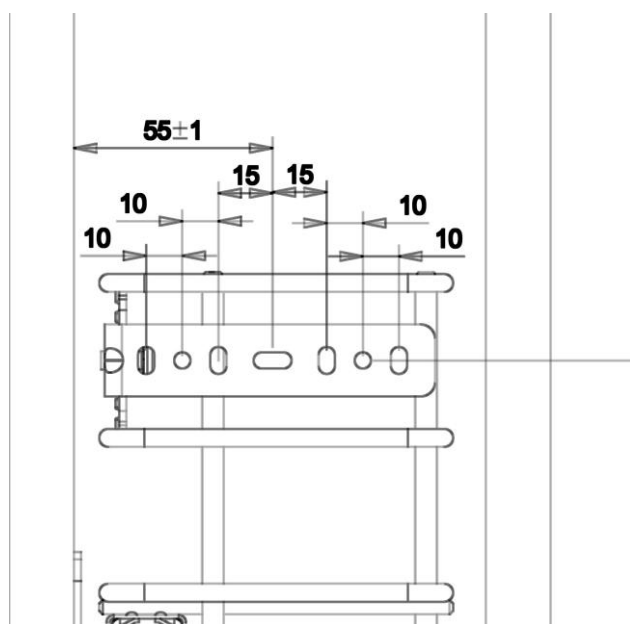

N.B.: Tutte le quote sono espresse in mm ed hanno tolleranza +/- 1 mm.

All data are in mm and the tolerance is +/- 1 mm.

Toutes les dimensions sont en mm et ont une tolérance de +/- 1 mm.

➤ **Montaggio cesto su guide** Basket assembly on the slides Assemblage panier sur glissières

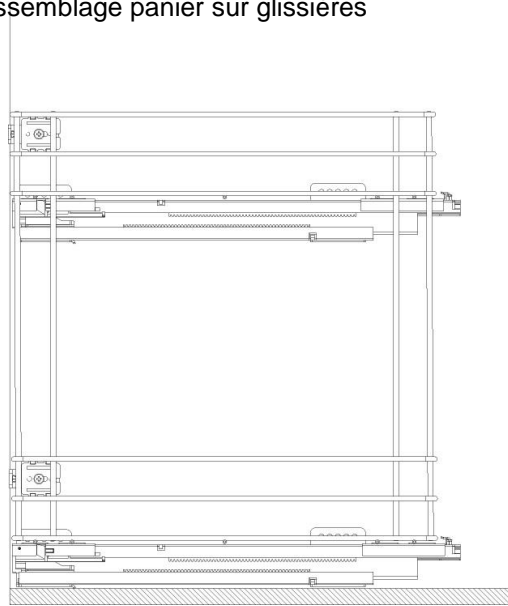
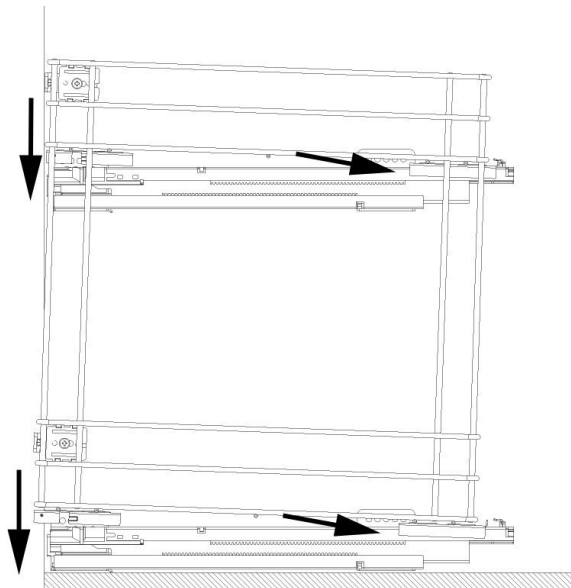

➤ **Una volta montata l'antina effettuare le regolazioni agendo sulle varie viti**

Once assembled the door adjust it by acting on the various screw

Une fois monté la porte, faire des ajustements sur les vis.

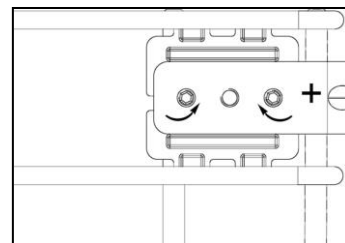
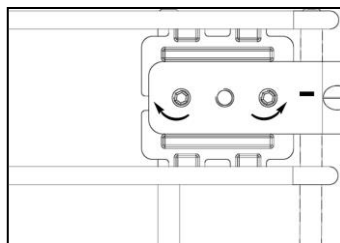
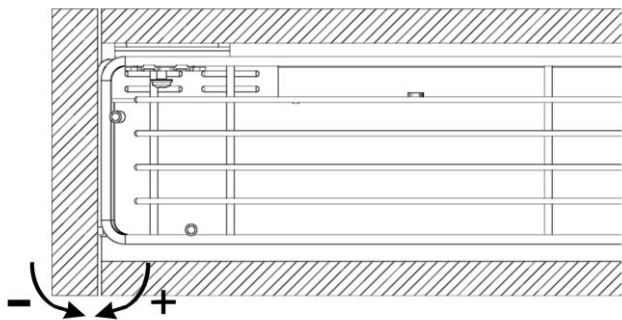
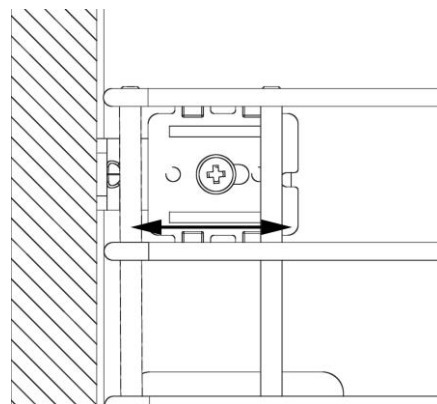
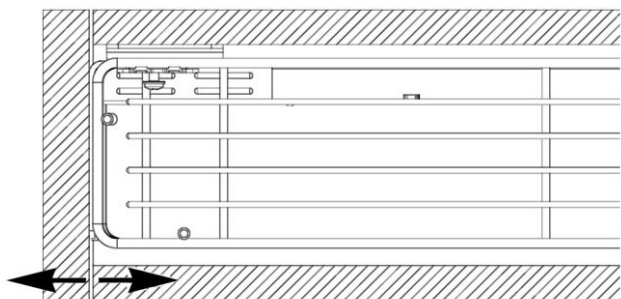

N.B.: Tutte le quote sono espresse in mm ed hanno tolleranza +/- 1 mm.

All data are in mm and the tolerance is +/- 1 mm.

Toutes les dimensions sont en mm et ont une tolérance de +/- 1 mm.