



PRODUCT



DESCRIPTION

- Load capacity: 35kg
- Finish: zink plated
- Length: 250-600mm
- Full extension
- Tool free assembly and removal of drawer
- Silent system guarantees smooth run without noise
- Drawer up&down adjustment: 0~+4mm

SPACE REQUIREMENT

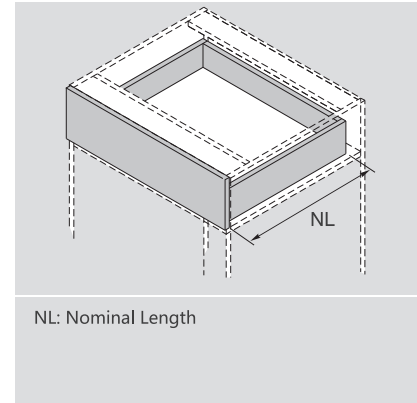

PLANNING

Installation Dimensions(mm)

NL=Nominal Slide Length LT=Internal Cabinet Depth LT=NL+3

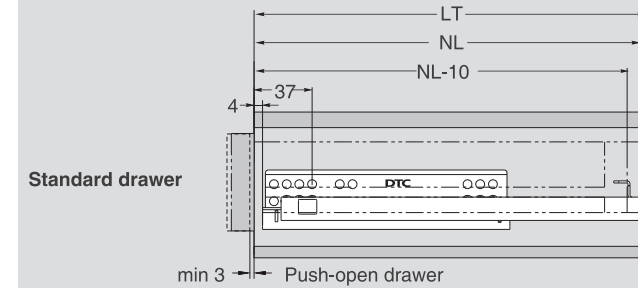

NL=Nominal Slide Length LT=Internal Cabinet Depth LT=NL+21

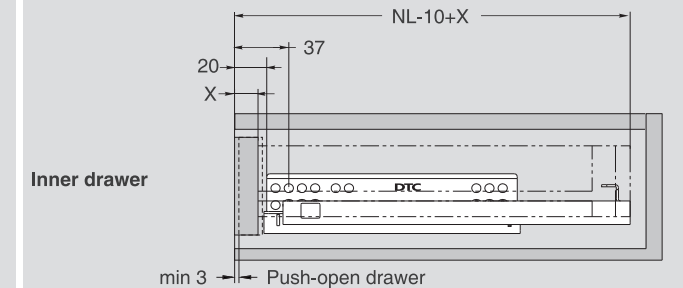

SOFT CLOSE DRAWER / PUSH-OPEN DRAWER

1 Slides (left/right)			
Pre-zinc Steel (F02)			
NL	Soft Close item No.	Push-open item No.	Set/ctn
250mm	SS10C250H1	FF10C250H	10
270mm	SS10C270H1	FF10C270H	10
300mm	SS10C300H1	FF10C300H	10
350mm	SS10C350H1	FF10C350H	10
400mm	SS10C400H1	FF10C400H	10
450mm	SS10C450H1	FF10C450H	10
500mm	SS10C500H1	FF10C500H	10
550mm	SS10C550H1	FF10C550H	10
600mm	SS10C600H1	FF10C600H	10

2 Locking Pin	
Grey(H11)	Item No. SJS01
3 Rod for Push-open Synchronization /For cutting to size,1100mm.Cutting:Internal cabinet width LW-172	
Silver Grey(E18)	Item No. HT0FH02

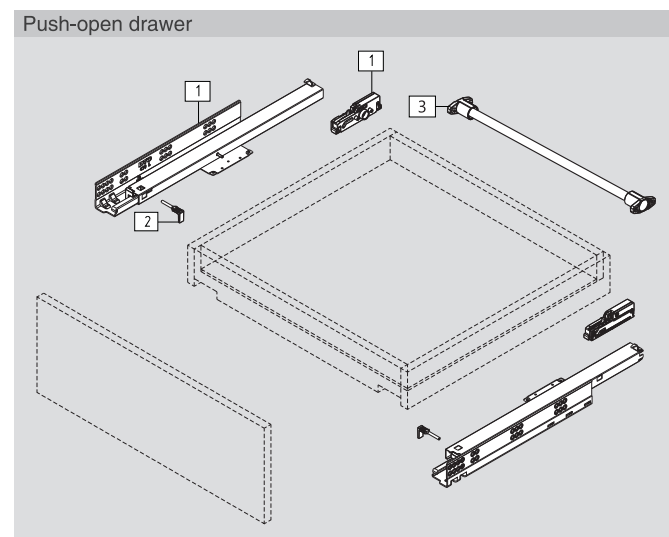
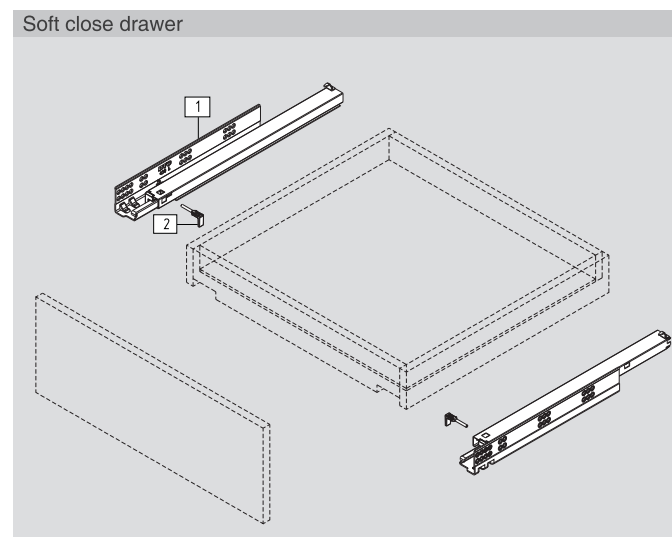

Screw Positions of the Slides(mm)

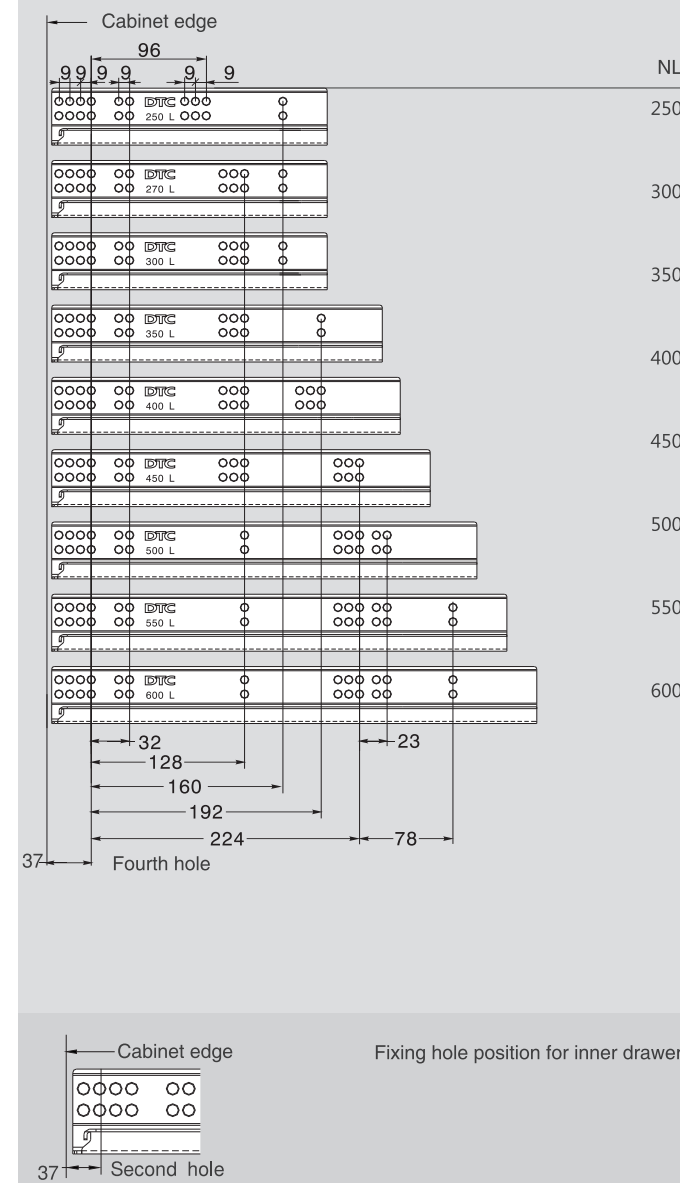

Installation Dimensions(mm)

SKW=Internal Drawer Width
LW=Internal Cabinet Width

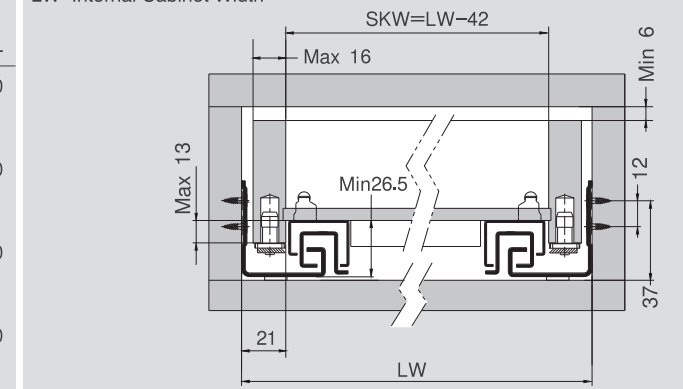

Drawer Back Preparation(mm)

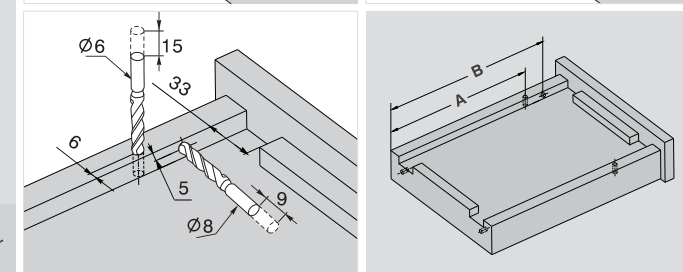
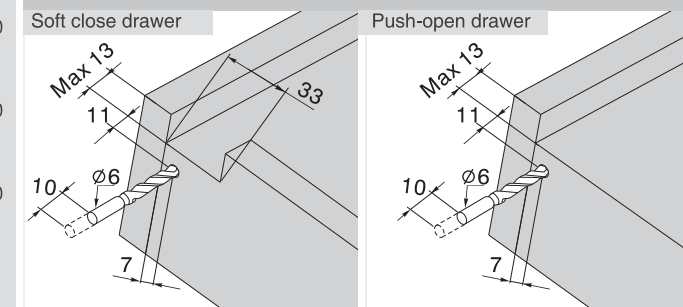

NL (mm)	250	270	300	350	400	450	500	550	600
A (mm)	190	205	245	270	305	330	355	390	415
B (mm)	200.5	215.5	255.5	280.5	319.5	369.5	419.5	469.5	519.5