

PRODUCT DATA SHEET

FREEswing

Up-and-over lift system for wall cabinets

- Multi-Position-Stop & stepless force adjustment
- ClickFixx und 3D-front adjustment
- Positioning pins
- Premounted screws



Cabinet type		WALL UNIT / HIGHBOARD / LIFTER	
Fitting type		Flap fitting	
Application area		FREEswing	
(Carcase dimensions in mm)	Front panel width	Up to 1800	
	Front panel height	370 to 800	
	Front panel weight	Height-dependent	1.9 to 17 kg
	Front panel thickness	Max.	No restrictions
Installation dimensions			
(Carcase dimensions in mm)	Required height	Carcase to ceiling	180
	Clear depth		273
	Clear height		320
	Centre shelf recess		25
Movement system			
	Drive/power pack	Coiled compression spring variants	9
	Lever arms	Variants	1
Design variants			
	Colours/finishes	Cover	Grey or white
		In planning	Other finishes
		Fitting arm	Nickel-plated
Assembly/adjustment			
(in mm)	ClickFixx	Front panel connectors	x
		Torsion bar	x
	Drilling pattern	System 32 for carcase	x
		System 32 for front panel	x
	Force adjustment	Nonius	x
	3D adjustment	Height	+/- 1.5
		Width	+/- 1.5
		Tilt	+/- 1.5
	With positioning pins		x
	With premounted screws	Euro	x
Comfort features			
	SoftSTOPP		x
	Multi-Position-STOPP		x
	eTouch		3rd quarter 2014
Weight			
(in kg)	Fitting	Incl. front panel connectors	1.28
Materials			
	Fitting	Steel	x
	Cover	Plastic	x

PRODUCT DATA SHEET

FREEswing

Accessories		
Adapter for 20x20 aluminium frame		X
Push-to-open		-
Packaging units		
Single	1	X
Multiple	5	-
	10	X
Returnable		In preparation
Quality certificate		
LGA		In planning
Dates		
Product release		Summer 2014

Variable fitting dimensions:

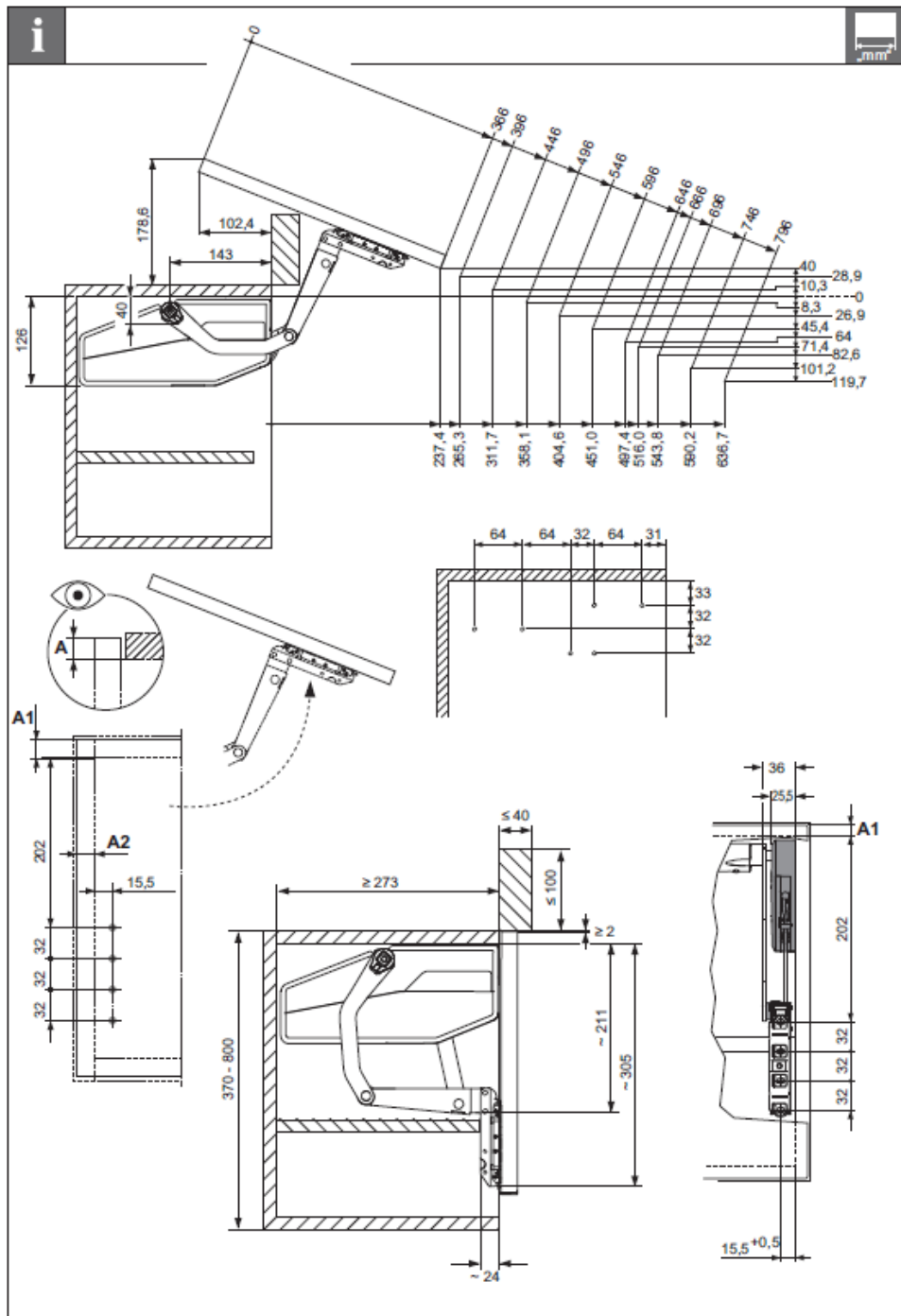

Carcass drilling pattern:

Front panel drilling pattern: