

Slider S10



Slider S10 is a coplanar system for kitchen cabinets and small wall cabinets with doors weighing up to 10 kg. Equipped with carriages with double horizontal rollers and connection-free runners that guarantee smoother and quieter movement than ever before. **S10** is flexible: the Flex version can be adapted to any width of cabinet by simply cutting the profiles to measure.

Due to its features, **S10** is ideal for small units used in the kitchen and bathroom or for larger furniture intended for the living room, bedroom and offices.





Technical information

Coplanar two-door cushioned sliding system.
Capacity 10 kg per door.

Individual door properties:

- max. weight per door 10 kg (evenly distributed)
- width:
 - min. 450 mm
 - max. 1200 mm
- height:
 - max. 800 mm
- thickness:
 - min. 16 mm
 - max. 30 mm
 - max. with handle 40 mm
- height from the ground:
 - 35 mm (kitchen cabinet)
- material:
 - a) wood or derived material
 - b) glass with metal frame

Door adjustment:

- vertical adjustment ± 5 mm
- horizontal adjustment ± 2.5 mm

Door front adjustment:

- wall cabinet
 - upper ± 2 mm
 - lower $\pm 2,5$ mm
- kitchen cabinet
 - upper $\pm 2,5$ mm
 - lower ± 2 mm

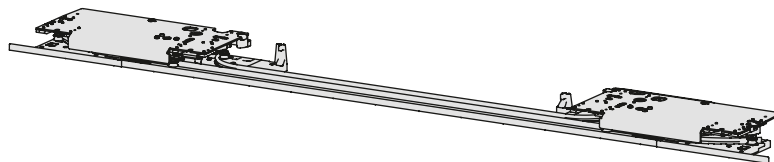

Wall cabinet

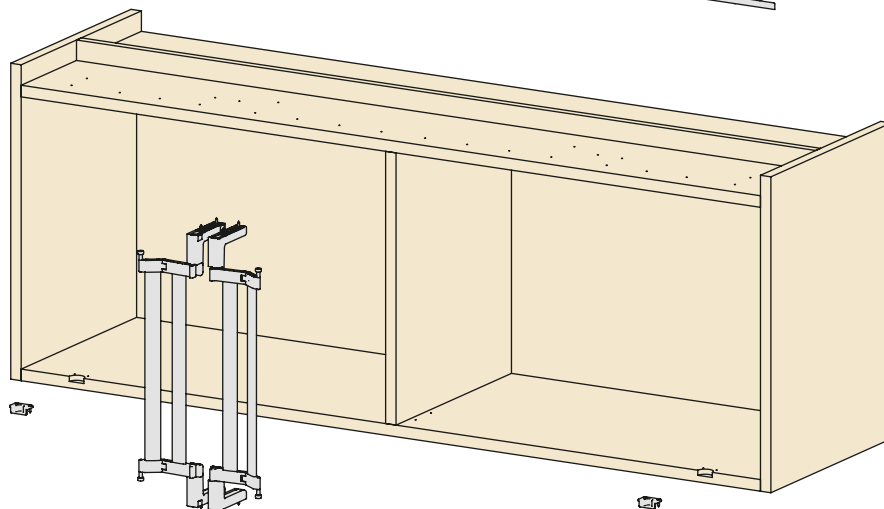

Kitchen cabinet

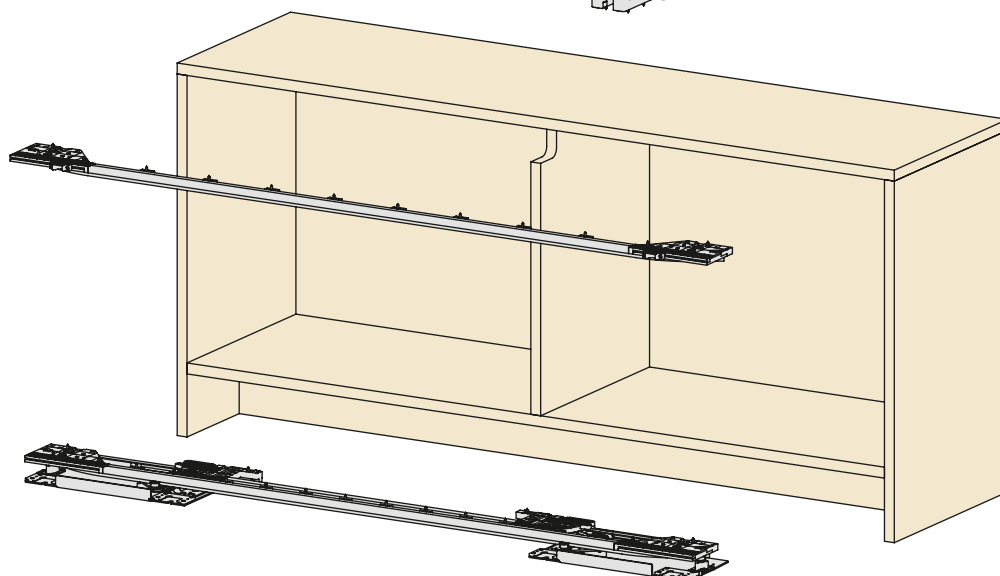

Key feature





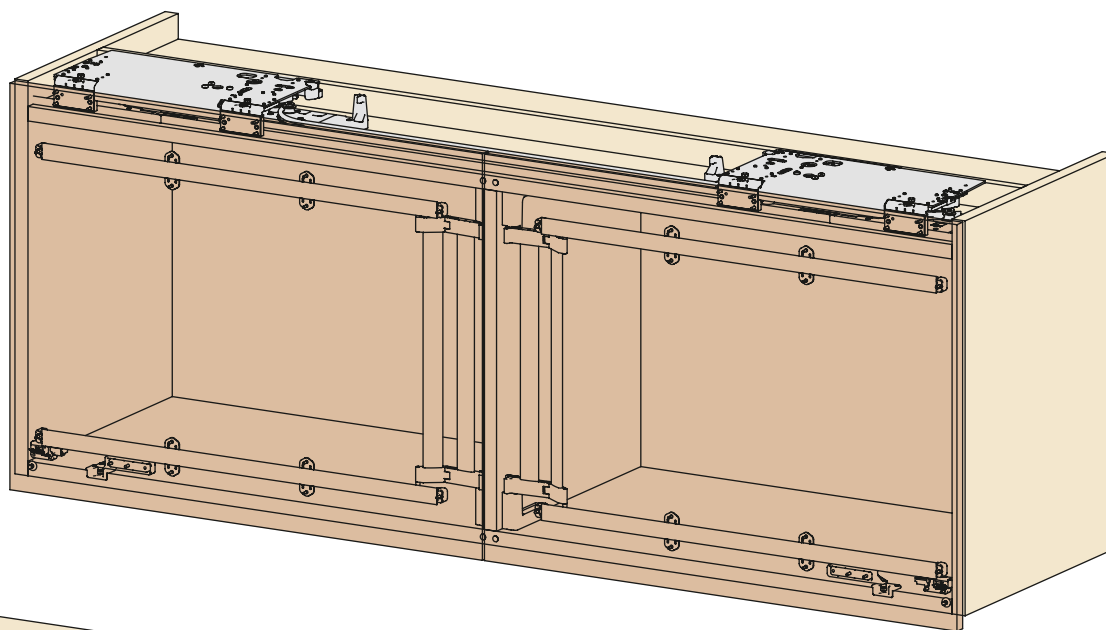



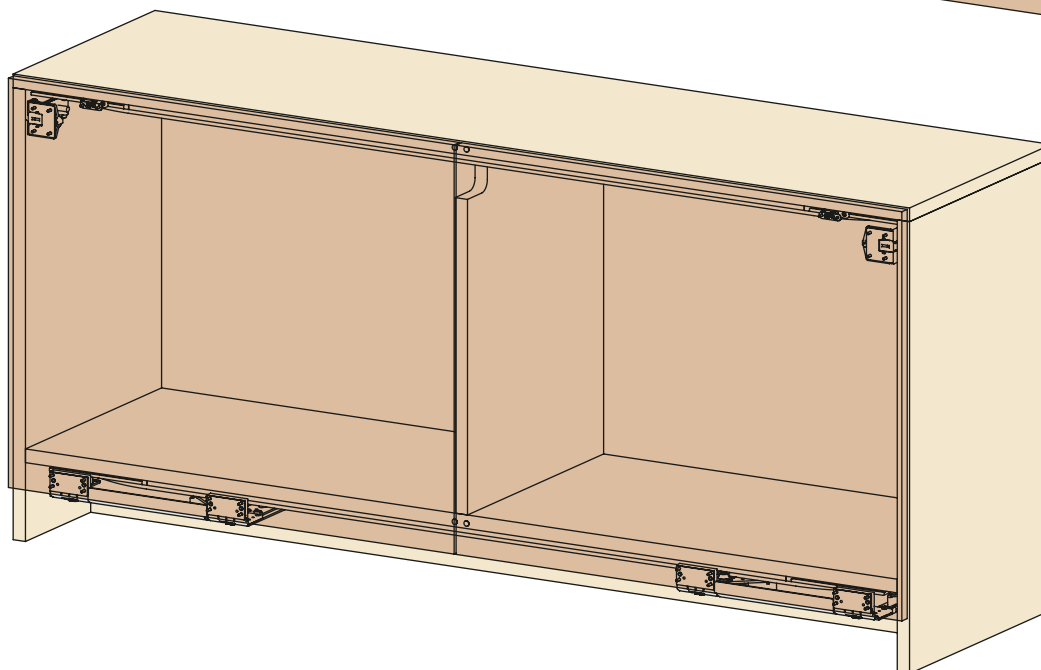

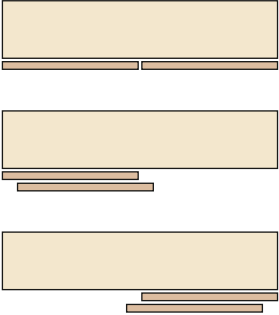
- Extremely easy to customise and assemble.
- Secured with screws without the need of drilling or machining the doors and unit.
- Single-piece sliding track.
- Innovative suspended slider with double horizontal wheels.
- Assisted opening and closing.
- Front adjustment of the doors.
- Wall unit with innovative door runner system.
- Extreme strength and durability, stress-tested with 100,000 cycles.

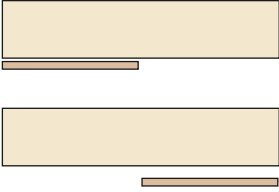
Wall cabinet

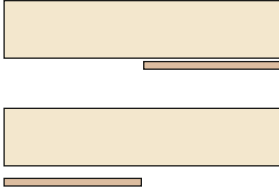

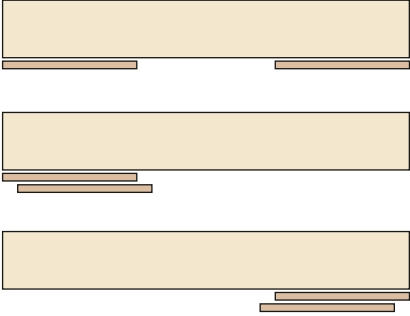
Kitchen cabinet

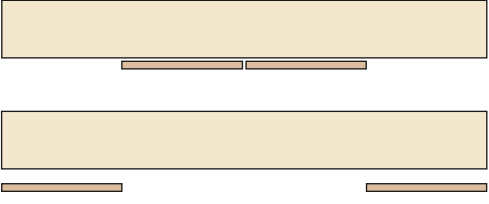

<p>Standard</p>		<p>Slider S10 Slider S20</p>	 <p>Slider S20</p>
<p>One</p>		<p>Slider S10 Slider S20</p>	 <p>Slider S20</p>
<p>One</p>		<p>Slider S10 Slider S20</p>	 <p>Slider S20</p>
<p>Step</p>		<p>Slider S20</p>	 <p>Slider S20</p>
<p>Reverso</p>		<p>Slider S20</p>	 <p>Slider S20</p>