

Slider S10

**Sistema di scorrimento
complanare a due ante
ammortizzato per madie**
- portata 10 kg.

**Coplanar two-door
cushioned sliding system
for kitchen cabinets**
- capacity 10 kg per door.

**Système coulissant
coplanaire amorti à deux portes
pour meubles bas**
- portée 10 kg.

**Flächenbündiges, gedämpftes
GLEITSYSTEM mit zwei Türen
für Unterschränke**
- Tragfähigkeit 10 kg.

**Sistema de deslizamiento
coplanario de dos puertas
amortiguado para aparadores**
- capacidad 10 kg.

Montaggio
e regolazione
Standard

Assembly and
adjustments
Standard

Montage
et réglage
Standard

Montage und
Regulierung
Standardausführung

Montaje
y regulación
Estándar

SALICE

[ITA] INDICE

Caratteristiche tecniche	3
Contenuto imballi	4
Tipologia di montaggio	7
Lavorazioni sulla struttura	8
Lavorazioni sull'anta	9
Taglio dei profili superiori	10
Montaggio del meccanismo superiore	11
Taglio dei profili inferiori	15
Montaggio del meccanismo inferiore	16
Montaggio del meccanismo inferiore sulla struttura	25
Montaggio del meccanismo superiore sulla struttura	27
Preparazione delle ante	28
Elemento stabilizzatore	29
Messa in bolla del mobile	30
Montaggio delle ante	30
Regolazione delle ante	32
Regolazione dell'elemento di stabilità	36
Regolazione della velocità di chiusura dell'anta	38
Applicazione dei carter ai braccetti superiori	39
Applicazione dei paracolpi	40

[ENG] INDEX

Technical features	3
Packaging Contents	4
Types of assembly	7
Drilling and machining the cabinet	8
Working on the door	9
Cutting the upper profiles	10
Assembling the upper mechanism	11
Cutting the lower profiles	15
Assembling the lower mechanism	16
Installing the lower mechanism onto the cabinet	25
Installing the upper mechanism onto the cabinet	27
Doors preparation	28
Stabiliser element	29
Unit levelling	30
Mounting of the doors	30
Adjusting the doors	32
Adjustment of the stabiliser	36
Adjustment of the closing speed of the door	38
Application of the covers on the top arms	39
Application of bumper	40

[FRA] INDEX

Caractéristiques techniques	3
Contenus des emballages	4
Types de montage	7
Usinage du meuble	8
Plan de perçage de la porte	9
Découpe des profilés hauts	10
Montage du mécanisme haut	11
Découpe des profilés bas	15
Montage du mécanisme bas	16
Montage du mécanisme bas sur la structure	25
Montage du mécanisme haut sur la structure	27
Préparation des portes	28
Stabilisateur	29
Mise à niveau du meuble	30
Montage des portes	30
Réglage des portes	32
Réglage du stabilisateur	36
Réglage de la vitesse de fermeture de la porte	38
Mise en place des caches sur les pattes de fixation hautes	39
Mise en place des butées	40

[DEU] INHALTSVERZEICHNIS

Technische Eigenschaften	3
Verpackungsinhalt	4
Montageart	7
Arbeiten am Korpus	8
Bearbeitung der Tür	9
Zuschneiden der oberen Profile	10
Montage des oberen Mechanismus	11
Zuschnitt der unteren Profile	15
Montage des unteren Mechanismus	16
Montage des unteren Mechanismus am Korpus	25
Montage des oberen Mechanismus am Korpus	27
Vorbereitung der Türen	28
Stabilisierungselement	29
Möbel ausrichten	30
Montage der Türen	30
Einstellungen der Türen	32
Einstellung des Stabilisierungselement	36
Verstellung der Schließgeschwindigkeit der Tür	38
Anbringung der Abdeckungen an den oberen Halterungen	39
Anbringung der Puffer	40

[ESP] ÍNDICE

Características técnicas	3
Relación contenido embalaje	4
Tipos de montaje	7
Trabajos en la estructura	8
Trabajos en la puerta	9
Corte de los perfiles superiores	10
Montaje del mecanismo superior	11
Corte de los perfiles inferiores	15
Montaje del mecanismo inferior	16
Montaje del mecanismo inferior en la estructura	25
Montaje del mecanismo superior en la estructura	27
Preparación de las puertas	28
Elemento estabilizador	29
Nivelación del mueble	30
Montaje de las puertas	30
Ajustes de las puertas	32
Regulación del elemento de estabilidad	36
Regulación de la velocidad de cierre de la puerta	38
Aplicación de los cárteres a los brazos superiores	39
Aplicación de los topes	40

[ITA] CARATTERISTICHE TECNICHE

COMPOSIZIONE MECCANISMO

- › Profili in alluminio: lega 6060T5, anodizzati argento.
- › Ruote di scorrimento: cuscinetti per alta velocità.
- › Componenti: pressofusi in zama primaria 15, laminati in acciaio, elementi in plastica.

CARATTERISTICHE ANTE

- › Peso massimo per singola anta 10 kg (uniformemente distribuito).
- › Larghezza: - minimo 450 mm;
- massimo 1200 mm.
- › Altezza: - massimo 800 mm.
- › Spessore: - minimo 16 mm;
- massimo 30 mm,
- 40 mm con maniglia.
- › Altezza da terra: - 35 mm.
- › Materiale: a) legno o derivati;
b) telaio in metallo e vetro.
- › Regolazione dell'anta:
- verticale $\pm 5,0$ mm;
- orizzontale $\pm 2,5$ mm.
- › Regolazione frontale dell'anta:
- superiore $\pm 2,0$ mm;
- inferiore $\pm 2,5$ mm.

TIPOLOGIE APERTURE

- › S10 può essere impiegato con due ante di uguali dimensioni oppure una sola anta su vano a giorno o cassetti.
- › L'apertura delle ante è prevista tramite l'ausilio di maniglie posizionate al centro del mobile.

[ENG] TECHNICAL FEATURES

FEATURES OF THE MECHANISM

- › Aluminium profiles: 6060T5 alloy, silver anodised.
- › Rollers: high-velocity bearings.
- › Components: in primary zamak 15, coated steel, plastic.

DOOR FEATURES

- › Maximum weight for each door 10 kg (evenly distributed).
- › Width: - minimum 450 mm;
- maximum 1200 mm.
- › Height: - maximum 800 mm.
- › Thickness: - minimum 16 mm;
- maximum 30 mm,
- 40 mm with handle.
- › Height from the ground: - 35 mm.
- › Material: a) wood or derived material;
b) glass with metal frame.
- › Door adjustment:
- vertical ± 5.0 mm;
- horizontal ± 2.5 mm.
- › Door front adjustment:
- upper ± 2.0 mm;
- lower ± 2.5 mm.

TYPES OF OPENING

- › S10 can be used with two doors of equal size or a single door for an open storage compartment or drawers.
- › The doors are opened by means of handles fitted at the centre of the unit.

[DEU] TECHNISCHE EIGENSCHAFTEN

ZUSAMMENSETZUNG DES MECHANISMUS

- › Profile aus Aluminium: Legierung 6060T5, eloxiert, silber.
- › Laufräder: Hochgeschwindigkeit-Lager.
- › Bauteile: 15-Zamakdruckguss, Stahlblech, Kunststoff.

EIGENSCHAFTEN DER TÜREN

- › Maximales Gewicht pro Tür 10 kg (gleichmäßig verteilt).
- › Breite: - min. 450 mm;
- max. 1200 mm.
- › Höhe: - max. 800 mm.
- › Stärke: - min. 16 mm;
- max. 30 mm,
- 40 mm incl. Griff.
- › Höhe ab dem Boden: - 35 mm.
- › Material: a) Holz oder Holzprodukte;
b) Rahmen aus Metall oder Glas.
- › Regulierung der Tür:
- vertikal $\pm 5,0$ mm;
- horizontal $\pm 2,5$ mm.
- › Front-Regulierung der Tür:
- oben $\pm 2,0$ mm;
- unten $\pm 2,5$ mm.

ÖFFNUNGSTYPEN

- › S10 kann für 2 Türen mit gleichen Abmessungen oder für eine einseitige Tür und z. Bsp. Schubladen verwendet werden.
- › Die Öffnung der Türen ist mithilfe von Griffen, die sich in der Mitte des Möbelstücks befinden, vorgesehen.

[FRA] CARACTÉRISTIQUES TECHNIQUES

COMPOSITION DU MÉCANISME

- › Profilés en aluminium : alliage 6060T5 anodisés argent.
- › Roulettes de coulissement : roulements pour grande vitesse.
- › Composants : zamak 15 primaire, acier laminé, éléments en plastique.

CARACTÉRISTIQUES DES PORTES

- › Poids maximum par porte 10 kg (réparti de manière uniforme).
- › Largeur : - minimale 450 mm ;
- maximale 1200 mm.
- › Hauteur : - maximale 800 mm.
- › Épaisseur : - minimale 16 mm ;
- maximale 30 mm,
- 40 mm avec la poignée.
- › Hauteur du sol : - 35 mm.
- › Matériau : a) bois ou produits dérivés ;
b) cadre en métal ou en verre.
- › Réglage de la porte :
- vertical $\pm 5,0$ mm ;
- horizontal $\pm 2,5$ mm.
- › Réglage avant de la porte :
- supérieur $\pm 2,0$ mm ;
- inférieur $\pm 2,5$ mm.

TYPES D'OUVERTURES

- › S10 peut être utilisé avec deux portes de même taille ou une seule porte pour un espace de rangement ouvert ou des tiroirs.
- › L'ouverture des portes est prévue grâce à des poignées placées au centre du meuble.

[ESP] CARACTERÍSTICAS TÉCNICAS

COMPOSICIÓN DEL MECANISMO

- › Perfiles de aluminio: aleación 6060T5, anodizados en plata.
- › Ruedas de deslizamiento: cojinetes para alta velocidad.
- › Componentes: aleaciones primarias de zinc y aluminio 15, laminados de acero, elementos de plástico.

CARACTERÍSTICAS DE LAS PUERTAS

- › Peso máximo para cada puerta 10 kg (uniformemente distribuido).
- › Anchura: - mínimo 450 mm;
- máximo 1200 mm.
- › Altura: - máximo 800 mm.
- › Espesor: - mínimo 16 mm;
- máximo 30 mm,
- 40 mm con manilla.
- › Altura desde el suelo: - 33 mm.
- › Material: a) madera o derivados;
b) bastidor de metal y vidrio.
- › Regulación de la puerta:
- vertical $\pm 5,0$ mm;
- horizontal $\pm 2,5$ mm.
- › Regulación frontal de la puerta:
- superior $\pm 2,0$ mm;
- inferior $\pm 2,5$ mm.

TIPOLOGÍAS DE APERTURAS

- › S10 se puede utilizar con dos puertas de las mismas dimensiones o con una sola puerta para compartimentos a la vista o cajones.
- › La apertura de las puertas se realiza mediante la ayuda de manillas colocadas en el centro del mueble.

Slider S10

[ITA] CONTENUTO IMBALLI

[ENG] PACKAGING CONTENTS

[FRA] CONTENUS DES EMBALLAGES

[DEU] VERPACKUNGSIHALT

[ESP] RELACIÓN CONTENIDO EMBALAJE

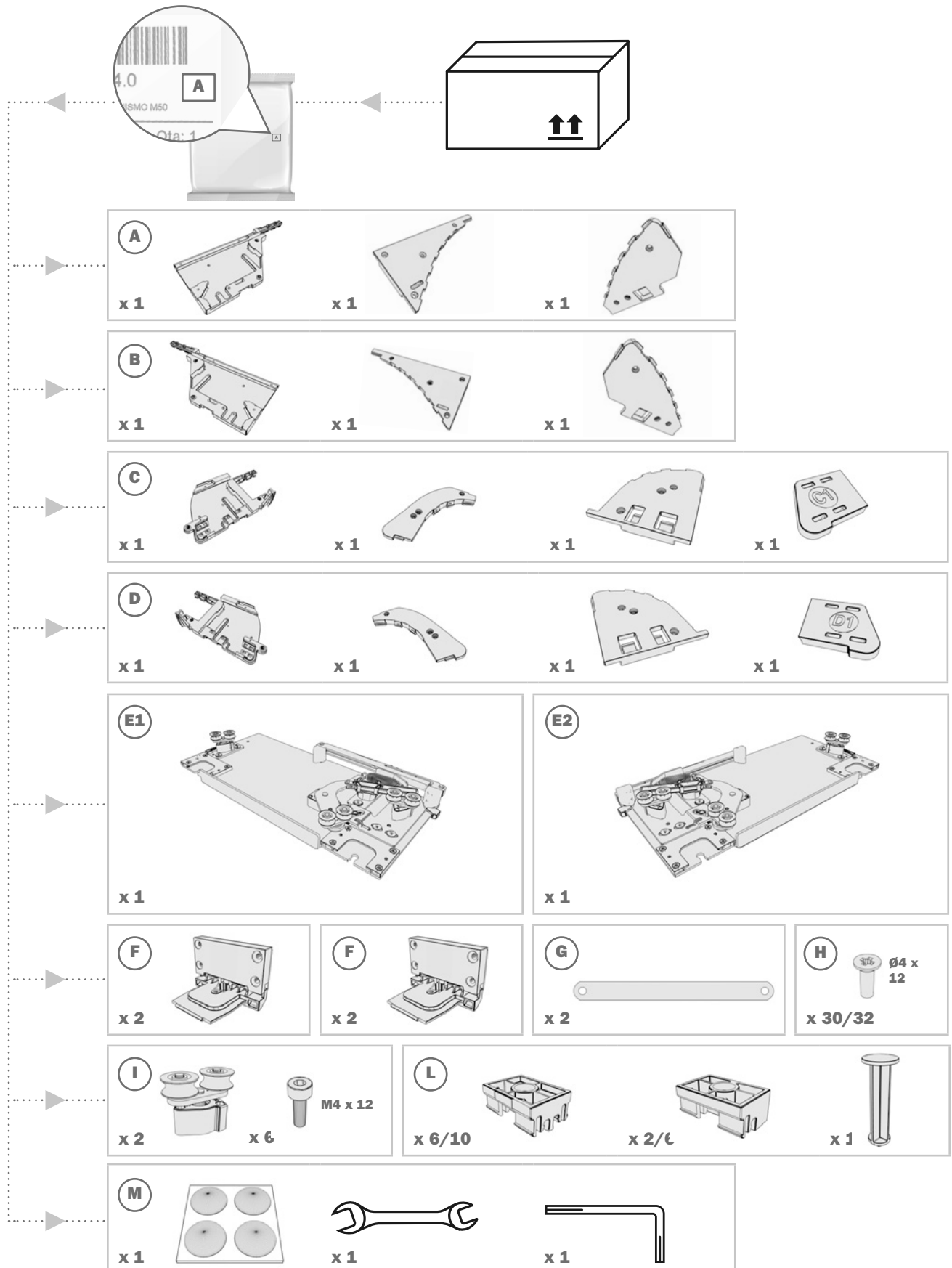

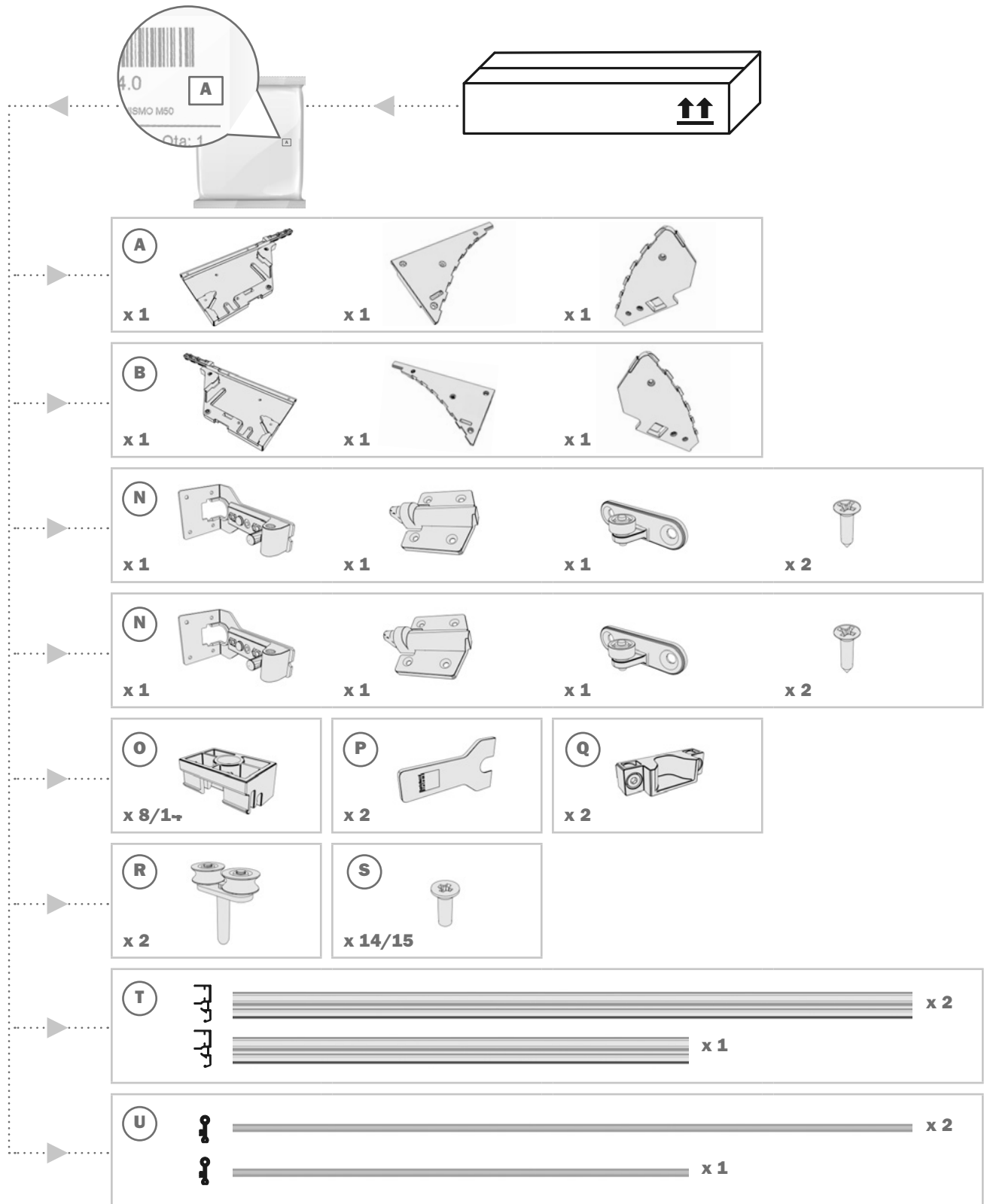

Slider S10

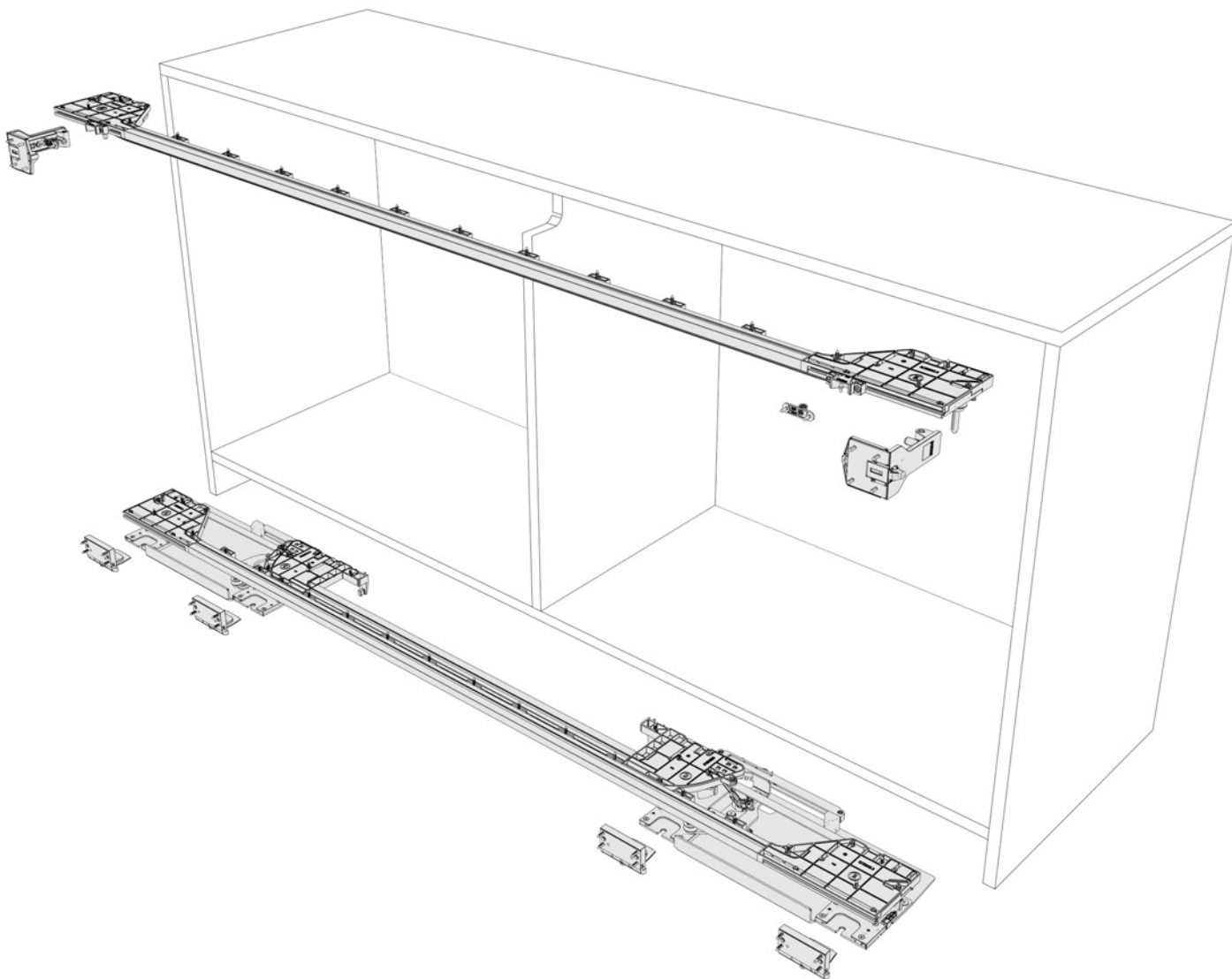

[ITA] TIPOLOGIA DI MONTAGGIO

[ENG] TYPE OF ASSEMBLY

[FRA] TYPE DE MONTAGE

[DEU] MONTAGEART

[ESP] TIPO DE MONTAJE

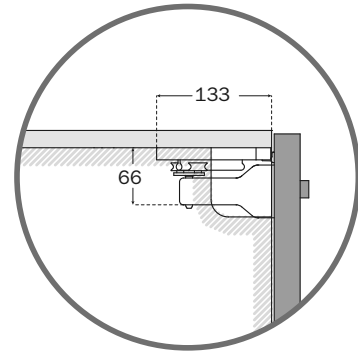
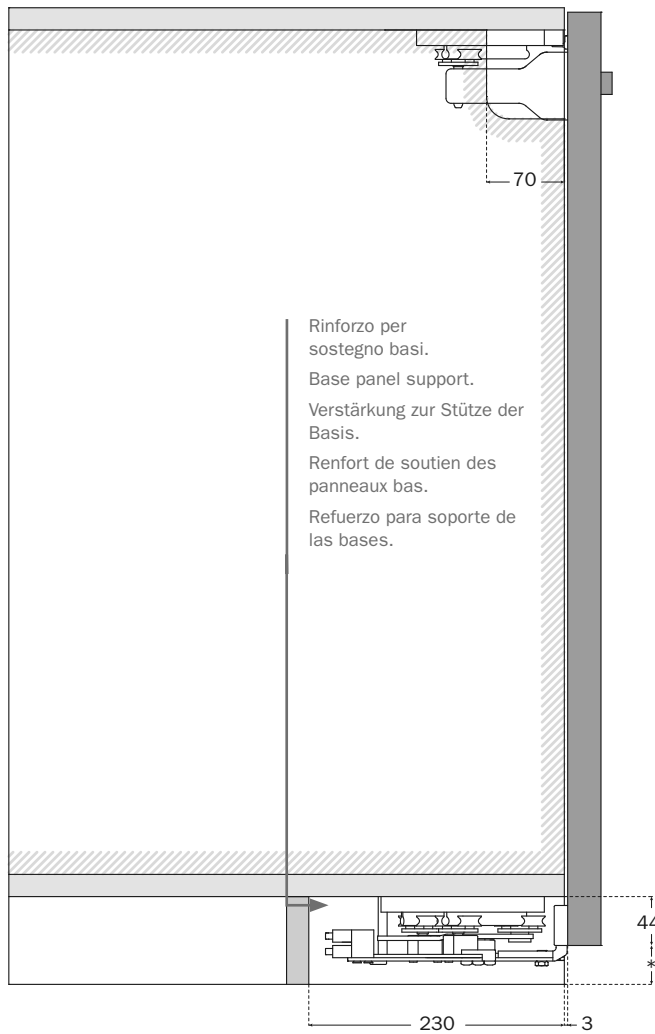

Spazio minimo per fissaggio e regolazione 35 mm.
 Minimum space 35 mm for fastening and adjusting.
 Minimaler Platzbedarf zum Befestigen und Einstellen 35 mm.
 Espace minimum pour la fixation et le réglage de 35 mm.
 Espacio mínimo para la fijación y la regulación de 35 mm.

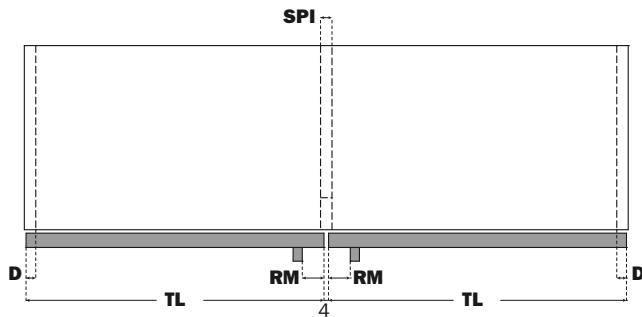
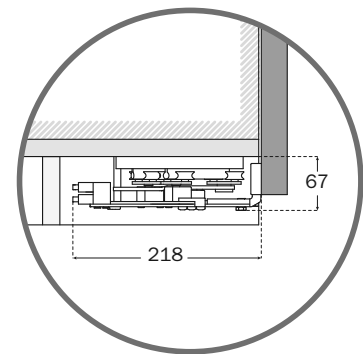

- D** = max 25 mm
- T** = max 30 mm
- TM** = max 40 mm
- RM** = min 10 mm
= max TL/3

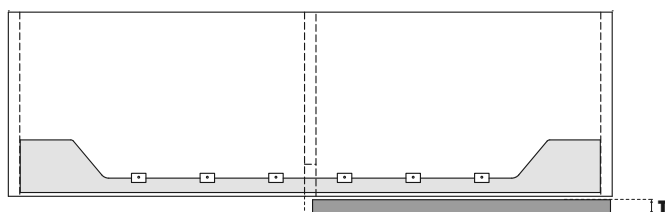

guida intera

Slider S10

[ITA] LAVORAZIONI SULLA STRUTTURA

[ENG] DRILLING AND MACHINING
THE CABINET

[FRA] USINAGE DU MEUBLE

[ESP] TRABAJOS EN LA ESTRUCTURA

[DEU] ARBEITEN AM KORPUS

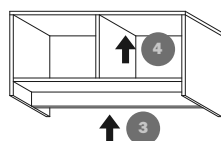
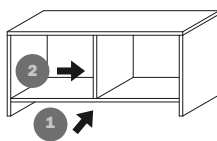
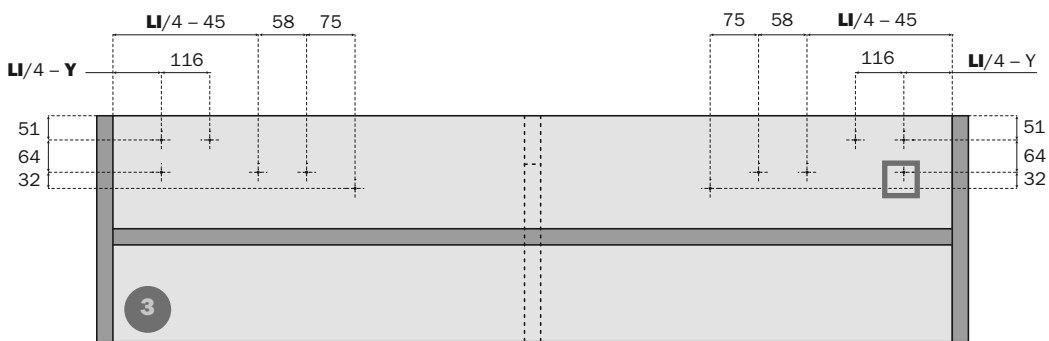
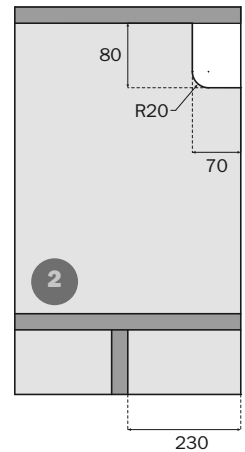
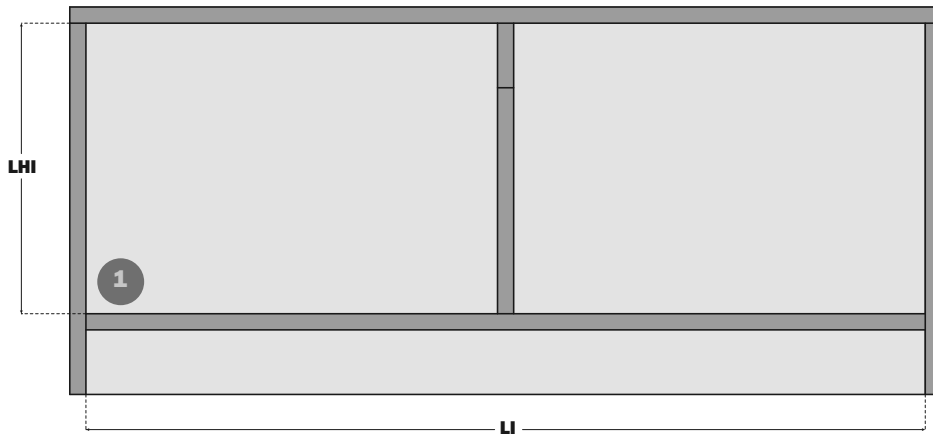

LI (mm)	Y (mm)
860-987	161
988-1115	193
1116-1371	225
1372-1627	289
1628-1883	353
1884-2139	417
2140-2400	481

[ITA] LAVORAZIONI SULL'ANTA

[ENG] WORKING ON THE DOOR

[FRA] PLAN DE PERÇAGE DE LA PORTE

[DEU] BEARBEITUNG DER TÜR

[ESP] TRABAJOS EN LA PUERTA

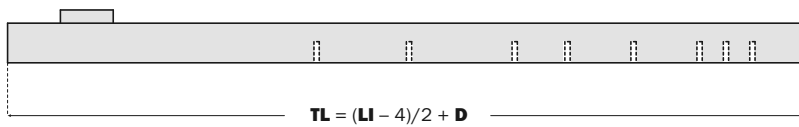
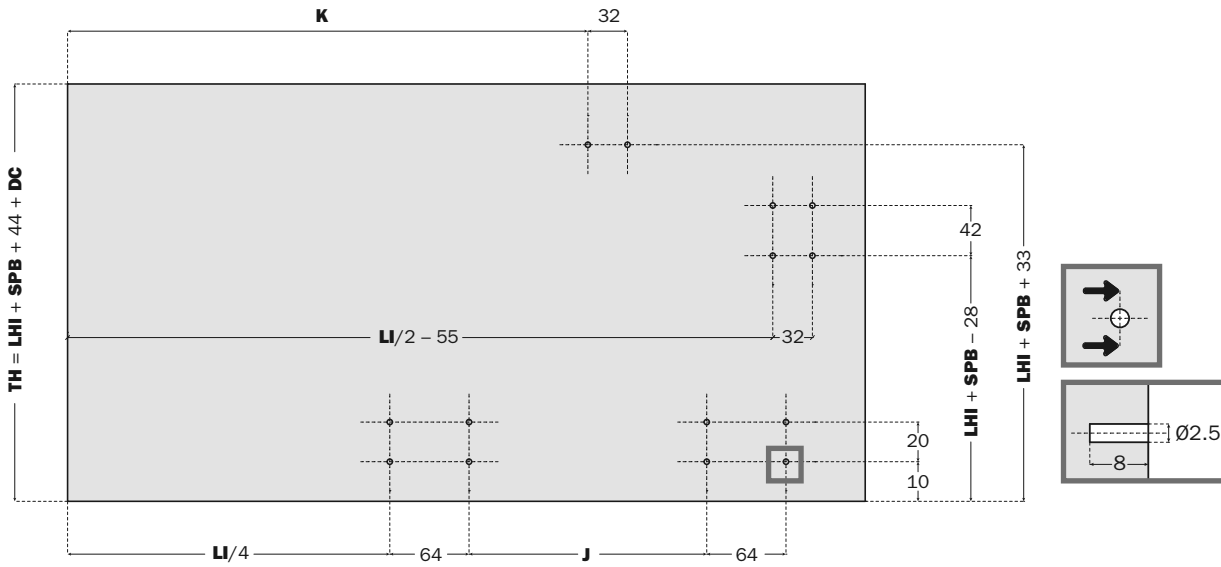

LI (mm)	J (mm)	K (mm)
860-987	64	
988-1115	96	
1116-1371	128	4 x LI/10 + 24
1372-1627	192	
1628-1883	256	
1884-2139	320	
2140-2400	384	LI/2 - 176

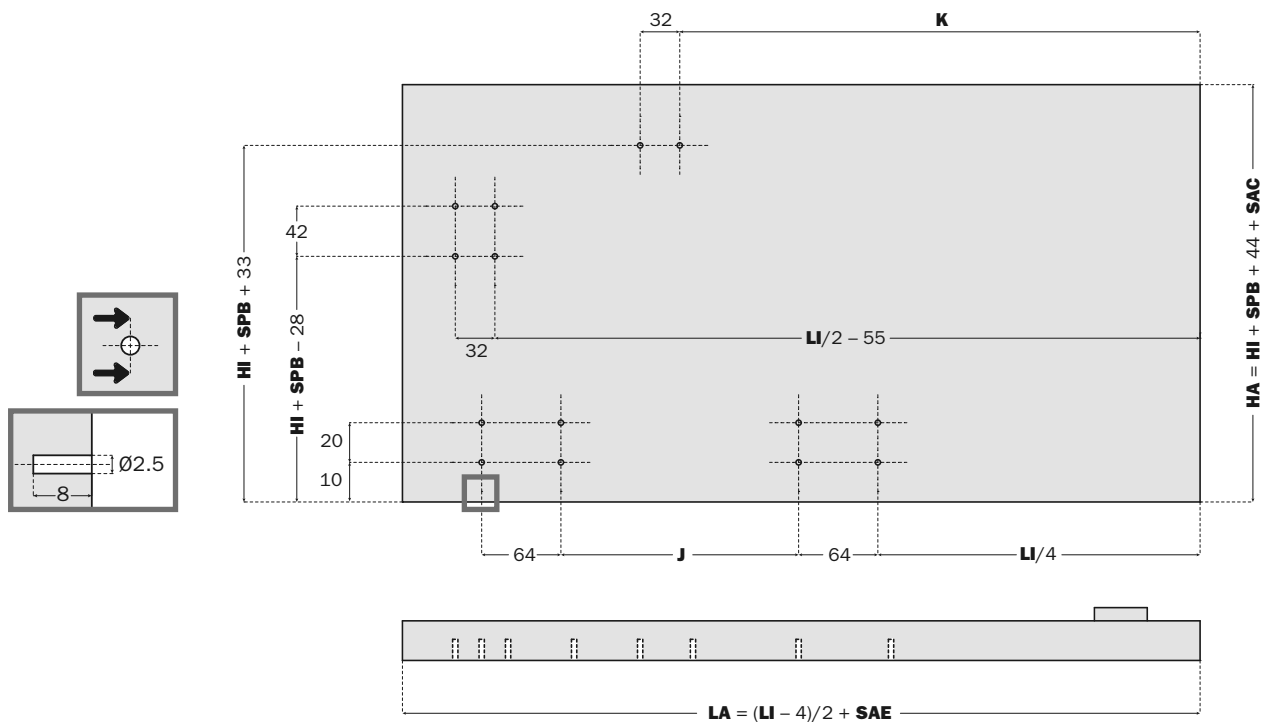

Slider S10

[ITA] TAGLIO DEI PROFILI SUPERIORI

[ENG] CUTTING THE UPPER PROFILES

[FRA] DÉCOUPE DES PROFILÉS HAUTE

[DEU] ZUSCHNEIDEN DER OBEREN PROFILE

[ESP] CORTE DE LOS PERFILES SUPERIORES

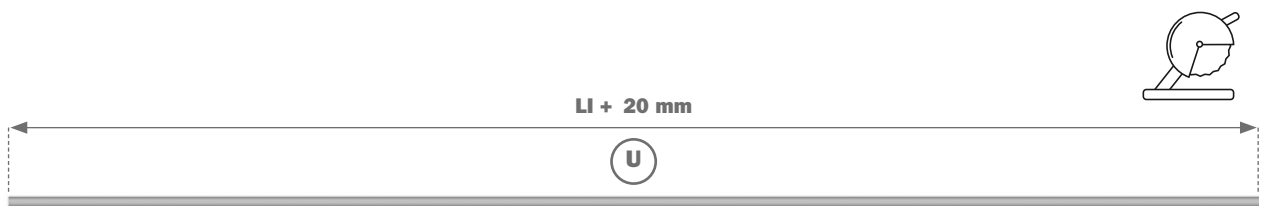
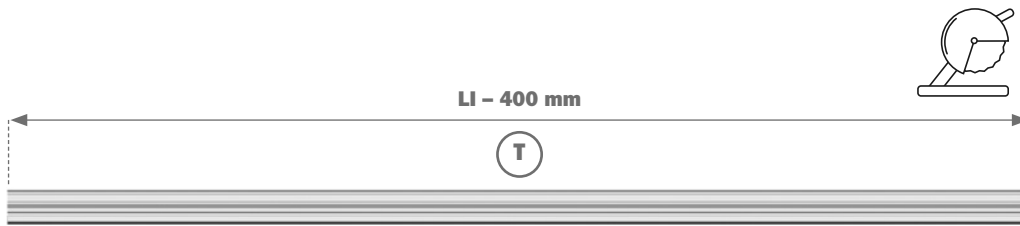

[ITA] MONTAGGIO DEL MECCANISMO SUPERIORE

[ENG] ASSEMBLING THE UPPER MECHANISM

[FRA] MONTAGE DU MÉCANISME HAUT

[DEU] MONTAGE DES OBEREN MECHANISMUS

[ESP] MONTAJE DEL MECANISMO SUPERIOR

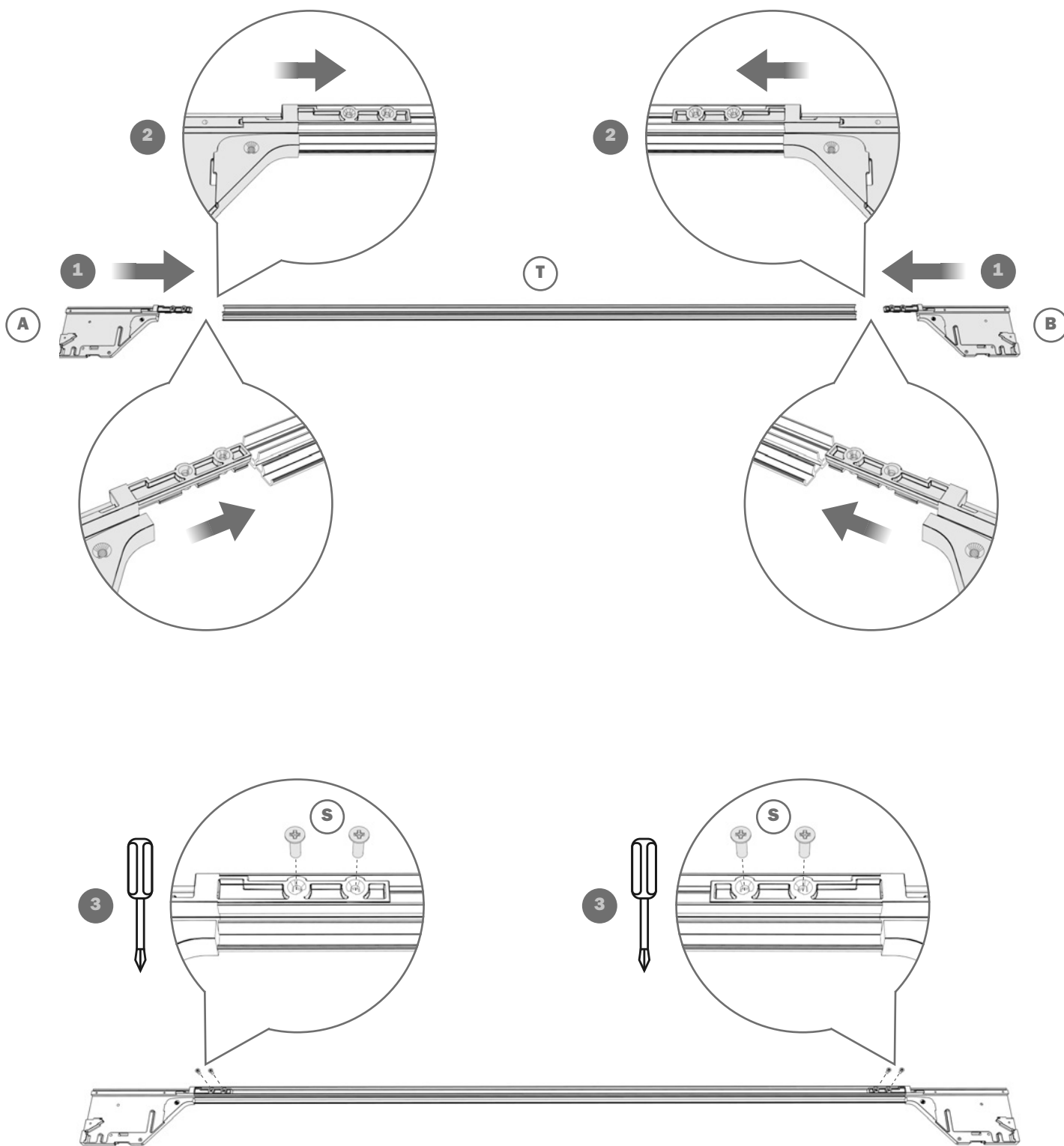

Slider S10

[ITA] MONTAGGIO DEL MECCANISMO SUPERIORE

[ENG] ASSEMBLING THE UPPER MECHANISM

[FRA] MONTAGE DU MÉCANISME HAUT

[ESP] MONTAJE DEL MECANISMO SUPERIOR

[DEU] MONTAGE DES OBEREN MECHANISMUS

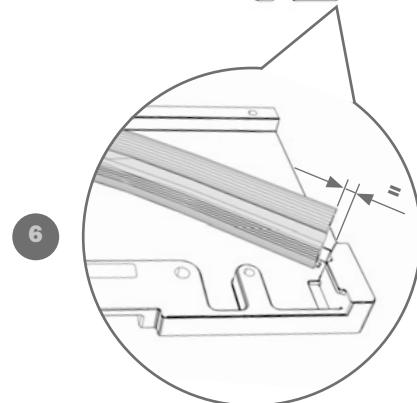
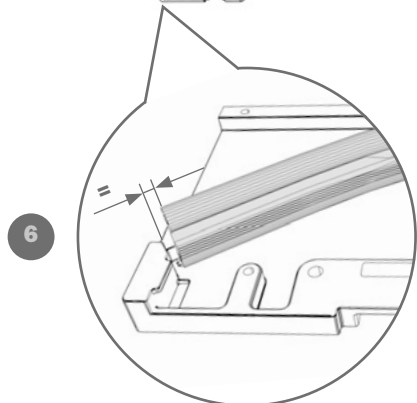
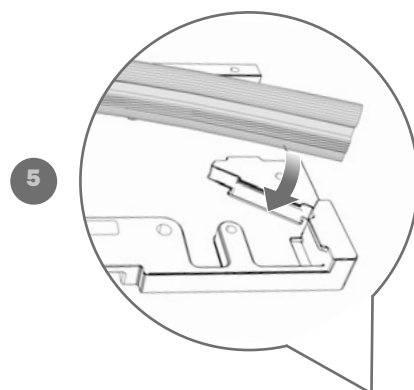
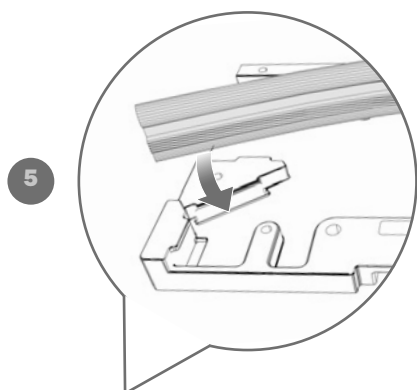
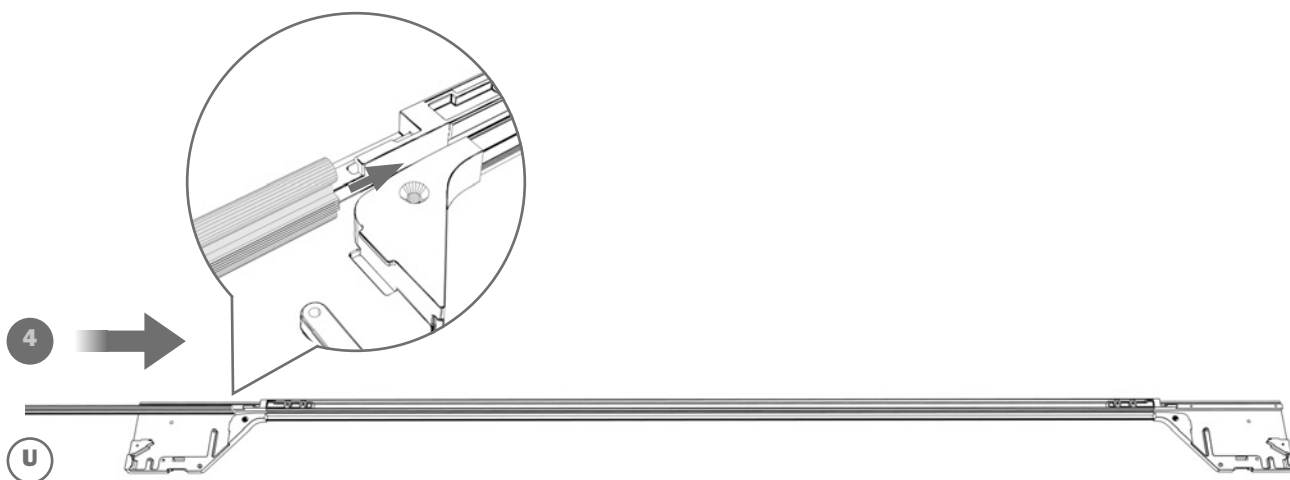

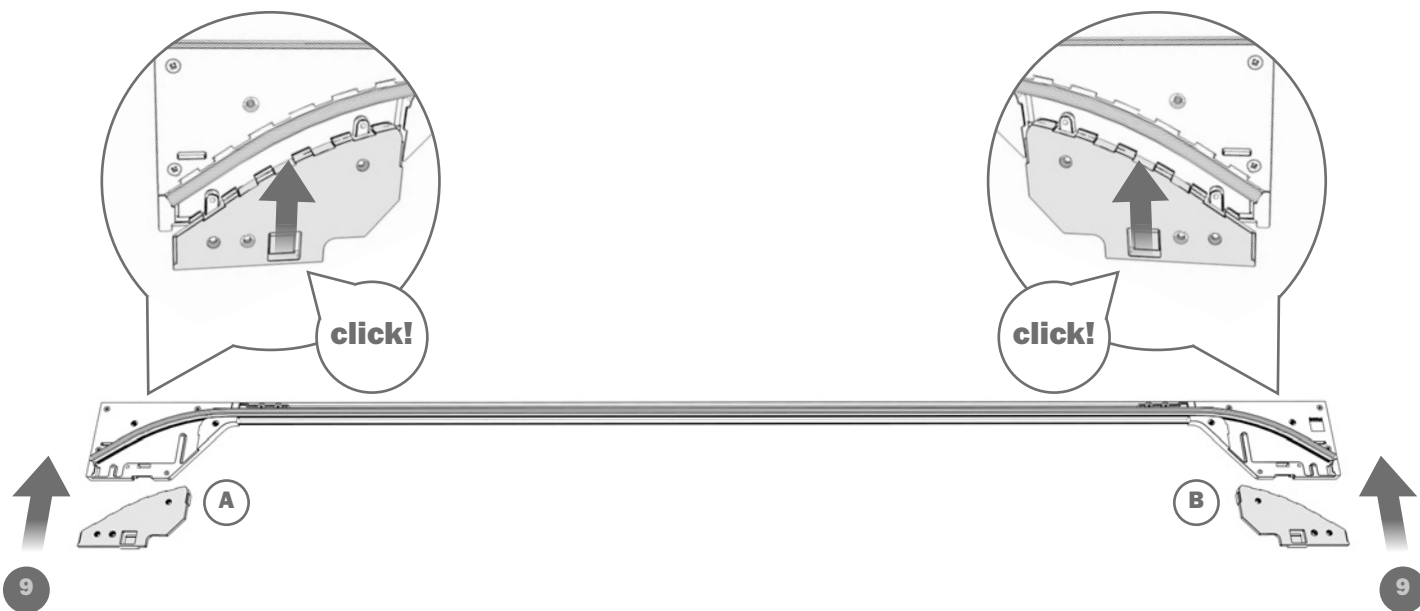
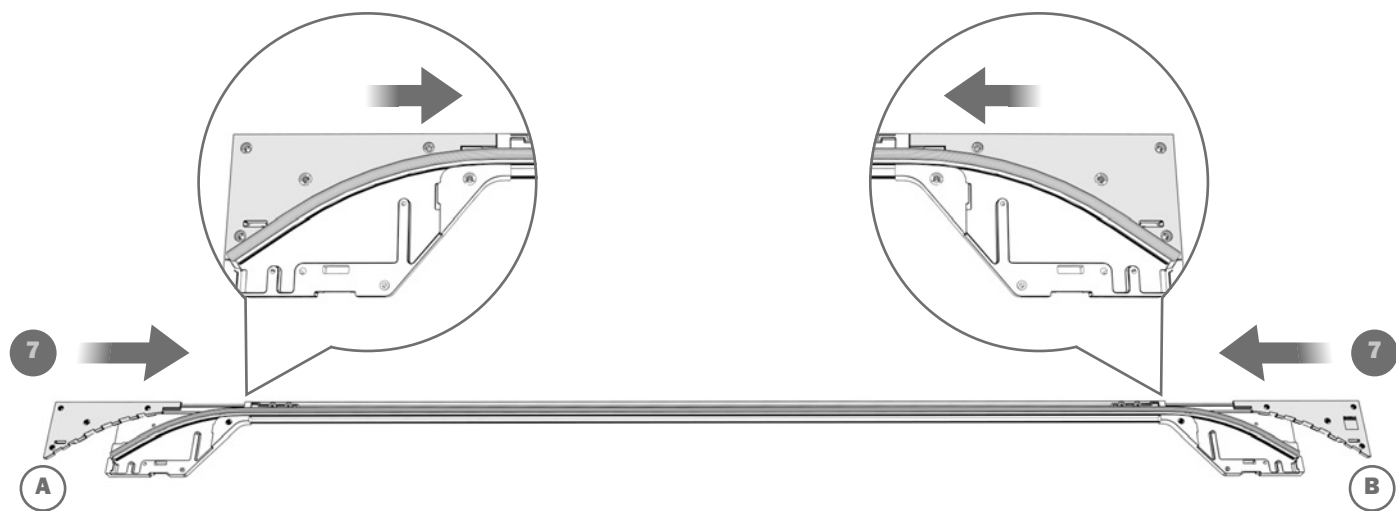

Slider S10

[ITA] MONTAGGIO DEL MECCANISMO SUPERIORE

[ENG] ASSEMBLING THE UPPER MECHANISM

[FRA] MONTAGE DU MÉCANISME HAUT

[DEU] MONTAGE DES OBEREN MECHANISMUS

[ESP] MONTAJE DEL MECANISMO SUPERIOR

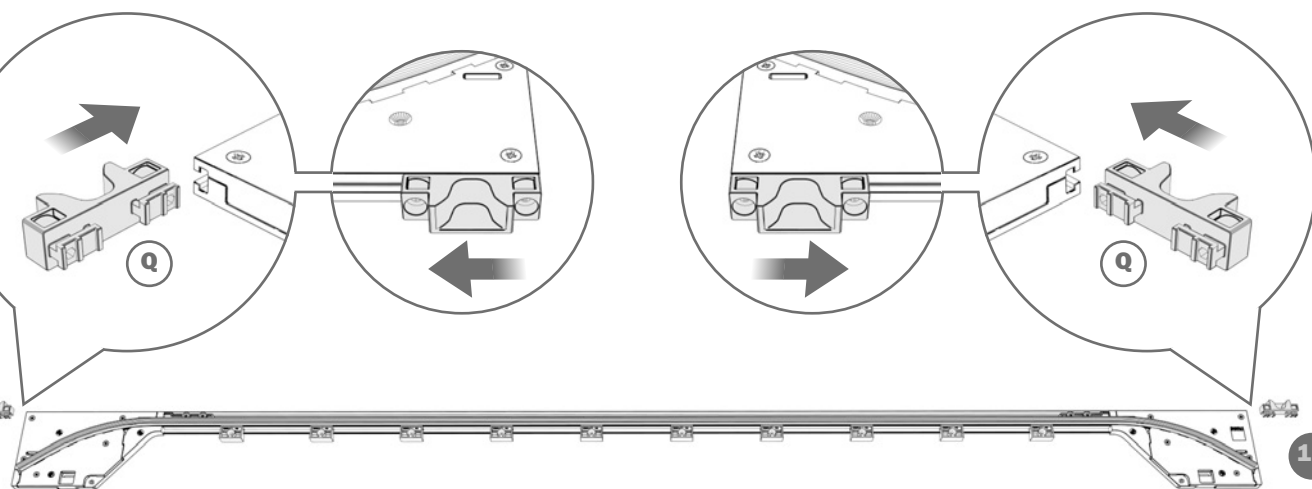
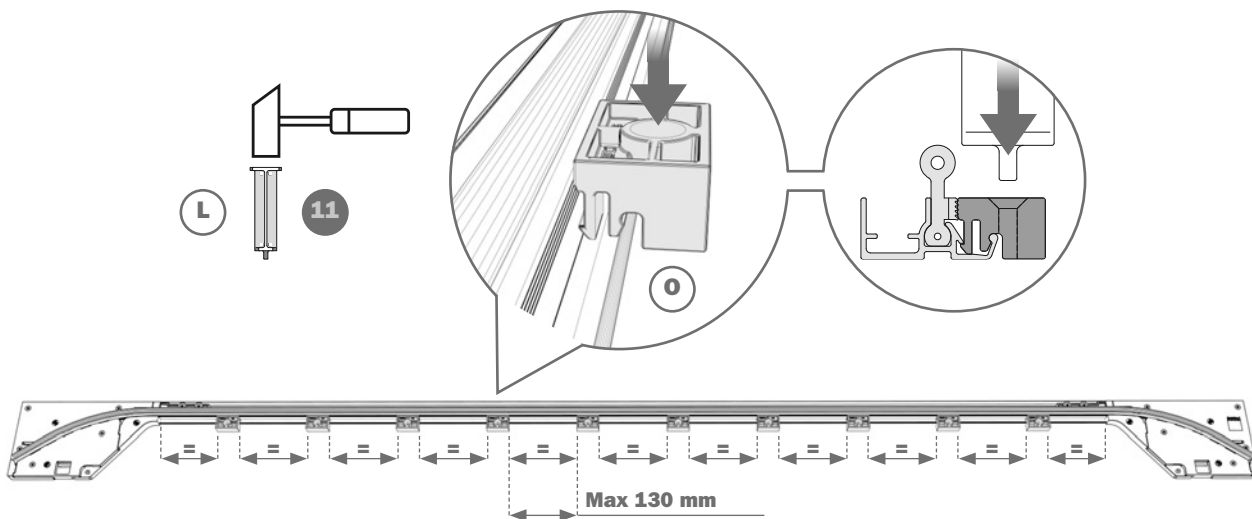

[ITA] TAGLIO DEI PROFILI INFERIORI

[ENG] CUTTING THE LOWER PROFILES

[FRA] DÉCOUPE DES PROFILÉS BAS

[DEU] ZUSCHNITT DER UNTEREN PROFILE

[ESP] CORTE DE LOS PERFILES INFERIORES



LI (mm)	X (mm)
860-987	30
988-1115	94
1116-1371	158
1372-1627	286
1628-1883	414
1884-2139	542
2140-2400	670

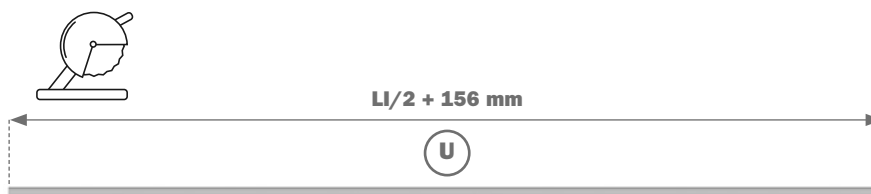
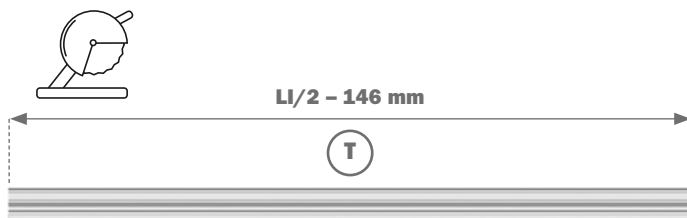
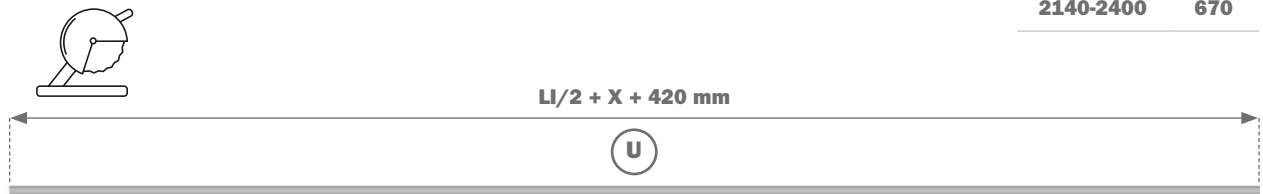
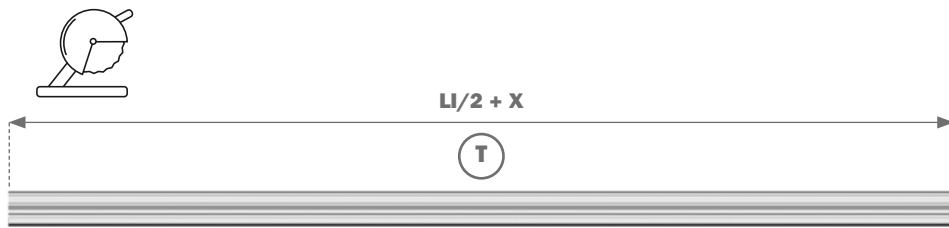

Slider S10

[ITA] MONTAGGIO DEL MECCANISMO INFERIORE

[ENG] ASSEMBLING THE LOWER MECHANISM

[FRA] MONTAGE DU MÉCANISME BAS

[DEU] MONTAGE DES UNTEREN MECHANISMUS

[ESP] MONTAJE DEL MECANISMO INFERIOR

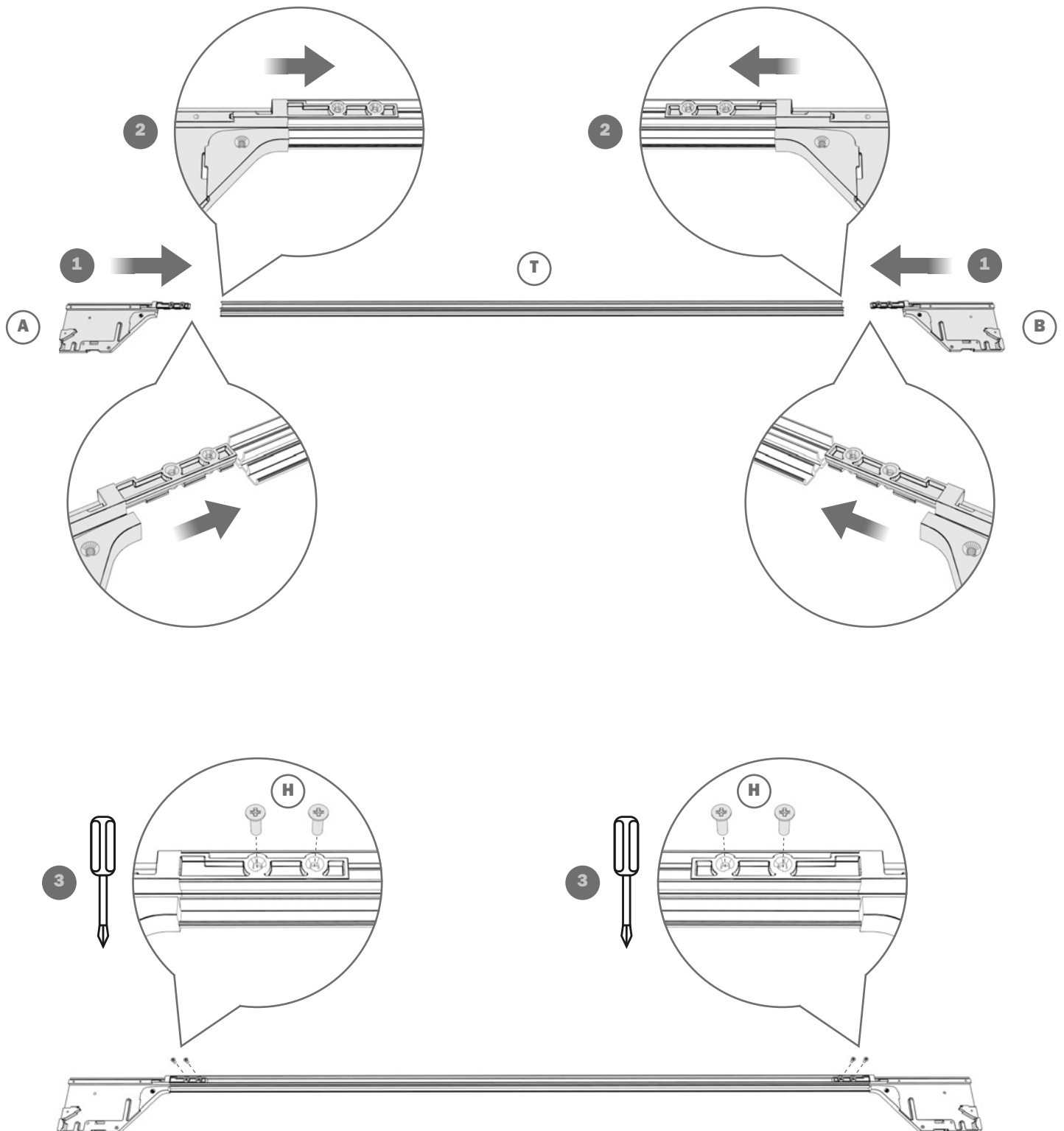

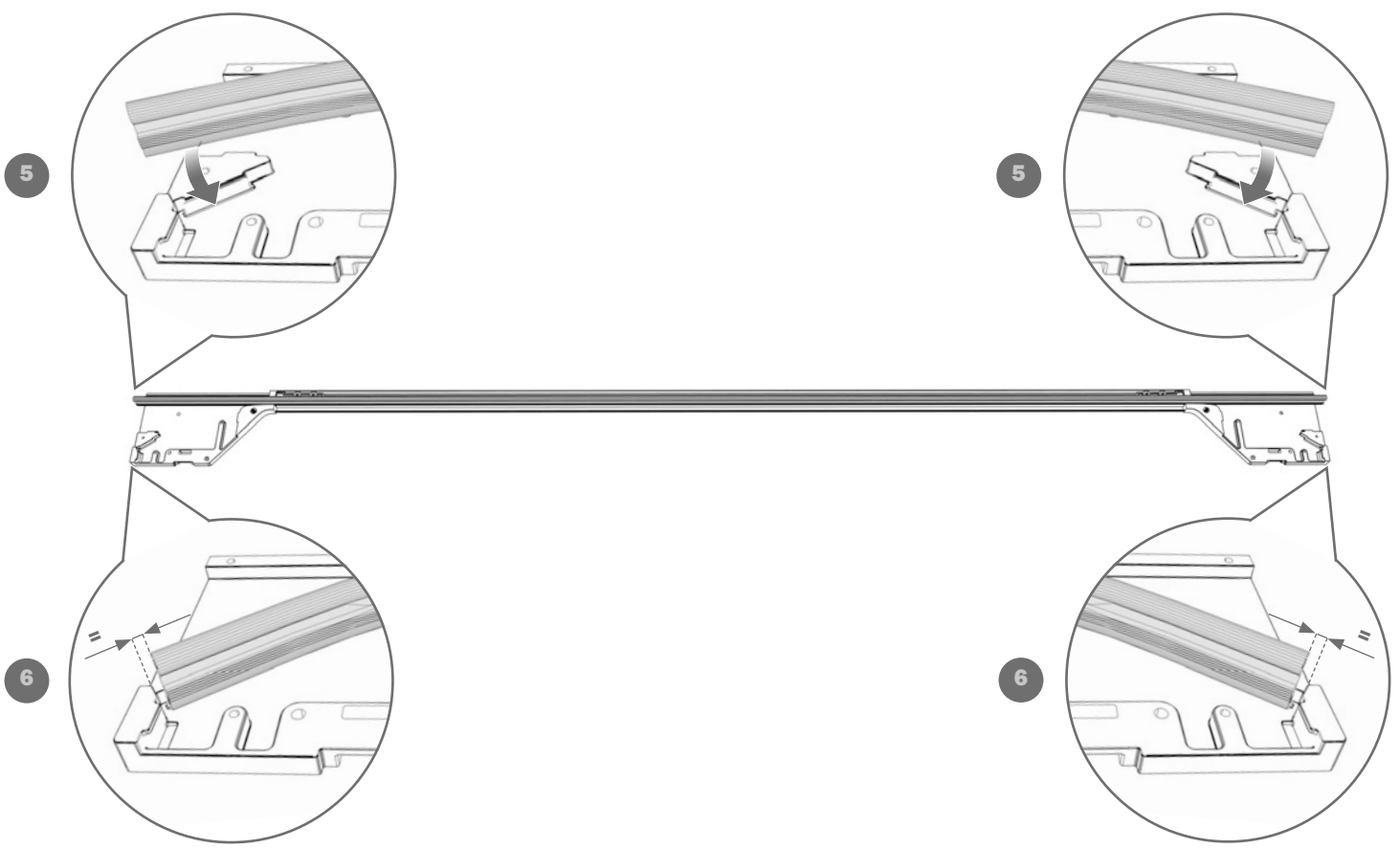
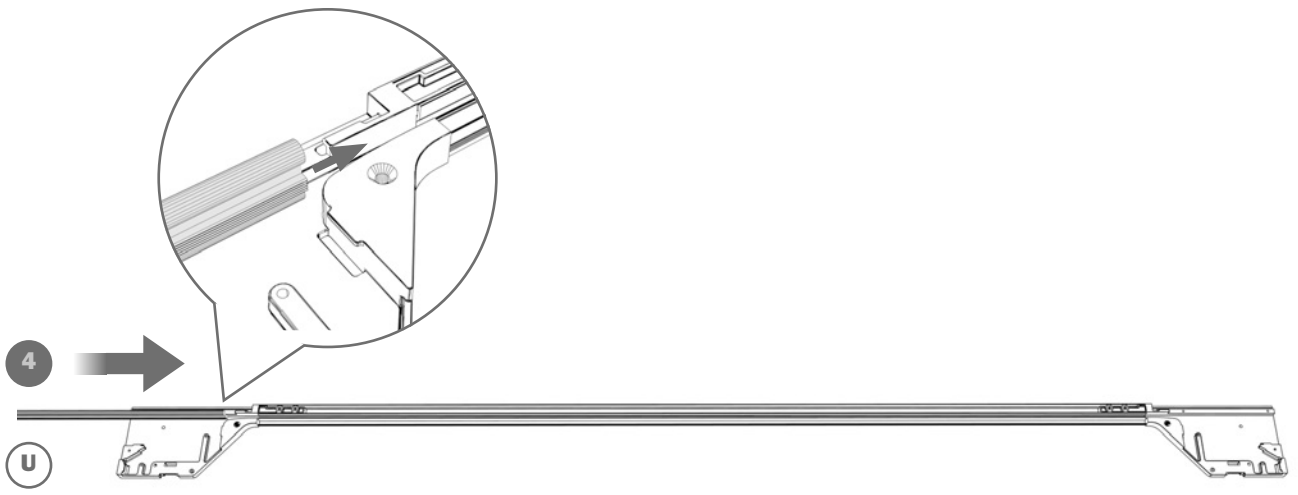

Slider S10

[ITA] MONTAGGIO DEL MECCANISMO INFERIORE

[ENG] ASSEMBLING THE LOWER MECHANISM

[FRA] MONTAGE DU MÉCANISME BAS

[DEU] MONTAGE DES UNTEREN MECHANISMUS

[ESP] MONTAJE DEL MECANISMO INFERIOR

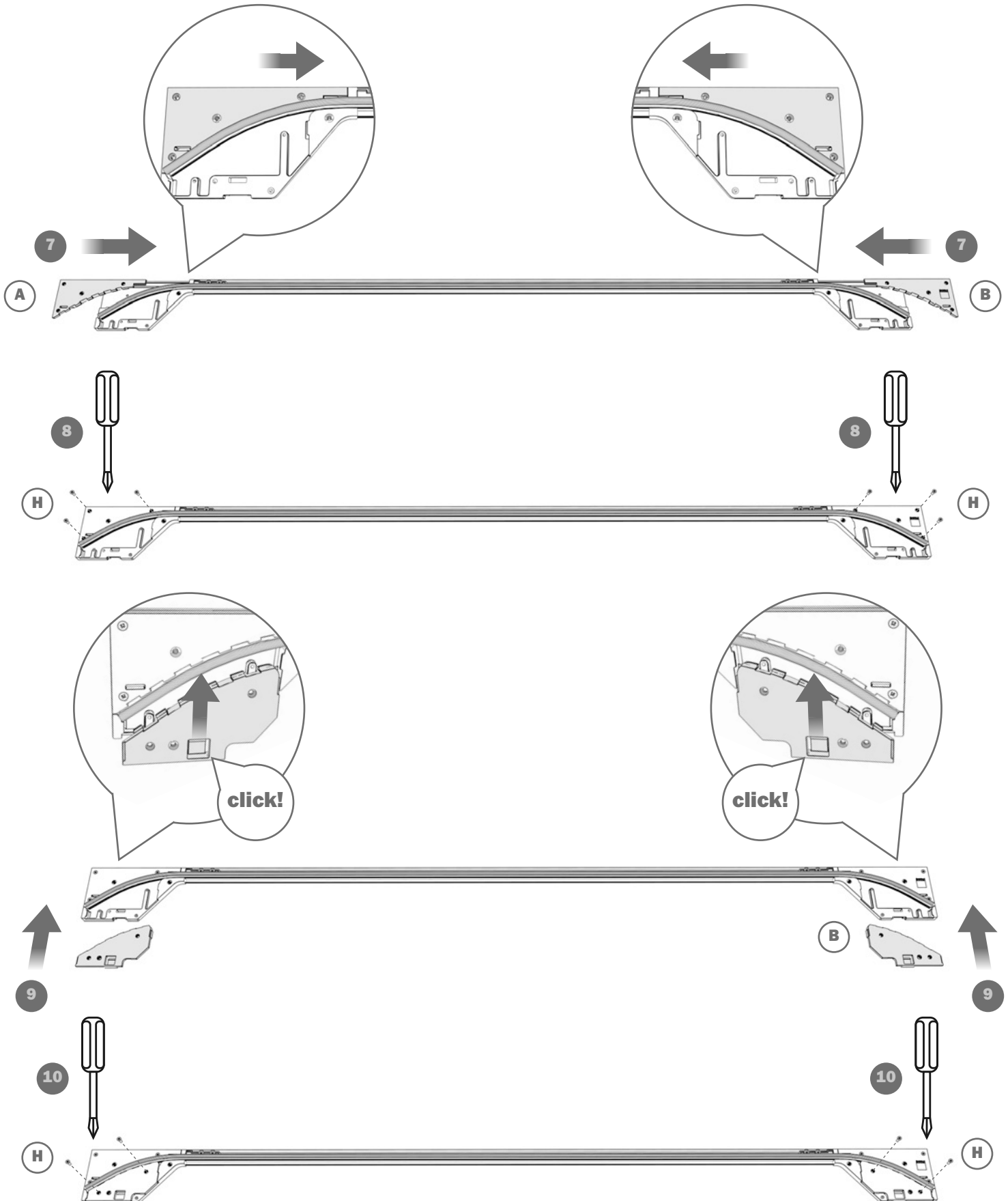

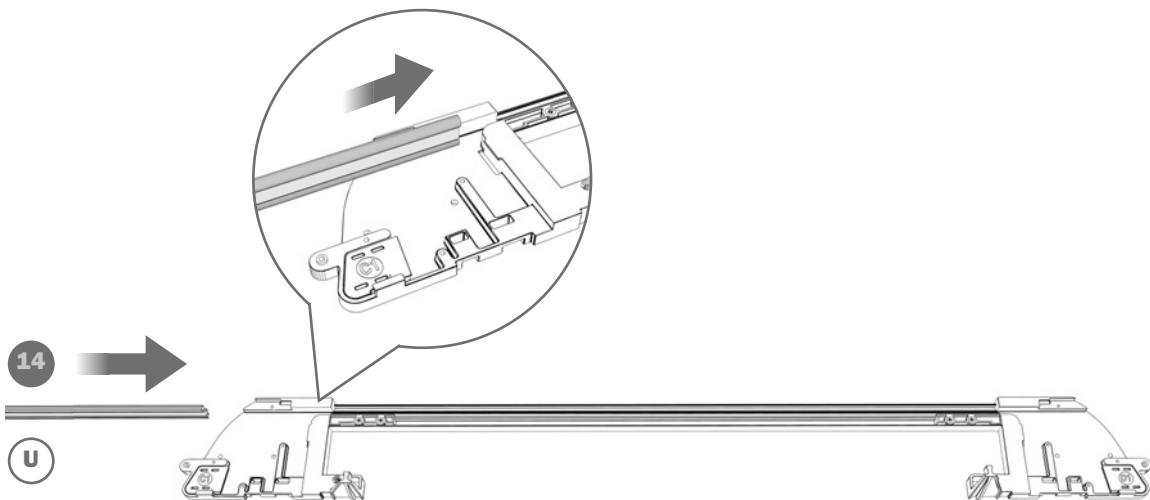
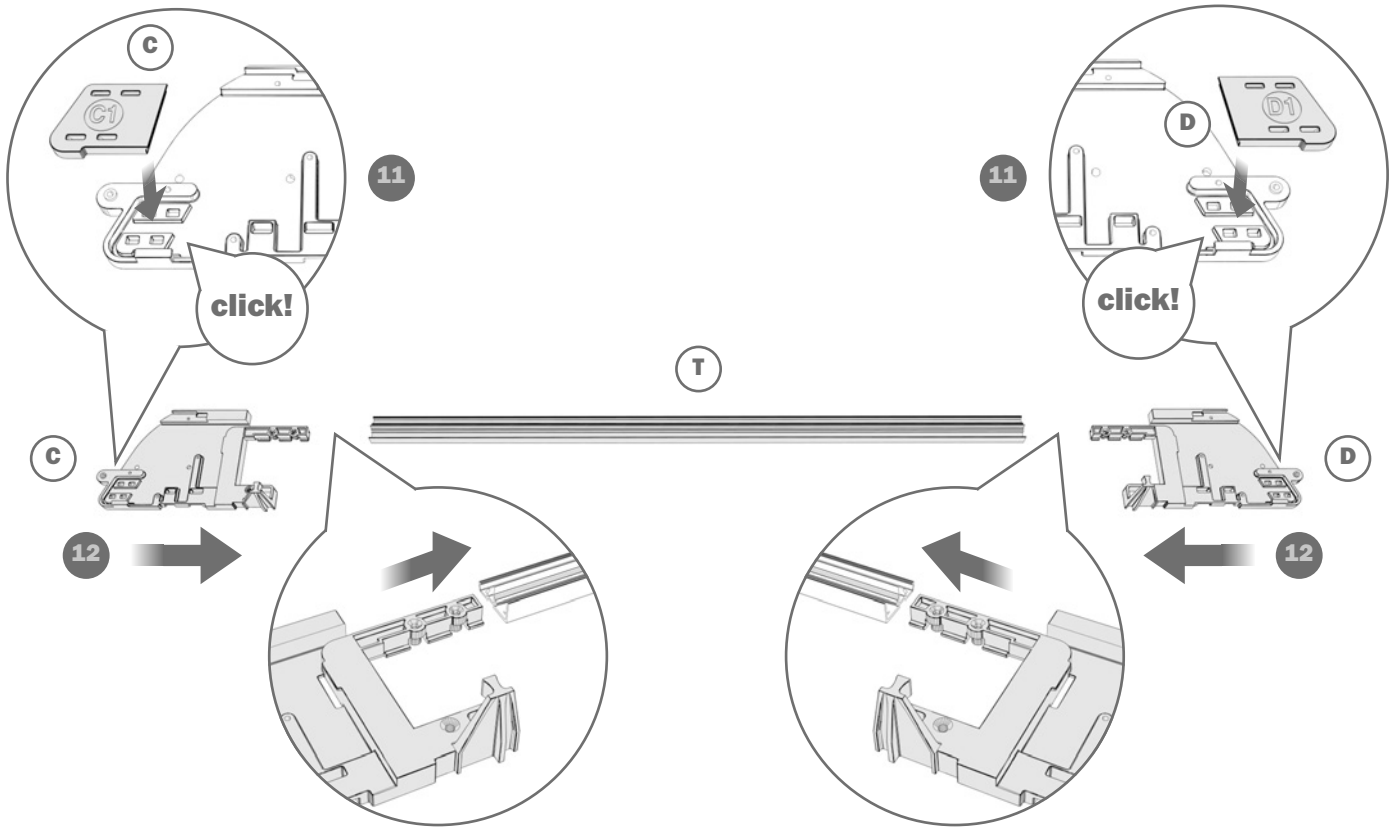

Slider S10

[ITA] MONTAGGIO DEL MECCANISMO INFERIORE

[ENG] ASSEMBLING THE LOWER MECHANISM

[FRA] MONTAGE DU MÉCANISME BAS

[DEU] MONTAGE DES UNTEREN MECHANISMUS

[ESP] MONTAJE DEL MECANISMO INFERIOR

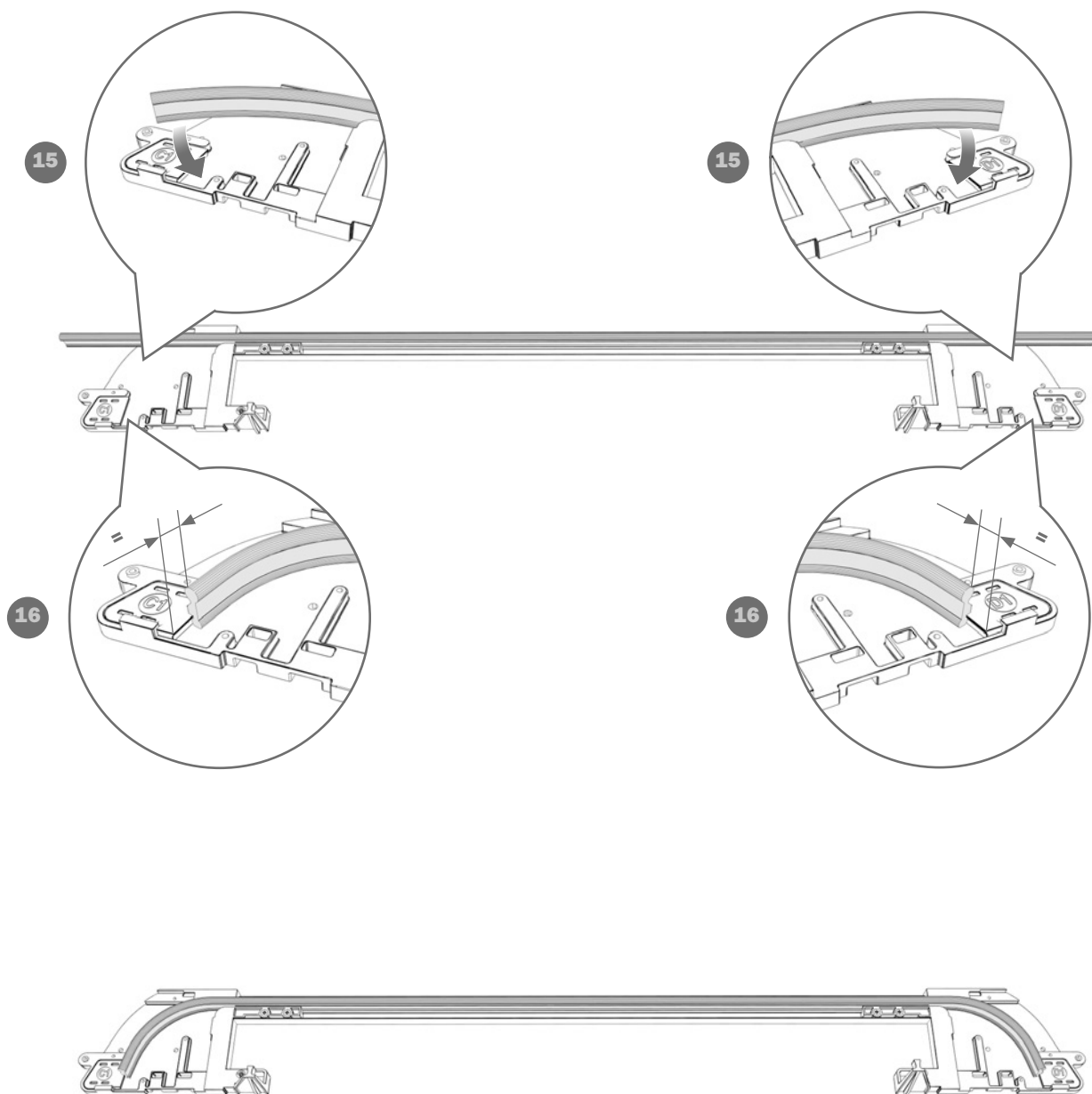

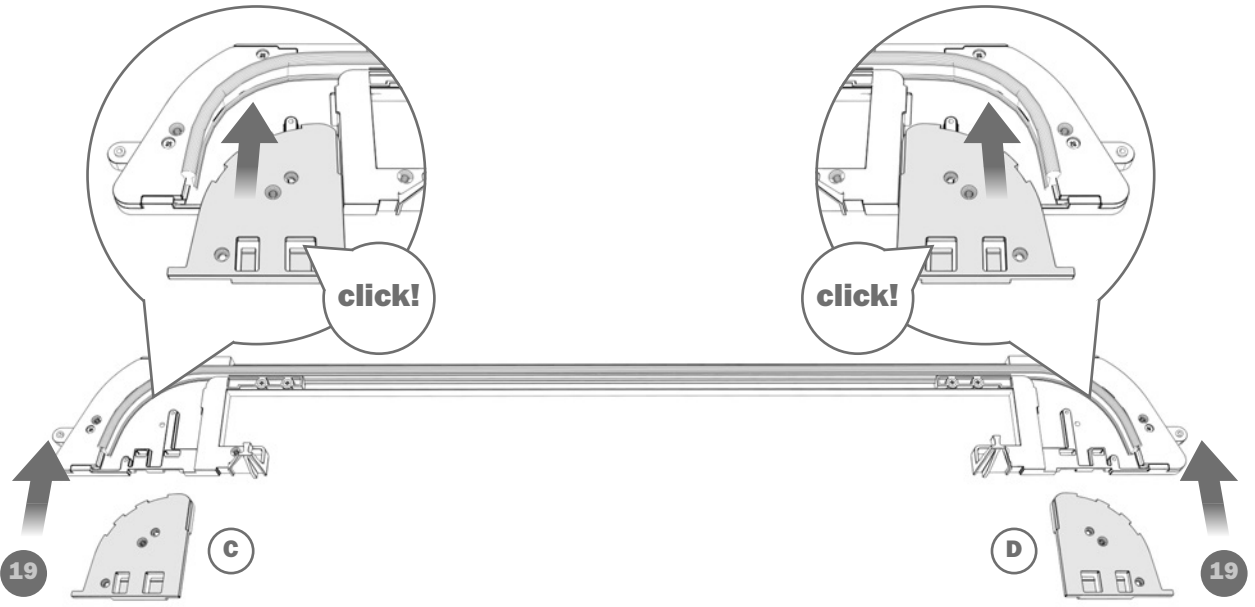
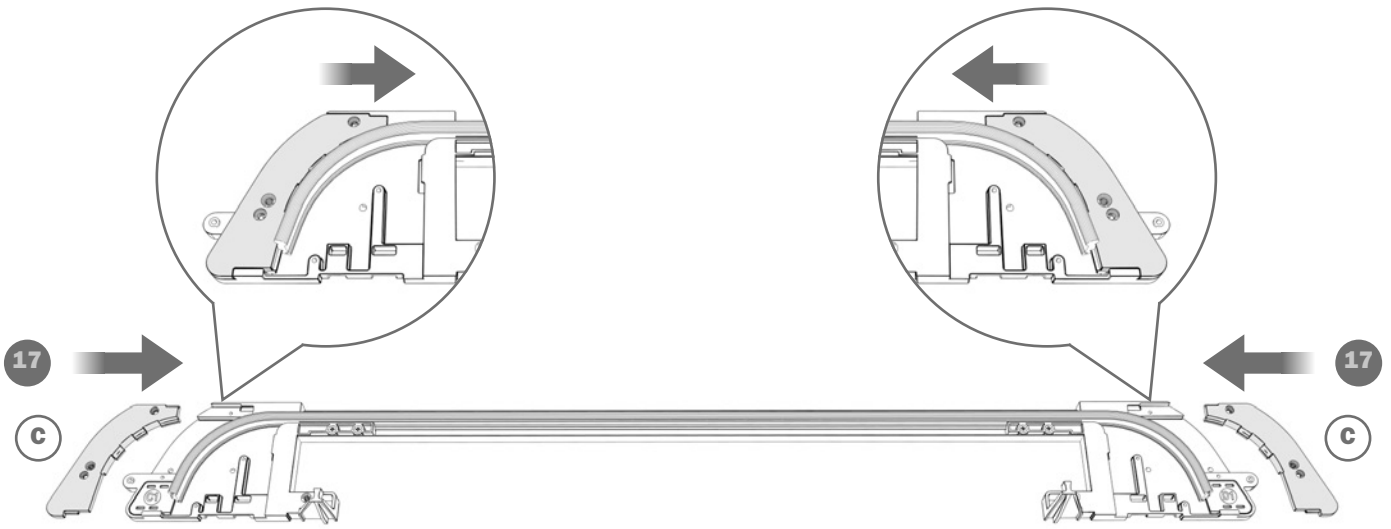

Slider S10

[ITA] MONTAGGIO DEL MECCANISMO INFERIORE

[ENG] ASSEMBLING THE LOWER MECHANISM

[FRA] MONTAGE DU MÉCANISME BAS

[DEU] MONTAGE DES UNTEREN MECHANISMUS

[ESP] MONTAJE DEL MECANISMO INFERIOR

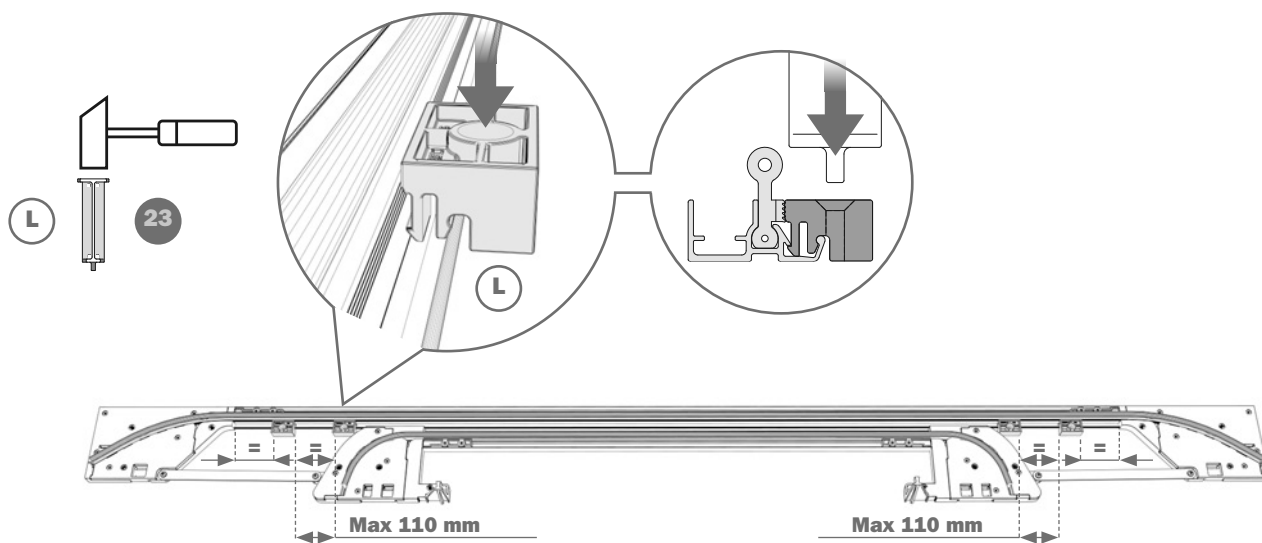
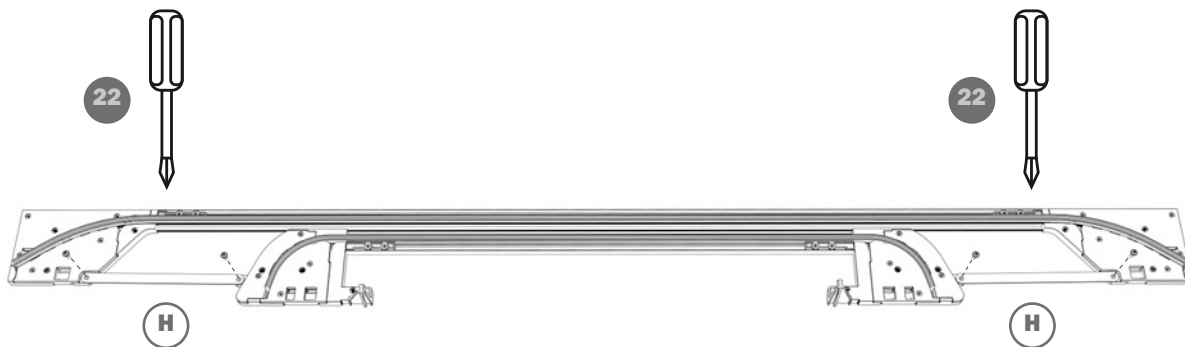

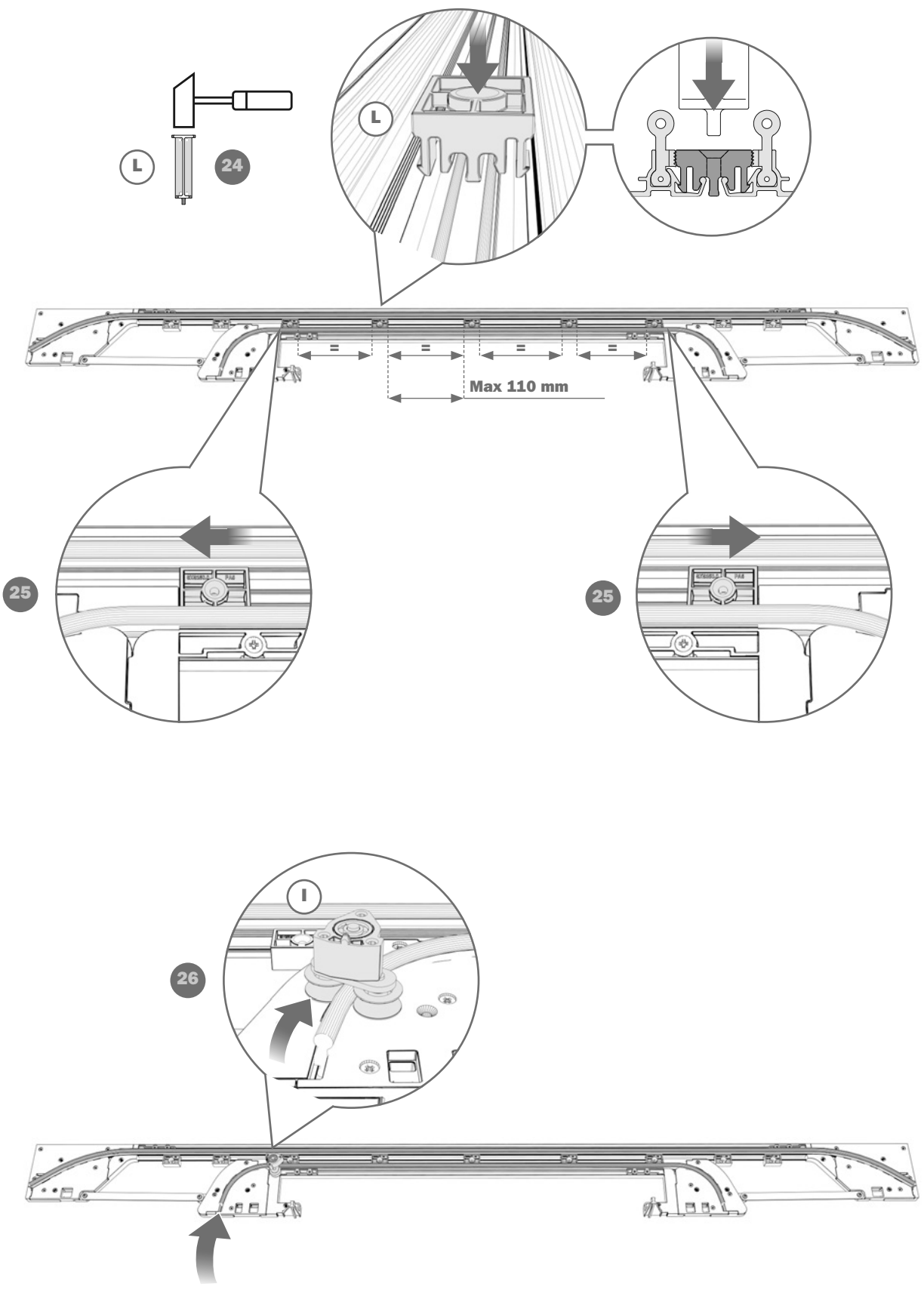

Slider S10

[ITA] MONTAGGIO DEL MECCANISMO INFERIORE

[ENG] ASSEMBLING THE LOWER MECHANISM

[FRA] MONTAGE DU MÉCANISME BAS

[DEU] MONTAGE DES UNTEREN MECHANISMUS

[ESP] MONTAJE DEL MECANISMO INFERIOR

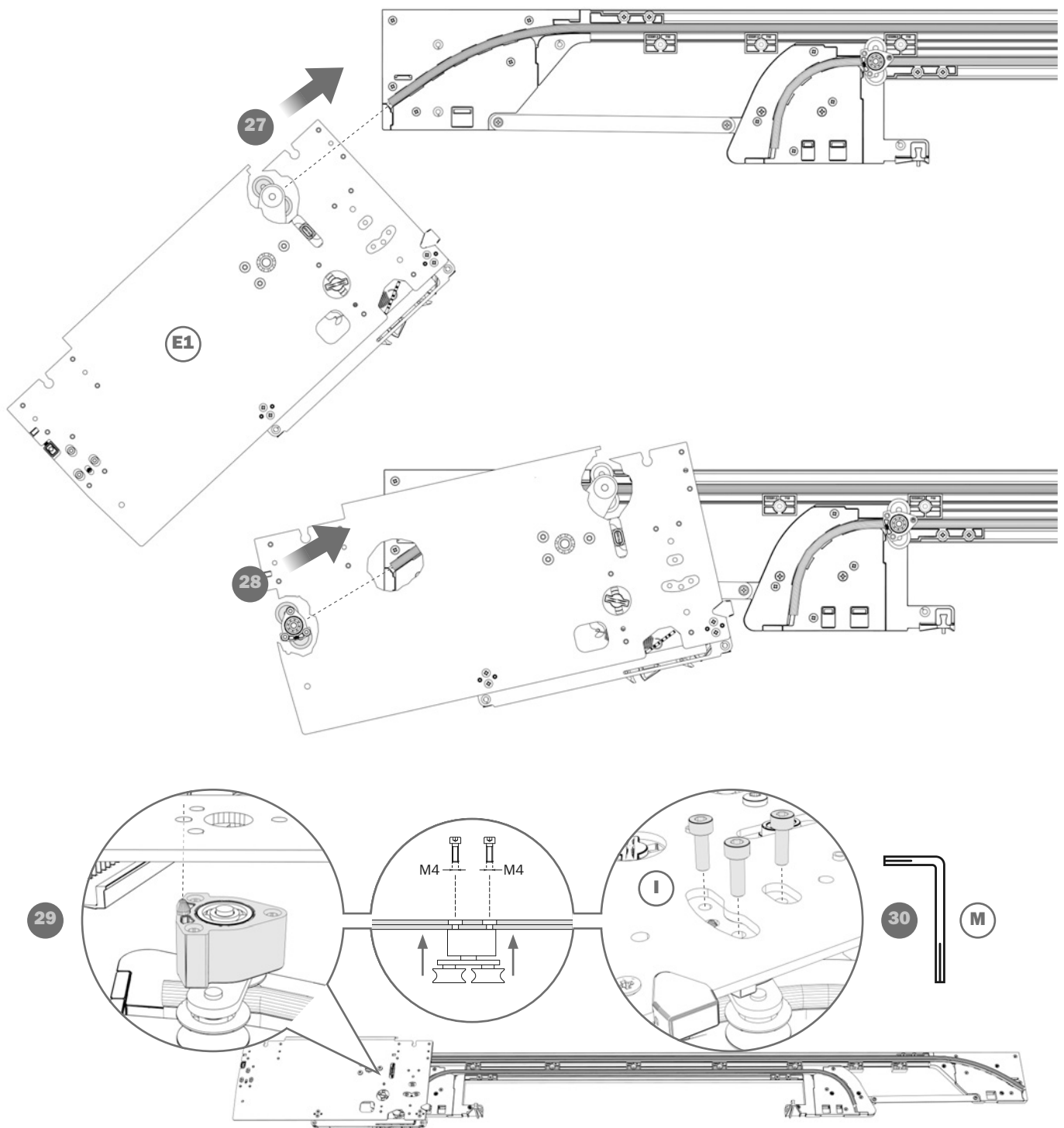

[ITA] Per il carrello destro, ripetere la sequenza delle operazioni da 26 a 30.

[ENG] For the right-hand carriage, repeat the steps from 26 to 30.

[FRA] Pour le rail droit, répéter la étapes des opérations de 26 à 30.

[DEU] Auf der rechten Seite die Abfolge der Tätigkeiten von 26 bis 30 wiederholen.

[ESP] Para el carril derecho, repetir la secuencia de las operaciones desde la 26 hasta la 30.

[ITA] MONTAGGIO DEL MECCANISMO SULLA STRUTTURA

[ENG] INSTALLING THE LOWER MECHANISM ONTO THE CABINET

[FRA] MONTAGE DU MÉCANISME SUR LE MEUBLE

[DEU] MONTAGE DES MECHANISMUS AM KORPUS

[ESP] MONTAJE DEL MECANISMO EN LA ESTRUCTURA

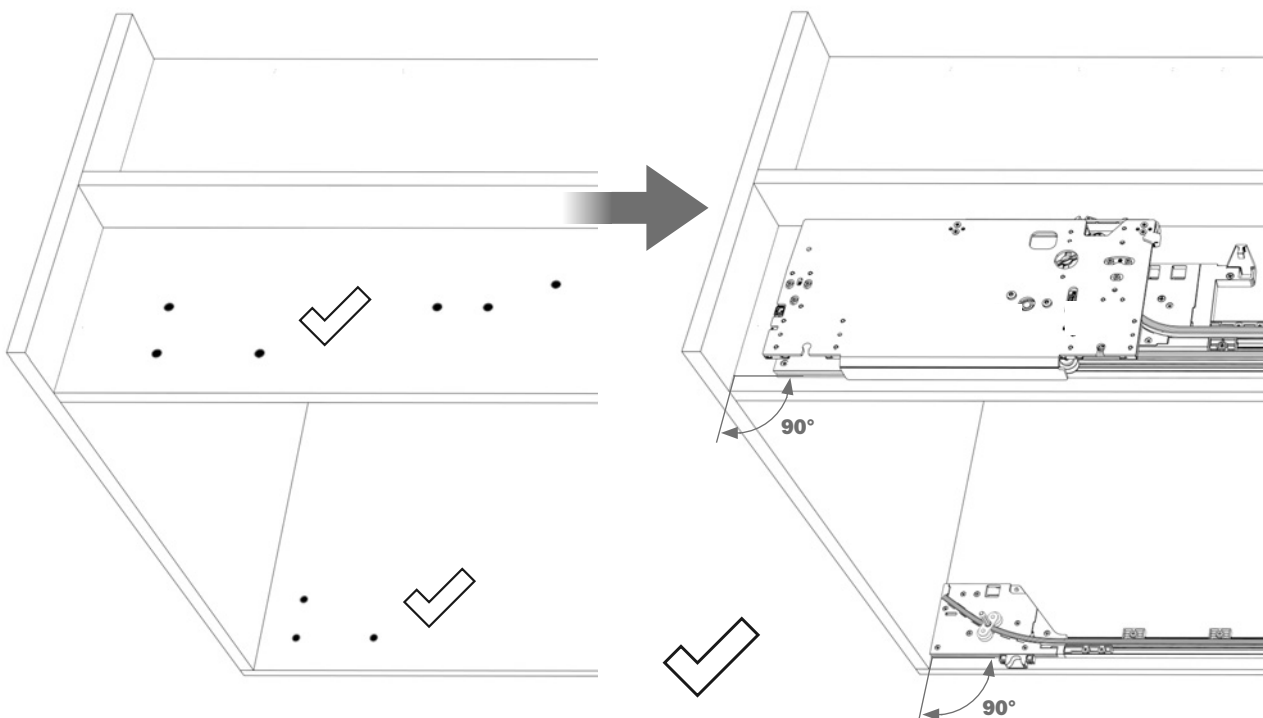
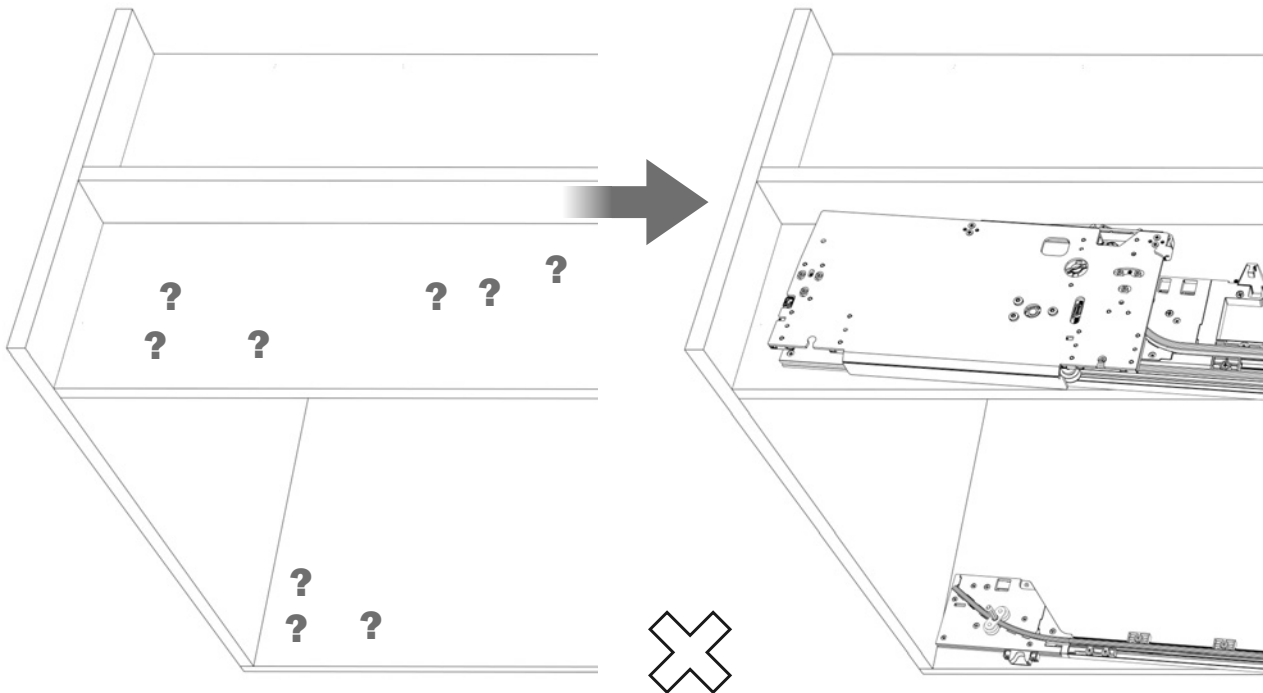

Slider S10

[ITA] MONTAGGIO DEL MECCANISMO INFERIORE SULLA STRUTTURA

[ENG] ASSEMBLING THE LOWER MECHANISM ON THE STRUCTURE

[FRA] MONTAGE DU MÉCANISME BAS SUR LE MEUBLE

[DEU] MONTAGE DES UNTEREN MECHANISMUS AM KORPUS

[ESP] MONTAJE DEL MECANISMO INFERIOR EN LA ESTRUCTURA

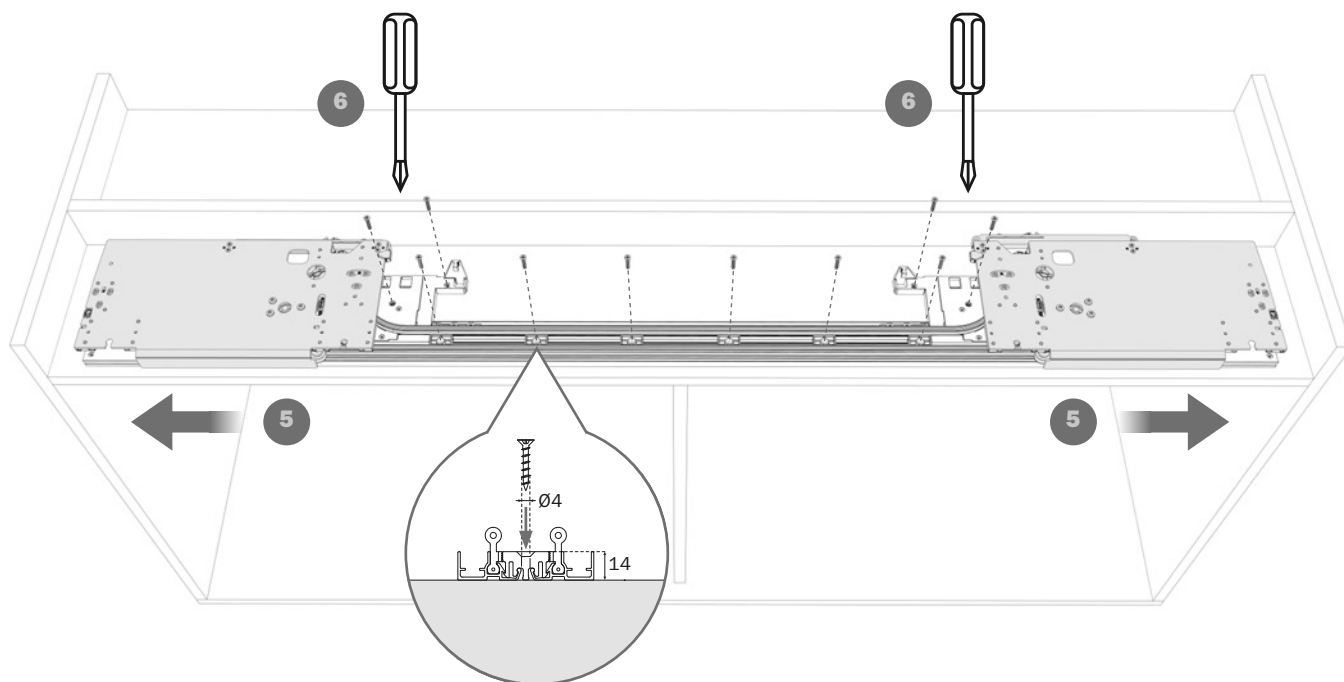
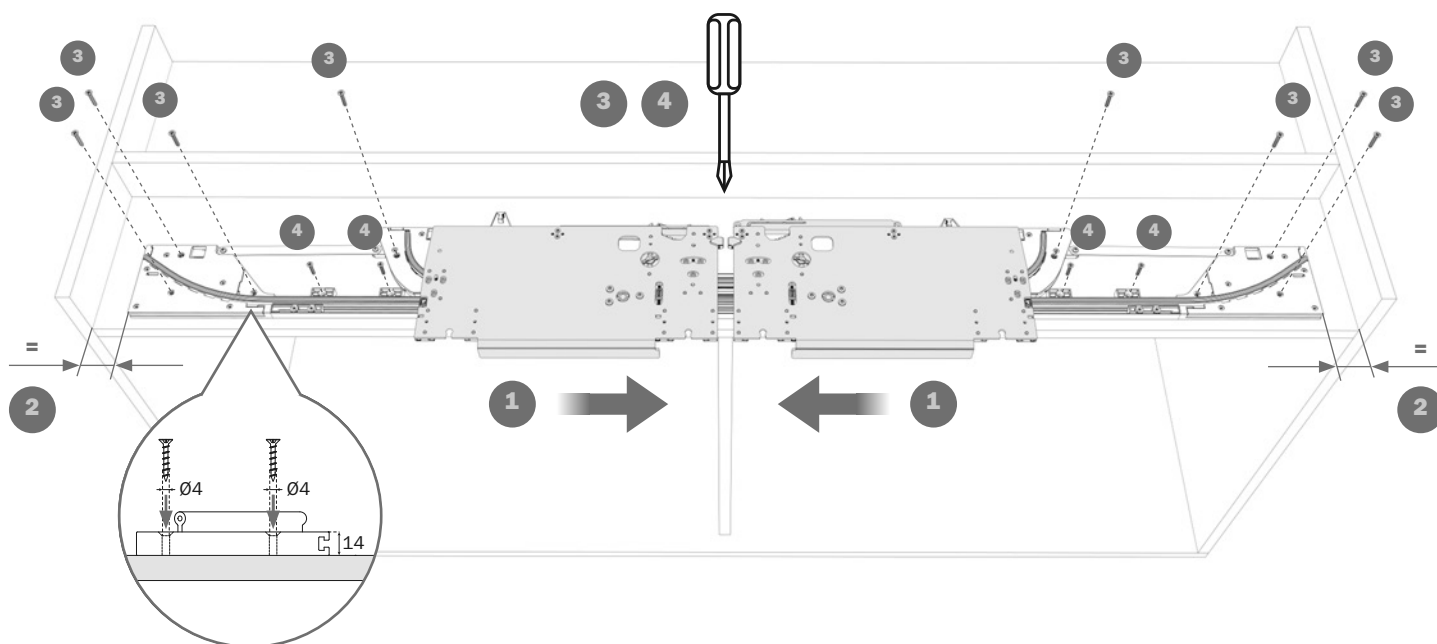

[ITA] MONTAGGIO DEL MECCANISMO SUPERIORE SULLA STRUTTURA

[ENG] INSTALLING THE UPPER MECHANISM ONTO THE CABINET

[FRA] MONTAGE DU MÉCANISME HAUT SUR LE MEUBLE

[DEU] MONTAGE DES OBEREN MECHANISMUS AM KORPUS

[ESP] MONTAJE DEL MECANISMO SUPERIOR EN LA ESTRUCTURA

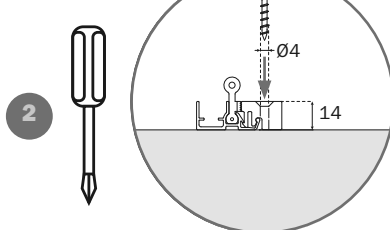
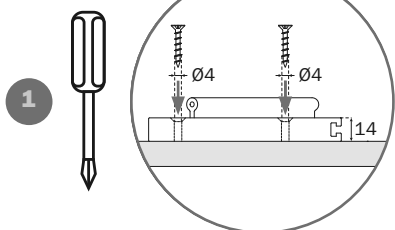
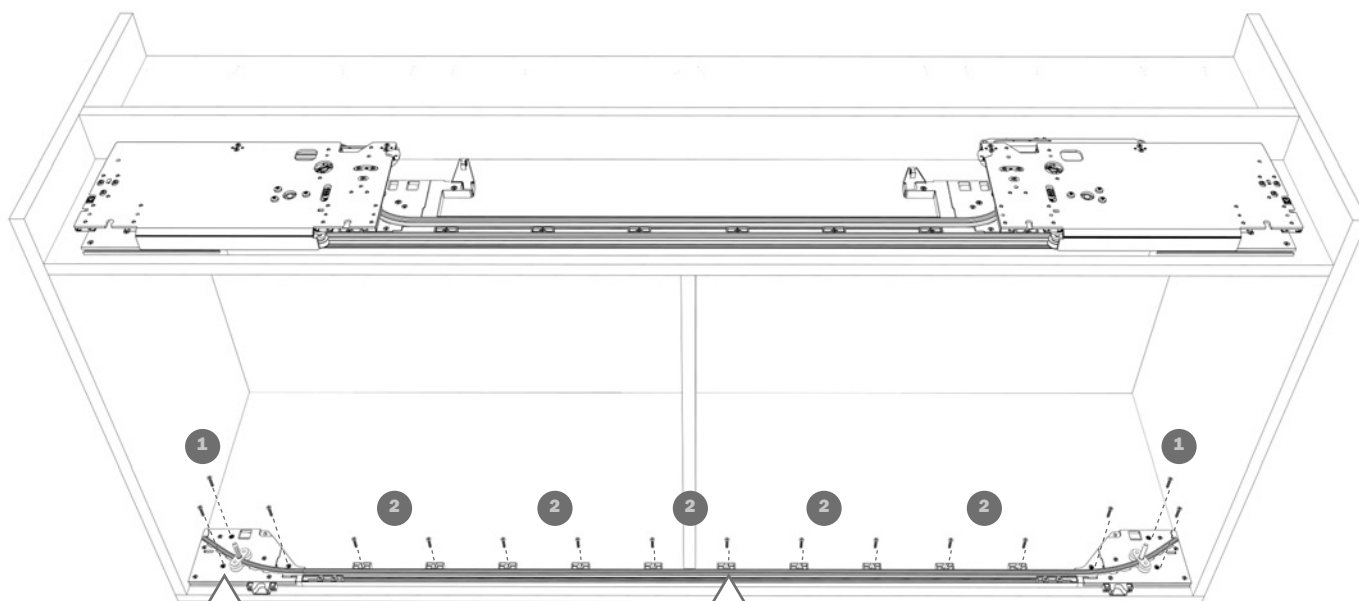
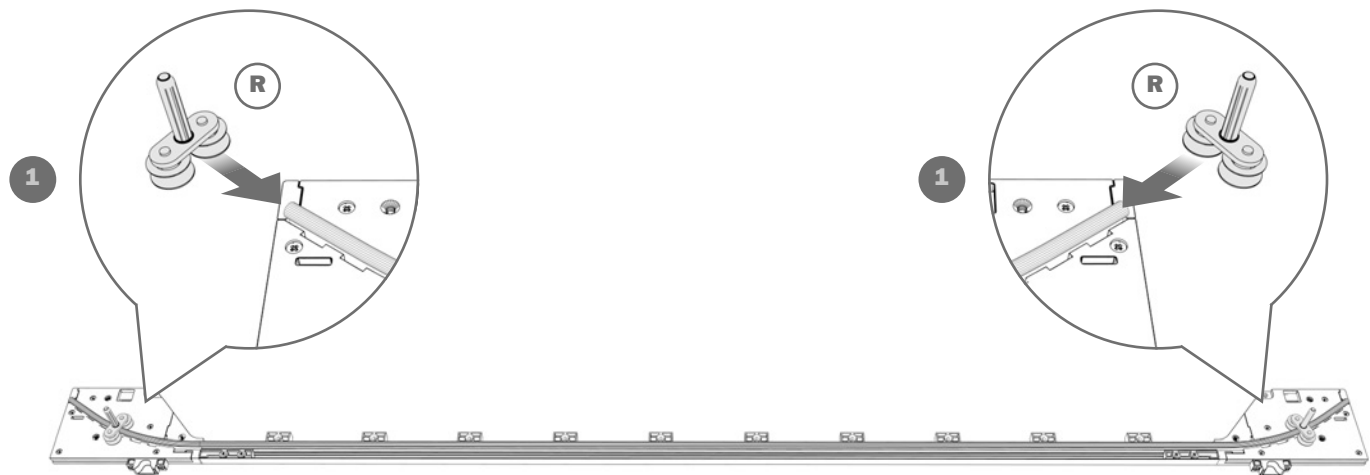

Slider S10

[ITA] PREPARAZIONE DELLE ANTE

[ENG] DOOR PREPARATION

[FRA] PRÉPARATION DES PORTES

[DEU] VORBEREITUNG DER TÜREN

[ESP] PREPARACIÓN DE LAS PUERTAS

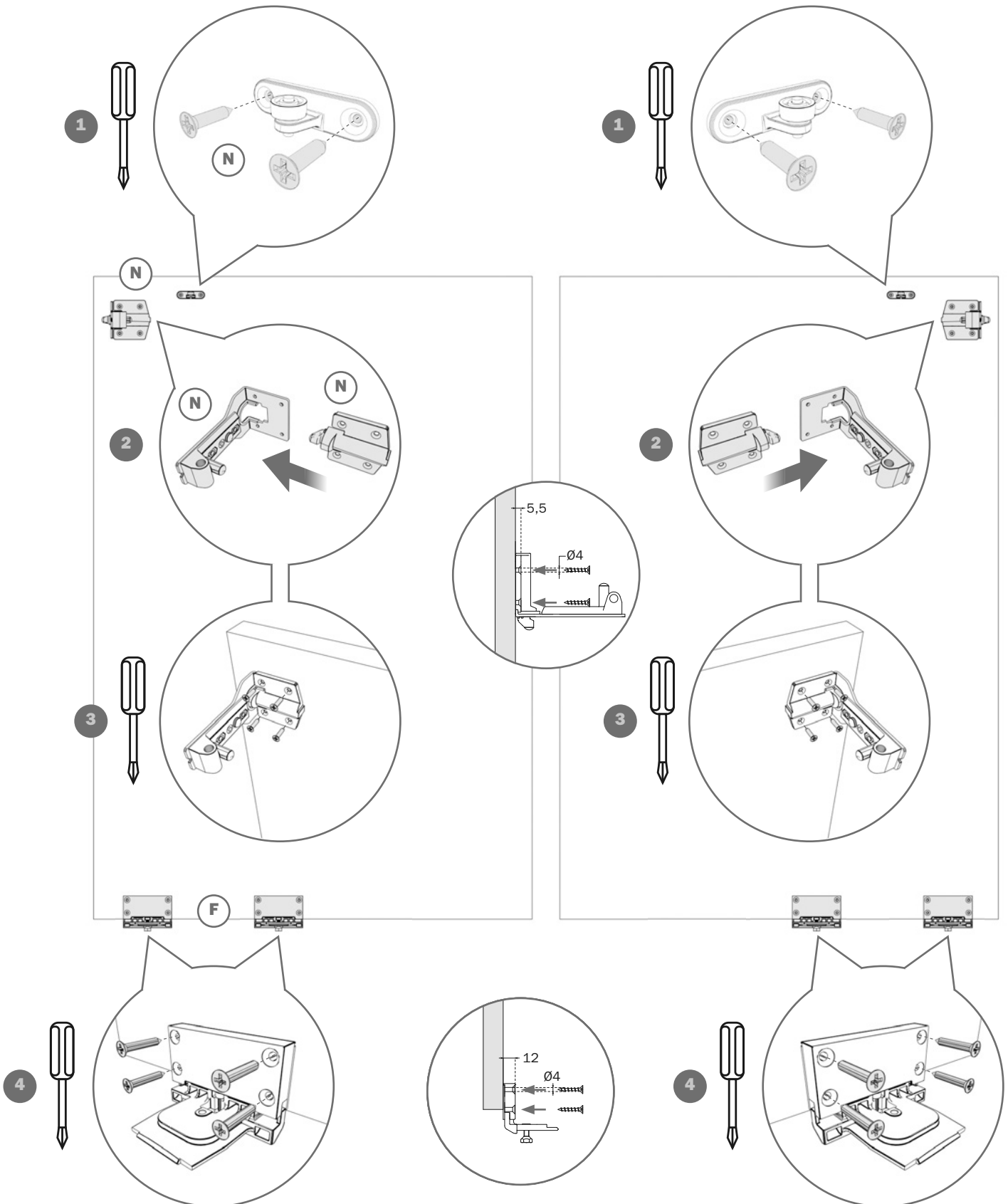

[ITA] **ELEMENTO STABILIZZATORE**
Non utilizzare in questa fase.

[ENG] **STABILISER ELEMENT**
Do not use at this stage.

[FRA] **STABILISATEUR**
Ne pas utiliser à cette étape .

[DEU] **STABILISIERUNGSELEMENT**
In dieser Phase nicht verwenden.

[ESP] **ELEMENTO ESTABILIZADOR**
No usar en esta fase.

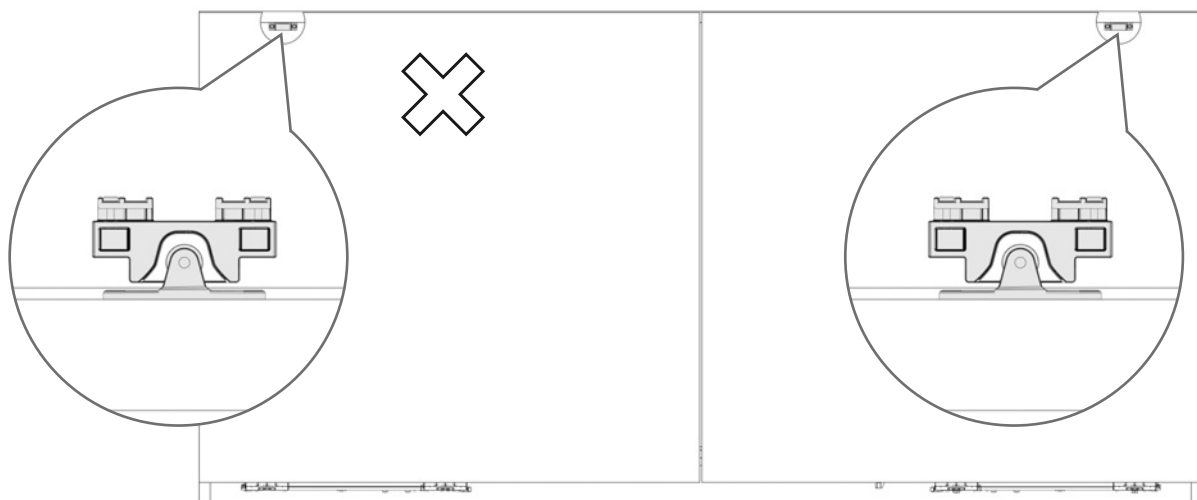
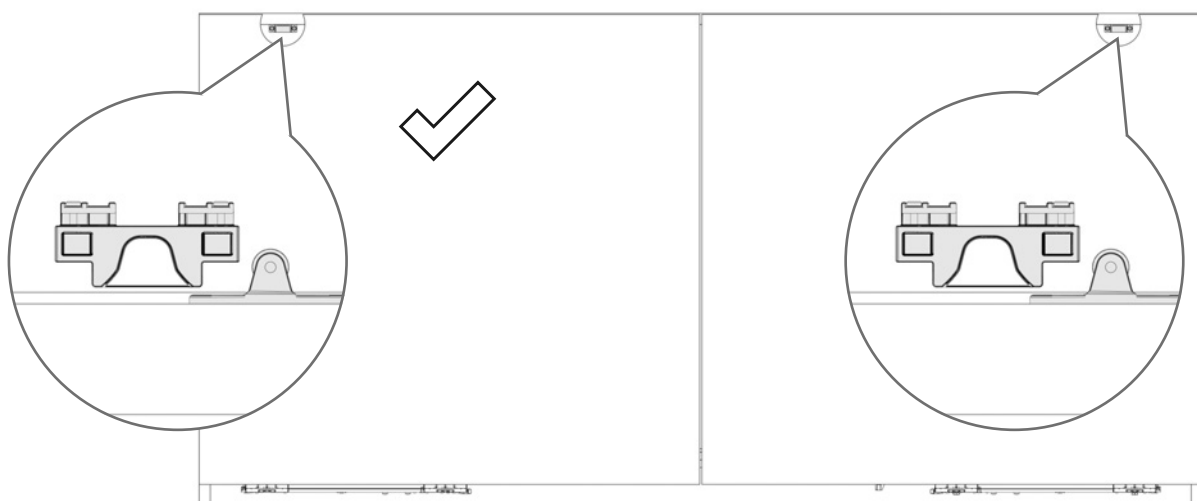

Slider S10

[ITA] **MESSA IN BOLLA DEL MOBILE**

[ENG] **UNIT LEVELLING**

[FRA] **MISE À NIVEAU DU MEUBLE**

[DEU] **MÖBEL AUSRICHTEN**

[ESP] **NIVELACIÓN DEL MUEBLE**



[ITA] **MONTAGGIO DELL'ANTA SINISTRA**

[ENG] **ASSEMBLY OF THE LEFT DOOR**

[FRA] **MONTAGE DE LA PORTE GAUCHE**

[DEU] **MONTAGE DES LINKEN TÜRFLÜGELS**

[ESP] **MONTAJE DE LA PUERTA IZQUIERDA**

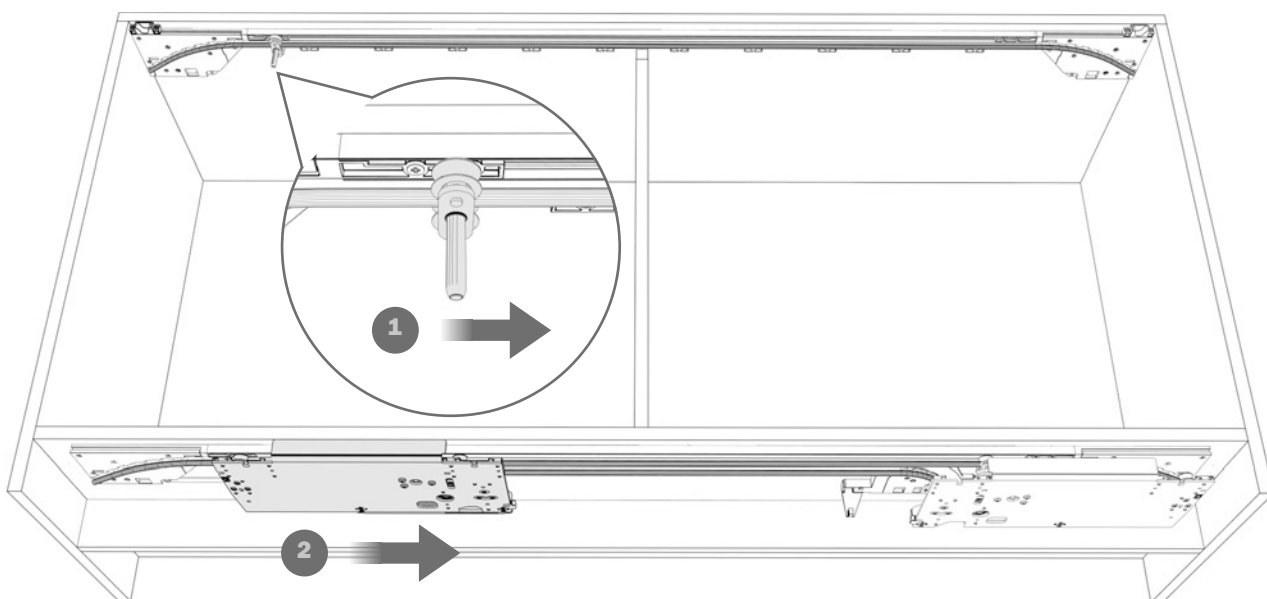

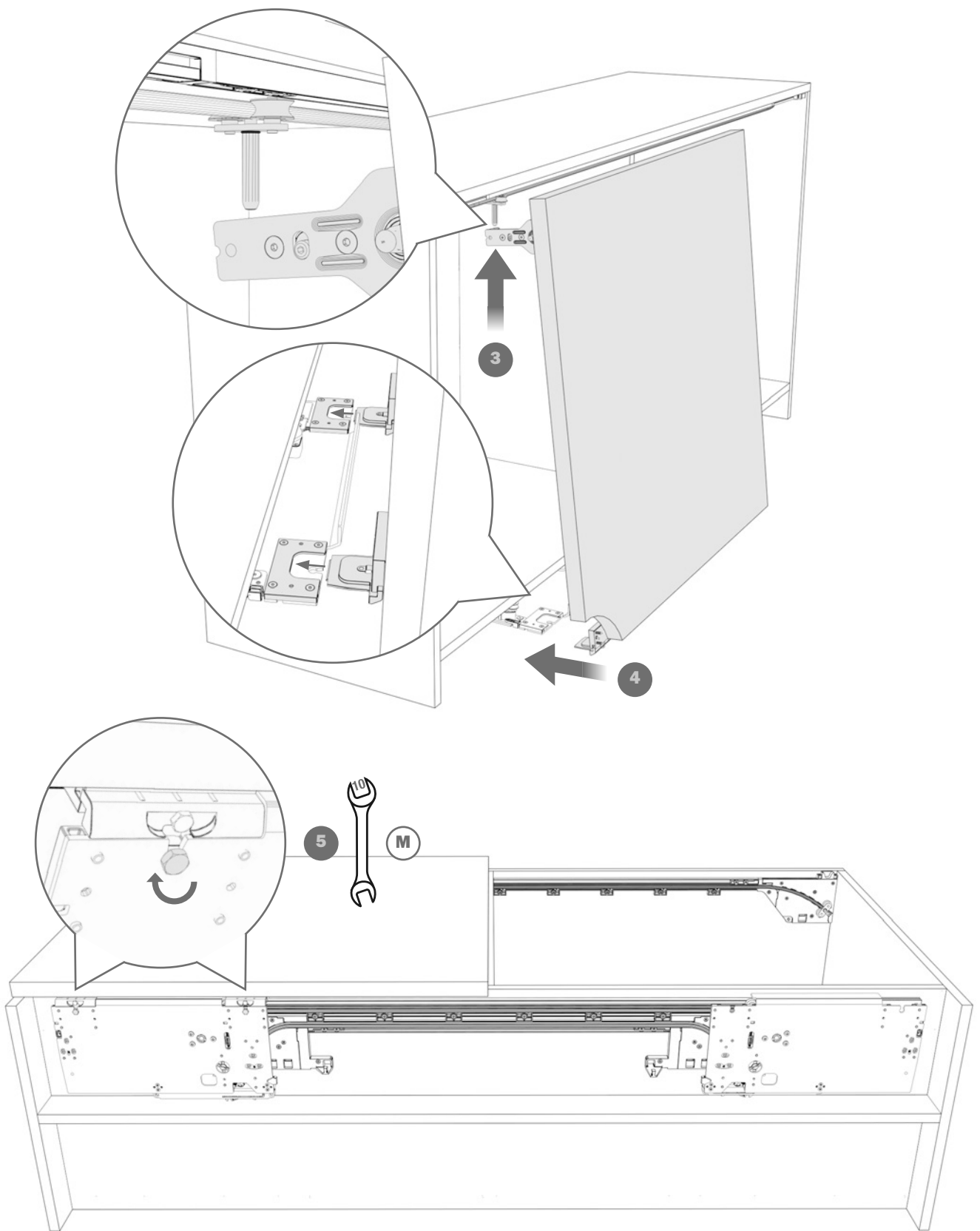

[ITA] **MONTAGGIO DELL'ANTA DESTRA**
Ripetere la sequenza delle operazioni da **1** a **5**.

[ENG] **MOUNTING THE RIGHT DOOR**
Repeat the steps from **1** to **5**.

[FRA] **MONTAGE DE LA PORTE DROITE**
Répéter les étapes des opérations de **1** à **5**.

[DEU] **MONTAGE DES RECHTEN TÜRLÜGELS**
Die Abfolge der Tätigkeiten von **1** bis **5** wiederholen.

[ESP] **MONTAJE DE LA PUERTA DERECHA**
Repeter la secuencia de las operaciones desde la **1** has la **5**.

Slider S10

[ITA] REGOLAZIONE DEL PARALLELISMO E
REGOLAZIONE VERTICALE DELL'ANTA

[ENG] HORIZONTAL ADJUSTMENT AND
VERTICAL ADJUSTMENT OF THE DOOR

[FRA] RÉGLAGE DU PARALLÉLISME ET
RÉGLAGE VERTICAL DE LA PORTE

[DEU] PARALLELE AUSRICHTUNG UND
VERTIKALE EINSTELLUNG DER TÜR

[ESP] REGULACIÓN DEL PARALELISMO Y
REGULACIÓN VERTICAL DE LA PUERTA

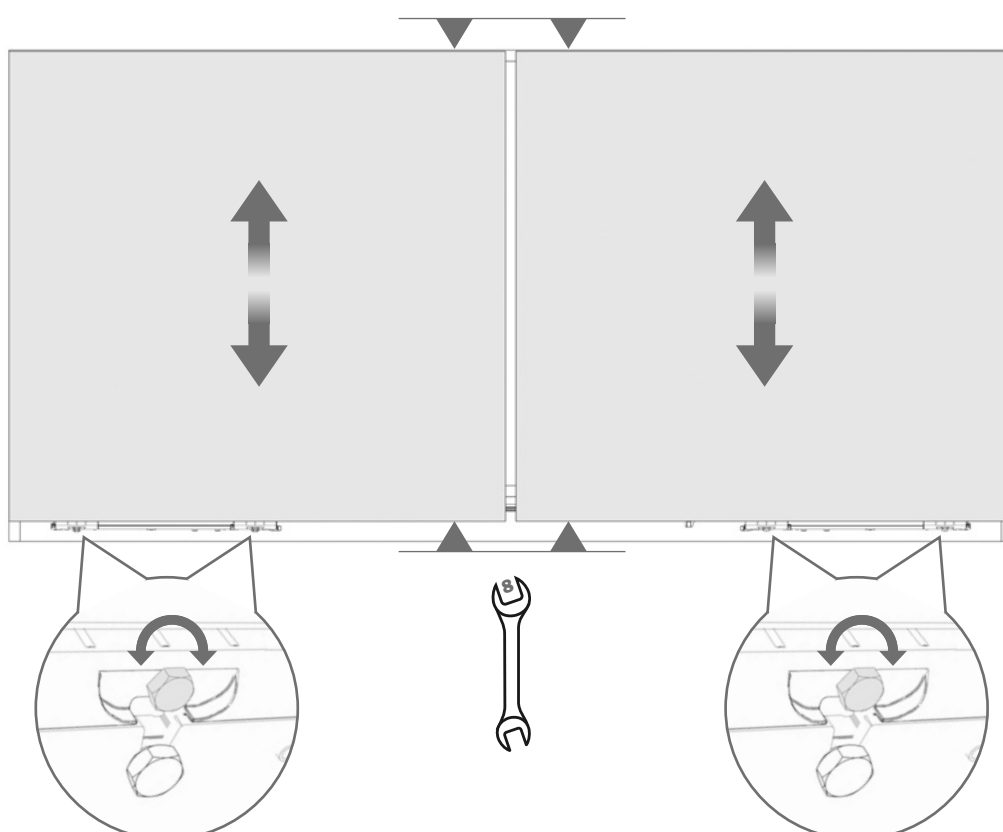
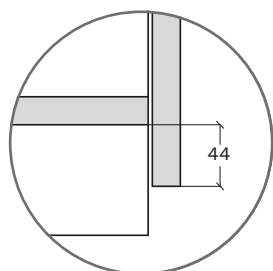
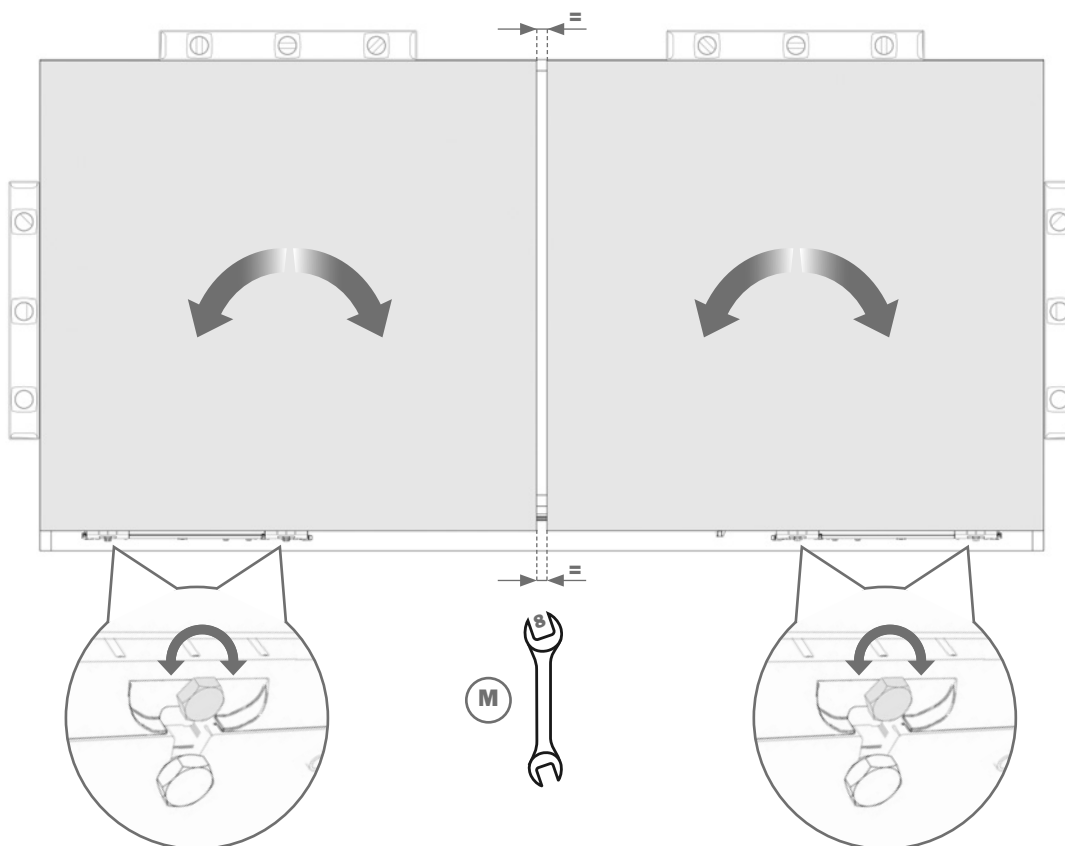

[ITA] **REGOLAZIONE ORIZZONTALE
DELL'ANTA**

[ENG] **HORIZONTAL ADJUSTMENT OF
THE DOOR**

[FRA] **RÉGLAGE HORIZONTAL DE LA PORTE**

[DEU] **HORIZONTALE EINSTELLUNG
DER TÜR**

[ESP] **REGULACIÓN HORIZONTAL DE LA
PUERTA**

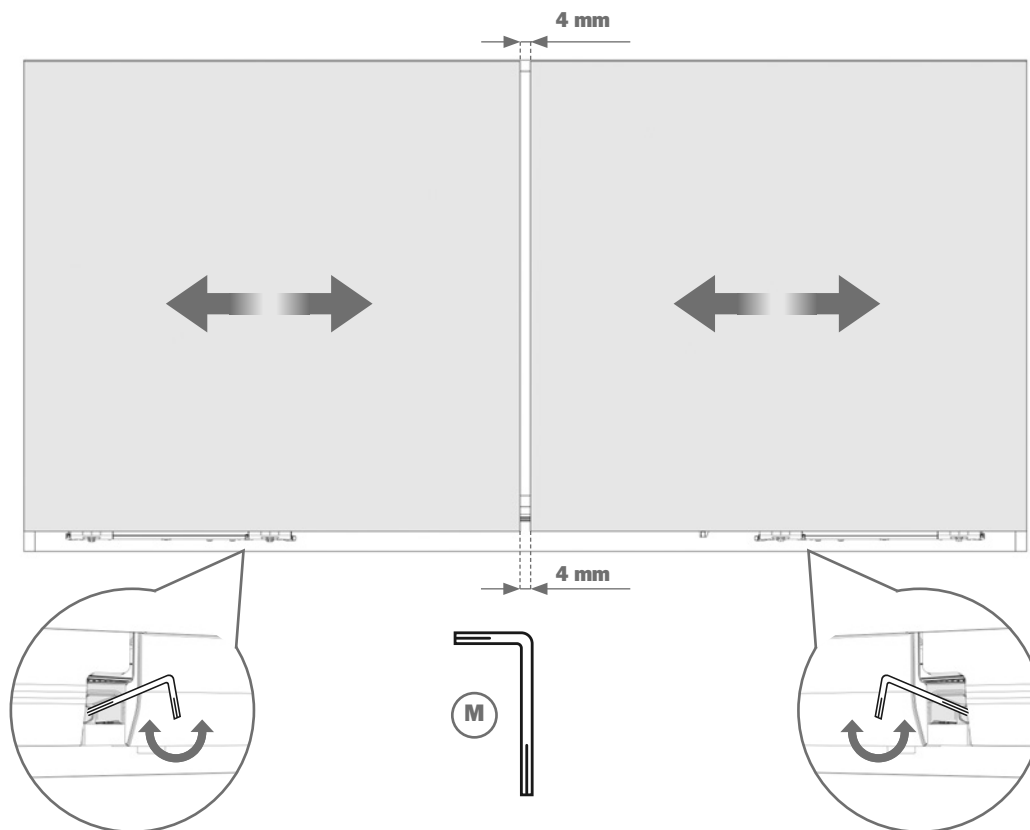

Slider S10

[ITA] REGOLAZIONE FRONTALE: SUPERIORE ED INFERIORE

[ENG] FRONT ADJUSTMENT: TOP AND BOTTOM

[FRA] RÉGLAGE FRONTAL : HAUT ET BAS

[ESP] REGULACIÓN FRONTAL: SUPERIOR E INFERIOR

[DEU] FRONTALE REGULIERUNG: OBEN UND UNTEN

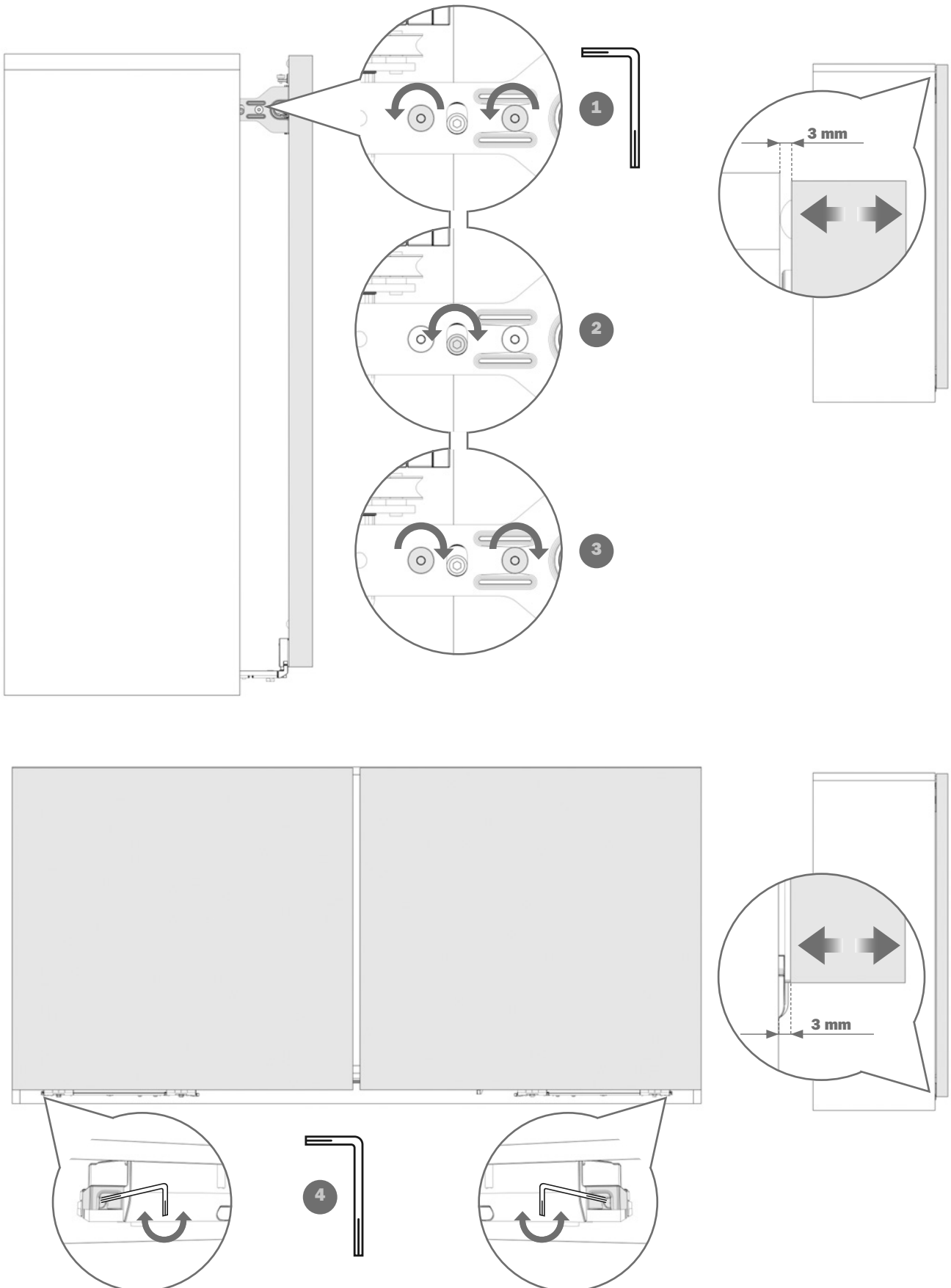

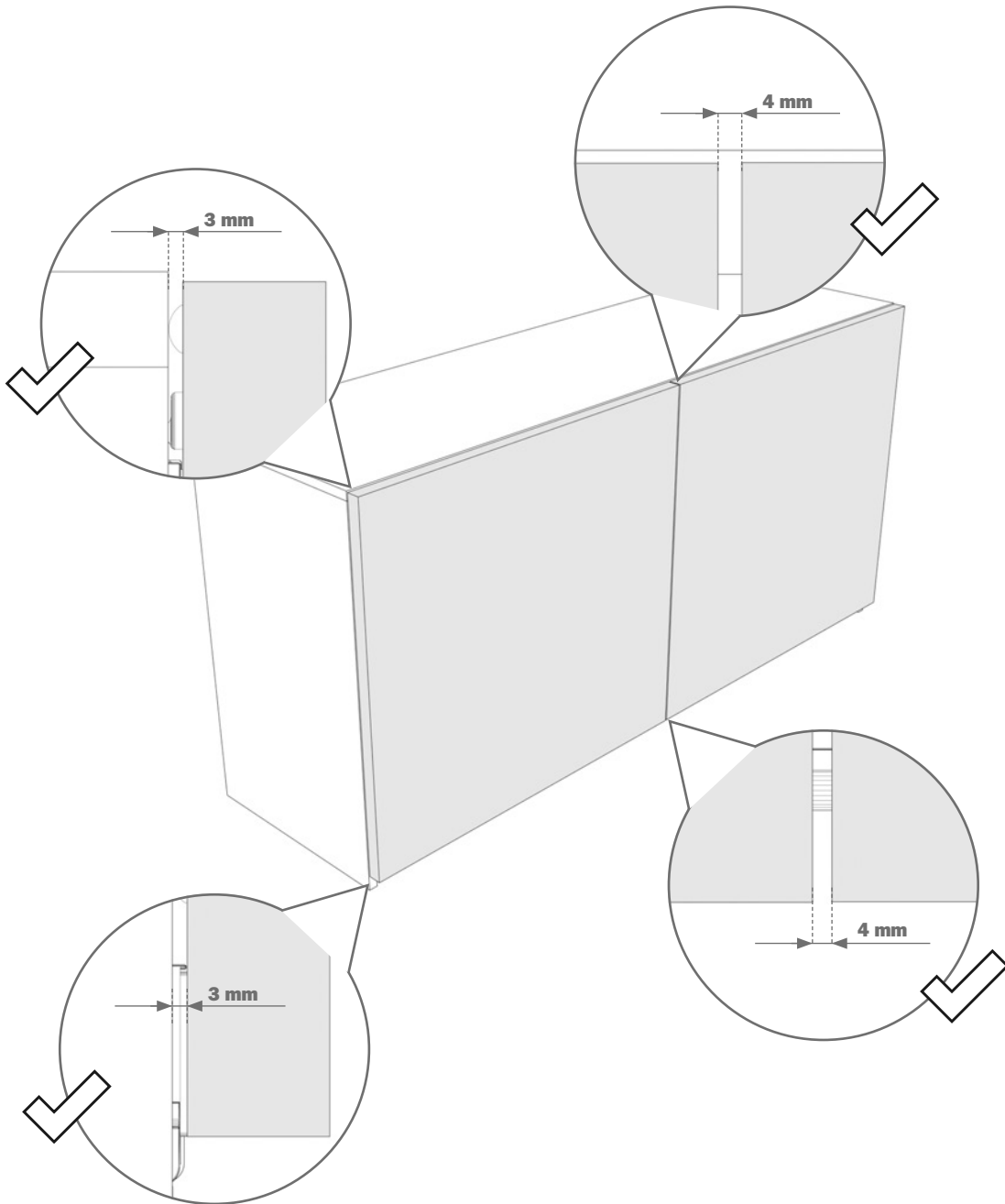

Slider S10

[ITA] REGOLAZIONE DELL'ELEMENTO DI STABILITÀ

[ENG] ADJUSTMENT OF THE STABILISER

[FRA] RÉGLAGE DU STABILISATEUR

[DEU] EINSTELLUNG DES STABILISIERUNGSELEMENT

[ESP] REGULACIÓN DEL ELEMENTO DE ESTABILIDAD

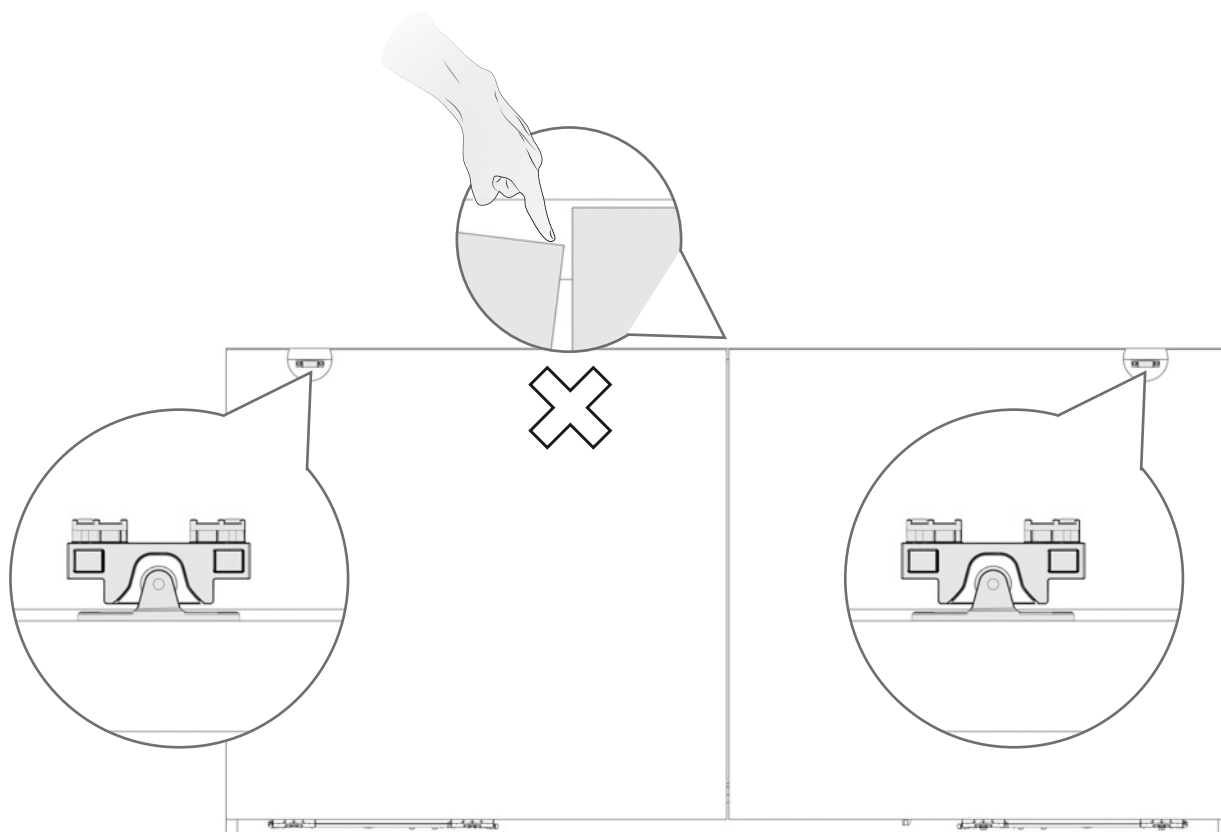
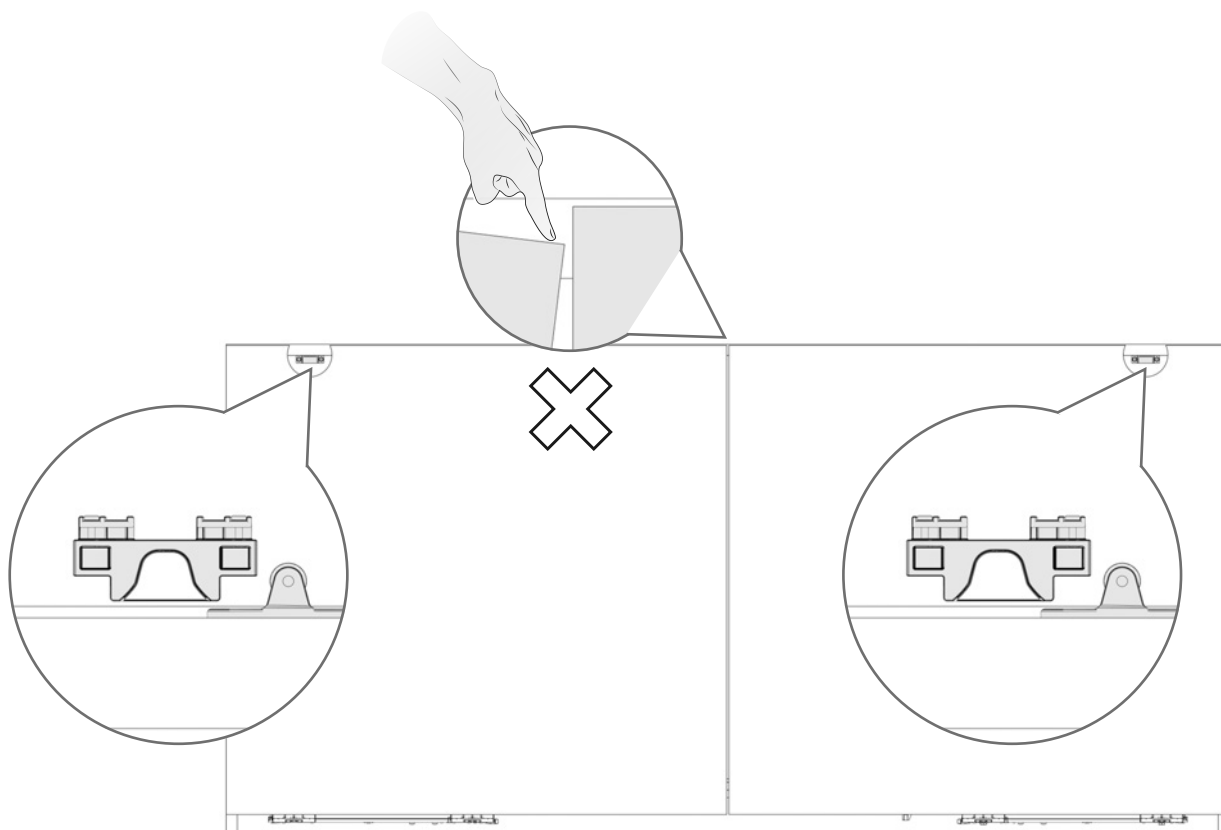

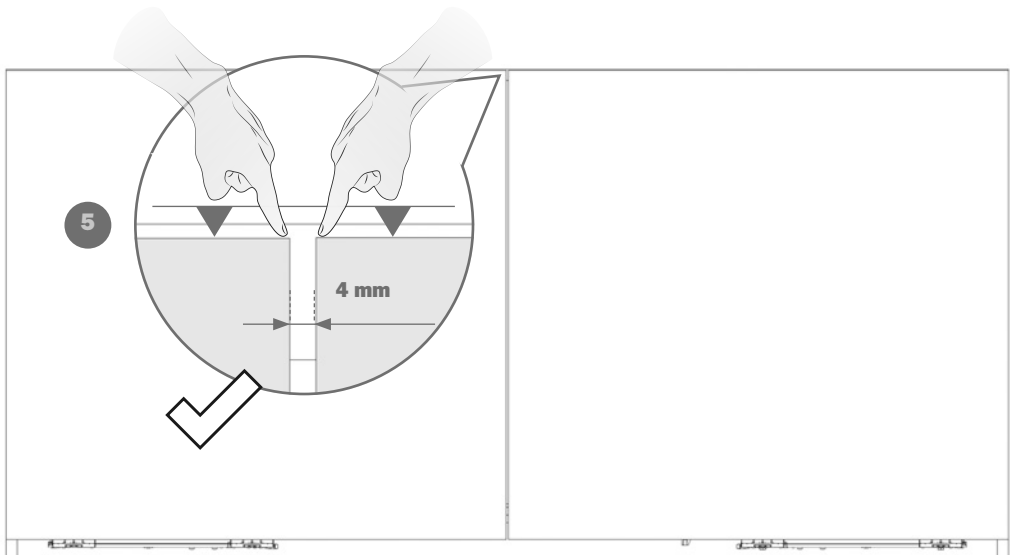
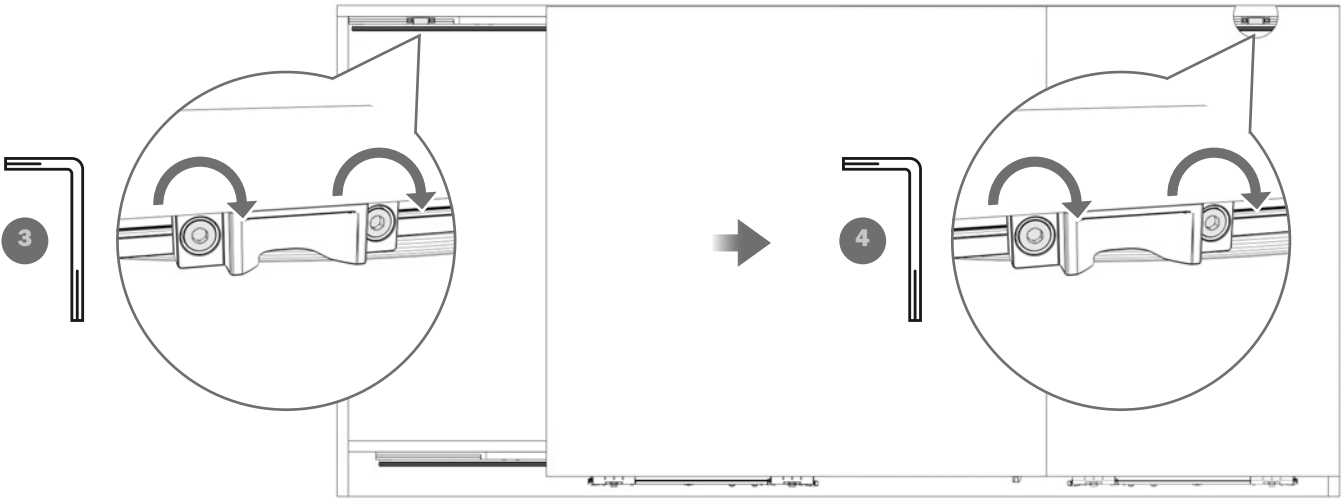
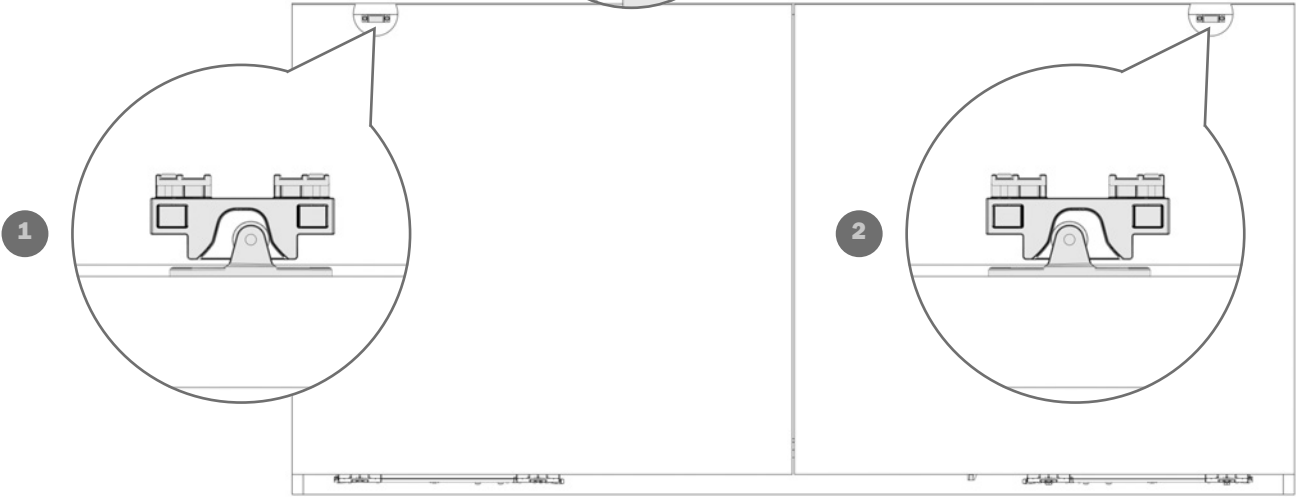
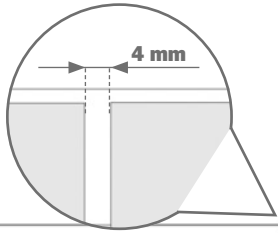

Slider S10

[ITA] REGOLAZIONE DELLA VELOCITÀ DI CHIUSURA DELL'ANTA

[ENG] ADJUSTMENT OF THE CLOSING SPEED OF THE DOOR

[FRA] RÉGLAGE DE LA VITESSE DE FERMETURE DE LA PORTE

[DEU] VERSTELLUNG DER SCHLIESSGESCHWINDIGKEIT DER TÜR

[ESP] REGULACIÓN DE LA VELOCIDAD DE CIERRE DE LA PUERTA

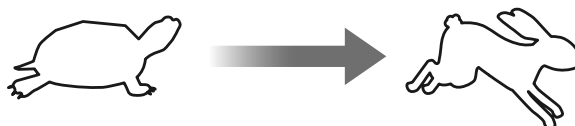
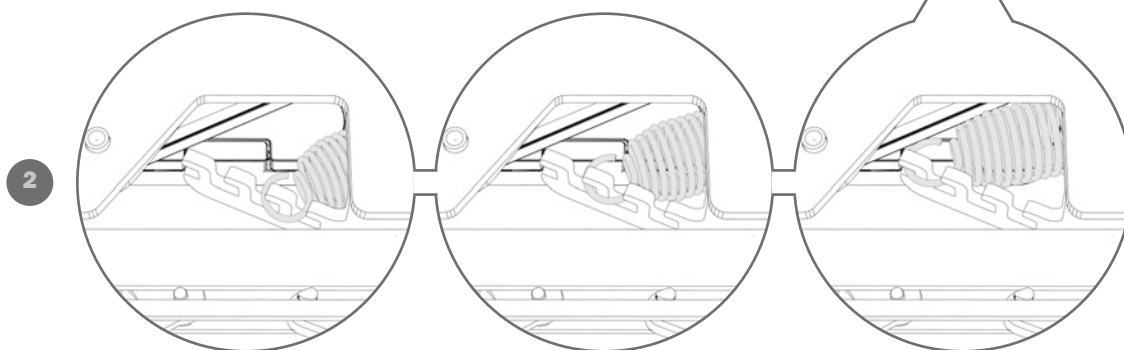
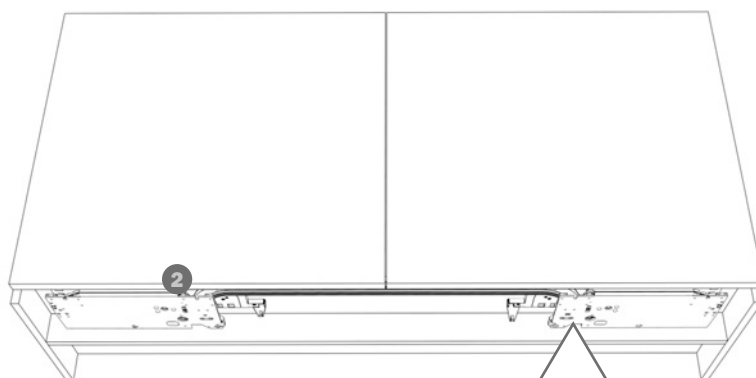
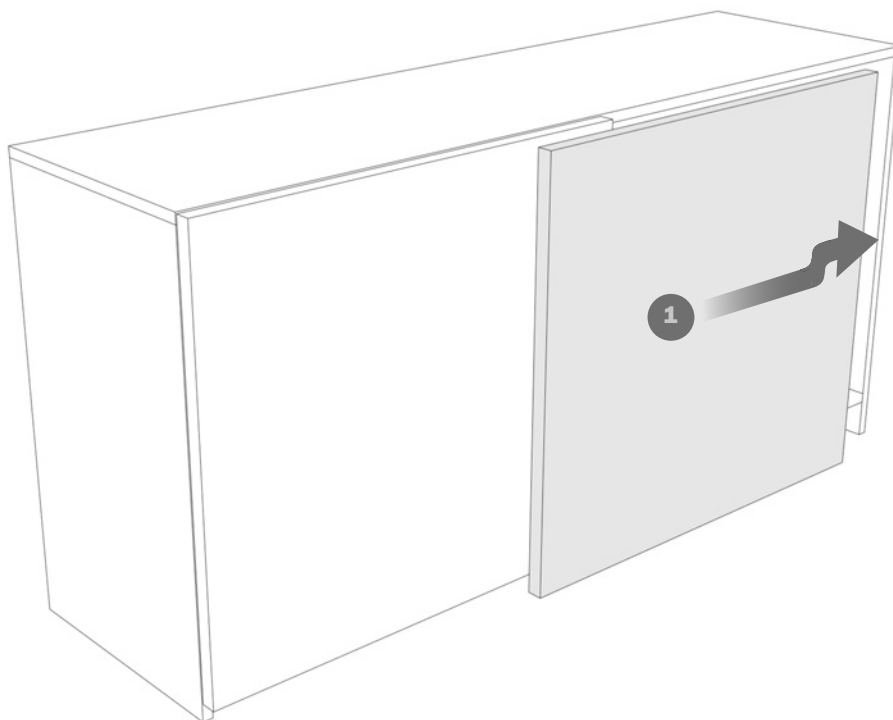

[ITA] **APPLICAZIONE DEI CARTER AI BRACCETTI SUPERIORI**

[ENG] **APPLICATION OF THE COVERS ON THE TOP ARMS**

[FRA] **MISE EN PLACE DES CACHES SUR LES PATTES DE FIXATION HAUTES**

[DEU] **ANBRINGUNG DER ABDECKUNGEN AN DEN OBEREN HALTERUNGEN**

[ESP] **APLICACIÓN DE LOS CÁRTERES A LOS BRAZOS SUPERIORES**

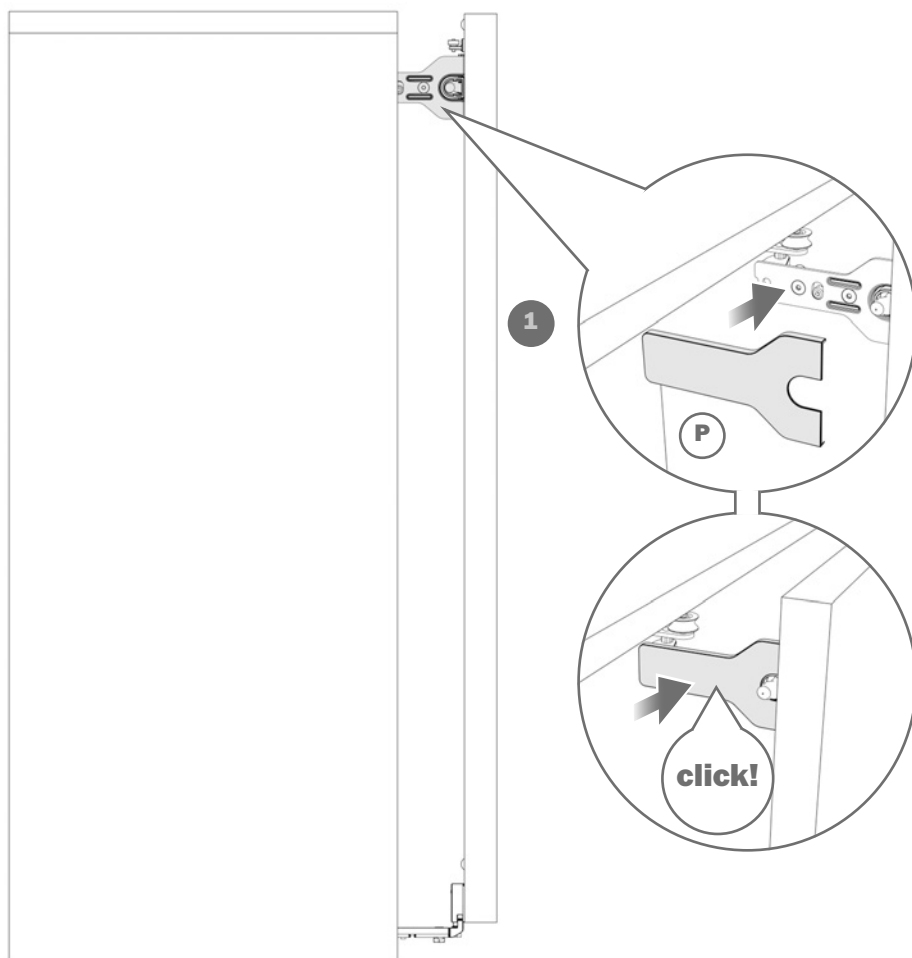

Slider S10

[ITA] **APPLICAZIONE DEI PARACOLPI**

[ENG] **APPLICATION OF BUMPER**

[FRA] **MISE EN PLACE DES BUTÉES**

[DEU] **ANBRINGUNG DER PUFFER**

[ESP] **APLICACIÓN DE LOS TOPES**

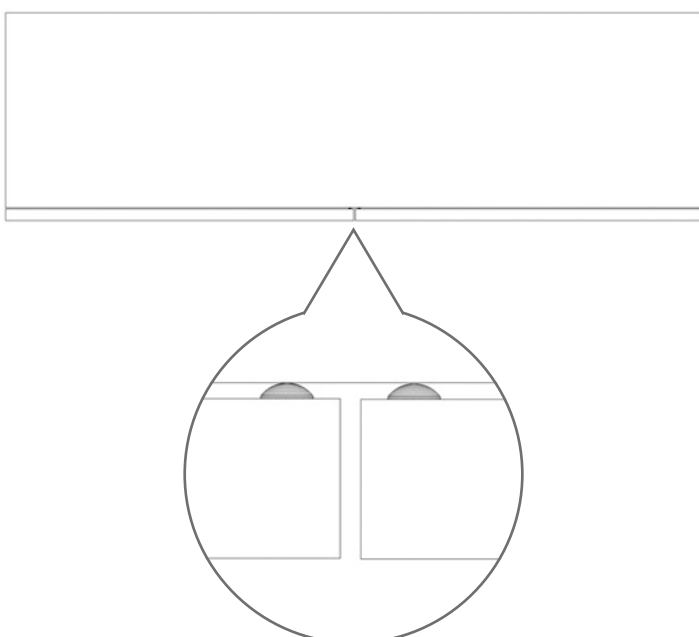
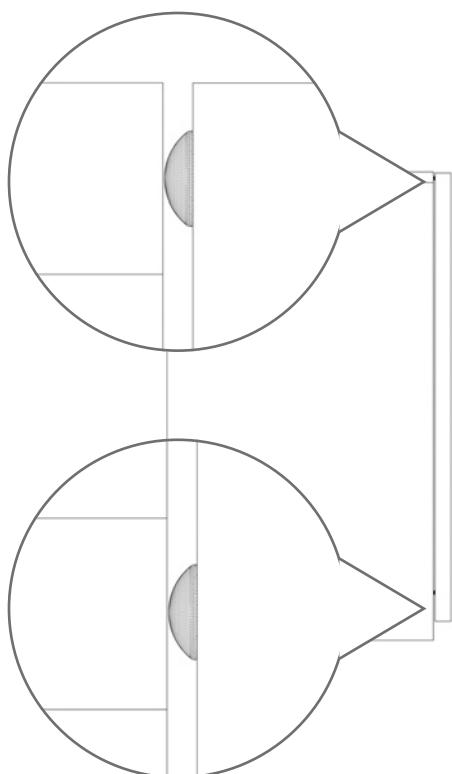
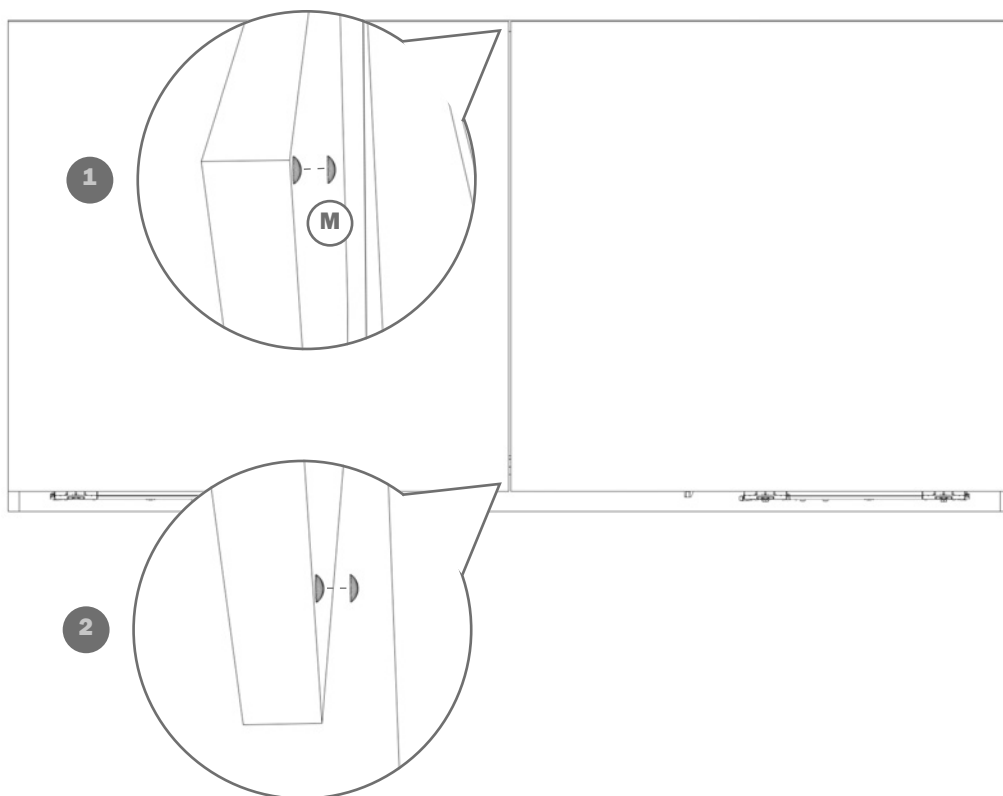

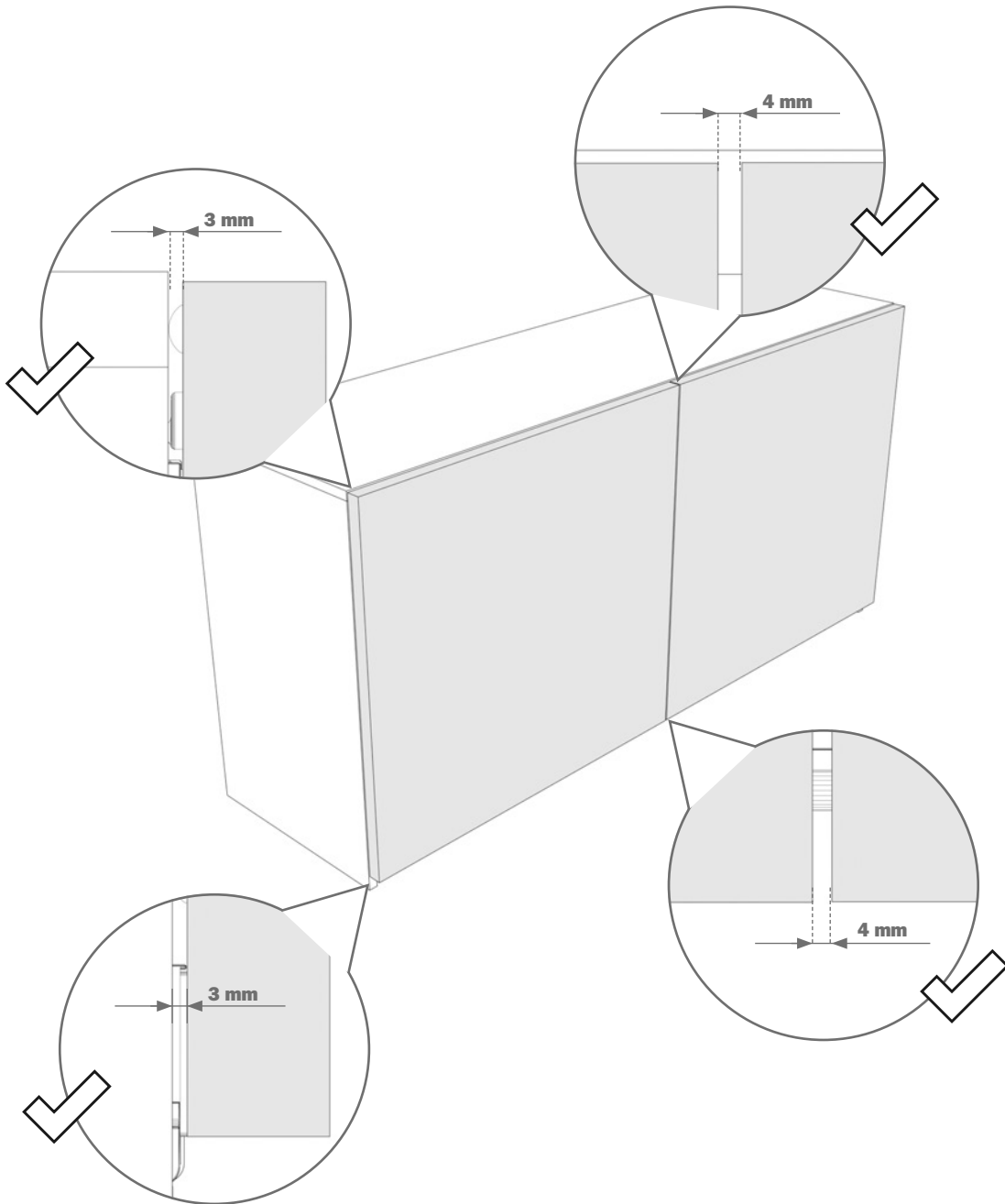

[ITA] PULIZIA

La pulizia dei componenti deve essere eseguita con un panno morbido inumidito con acqua e sapone. Vanno evitati prodotti contenenti solventi e componenti abrasivi.

SMALTIMENTO

Una volta dismesso, il prodotto e i suoi componenti non vanno dispersi nell'ambiente, ma conferiti ai sistemi pubblici di smaltimento.

NOTA

Salice si riserva il diritto di apportare modifiche tecniche senza preavviso.

[ENG] CLEANING

The components must be cleaned using a soft cloth with soap and water. Avoid using products containing solvents and abrasive products.

DISPOSAL

The product and its components must not be disposed of in the environment; for disposal, please use public disposal systems.

NOTE

Salice reserves the right to modify any product without prior notice.

[FRA] NETTOYAGE

Le nettoyage des composants doit être effectué avec un chiffon doux imbibé d'eau et de savon. Il faut éviter les produits contenant des solvants et des composants abrasifs.

ÉLIMINATION

Une fois jeté, le produit et ses composants ne peuvent pas être dispersés dans l'environnement naturel mais confiés au service public de gestion des déchets.

REMARQUE

Salice se réserve le droit d'apporter des modifications techniques sans préavis.

[DEU] REINIGUNG

Die Reinigung der Bauteile wird mit einem mit Wasser und Seife befeuchteten, weichen Tuch ausgeführt.

ENTSORGUNG

Die Produkte und die Produktteile, die nicht mehr eingesetzt werden, sollen nicht in die Umwelt gelangen, sondern an den geeigneten Stellen entsorgt werden.

HINWEIS

Salice behält sich das Recht vor, ohne vorherige Ankündigung technische Änderungen durchzuführen.

[ESP] LIMPIEZA

La limpieza de los componentes debe realizarse con un paño suave humedecido con agua y jabón. Hay que evitar productos que contengan disolventes y componentes abrasivos.

ELIMINACIÓN

Una vez en desuso, el producto y sus componentes no se deben echar en el medio ambiente, ya que deben entregarse a los sistemas públicos de eliminación de residuos.

NOTA

Salice se reserva el derecho de realizar modificaciones técnicas sin preaviso.

