

ATLAS SYSTEM

For large suspended low furniture

- > The perfect solution for heavy loads in suspended kitchens and bathroom cabinets.
- > Maximum safety in the vertical loads, anti-tilt, easy machining and regulation.
- > Does not interfere with the smooth running of the top drawers.
- > Easy industrial installation, can be preassembled to ease transport.
- > In combination with the lower support fitting, the furniture can be adjusted in depth, vertically and horizontally.
- > Nominal capacity of 100kgs. per hanger. EN 15939 on B setting (60kg on C setting).





MAIN ADVANTAGES OF THE PRODUCT

INDAUX has developed ATLAS fitting device, as an answer to the technical challenges that the new suspended kitchens present. Traditional furniture fixing devices are not suitable for this trend, as are designed for cabinets with little depth and without drawers.

- > Hidden wall fixing system which adjusts perfectly to the module.
- > Easy industrial installation, can be preassembled to ease transport.
- > In combination with the lower support fitting, it can be adjusted in depth, vertically and horizontally

- > The ATLAS system does not interfere with the smooth running of the top drawers.
- > Nominal capacity of 100kgs. per hanger. EN 15939 on B setting (60kg on C setting).

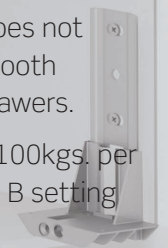

1 ATLAS

■ Back support fitting and wall plate

Back support fitting

Zinc-plated	625.700.036	50
-------------	-------------	----

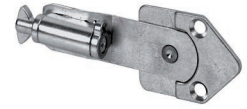
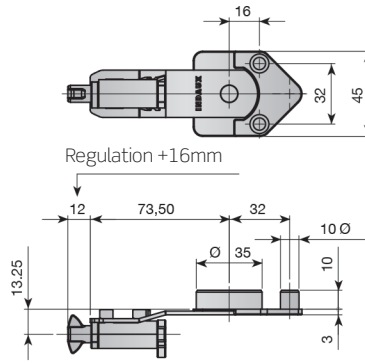

Wall plate

Zinc-plated	620.860.030	100
-------------	-------------	-----

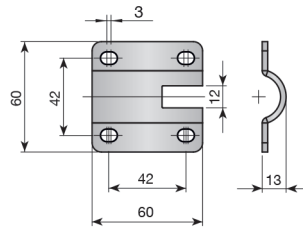

Large wall plate

Zinc-plated	620.913.031	50
-------------	-------------	----

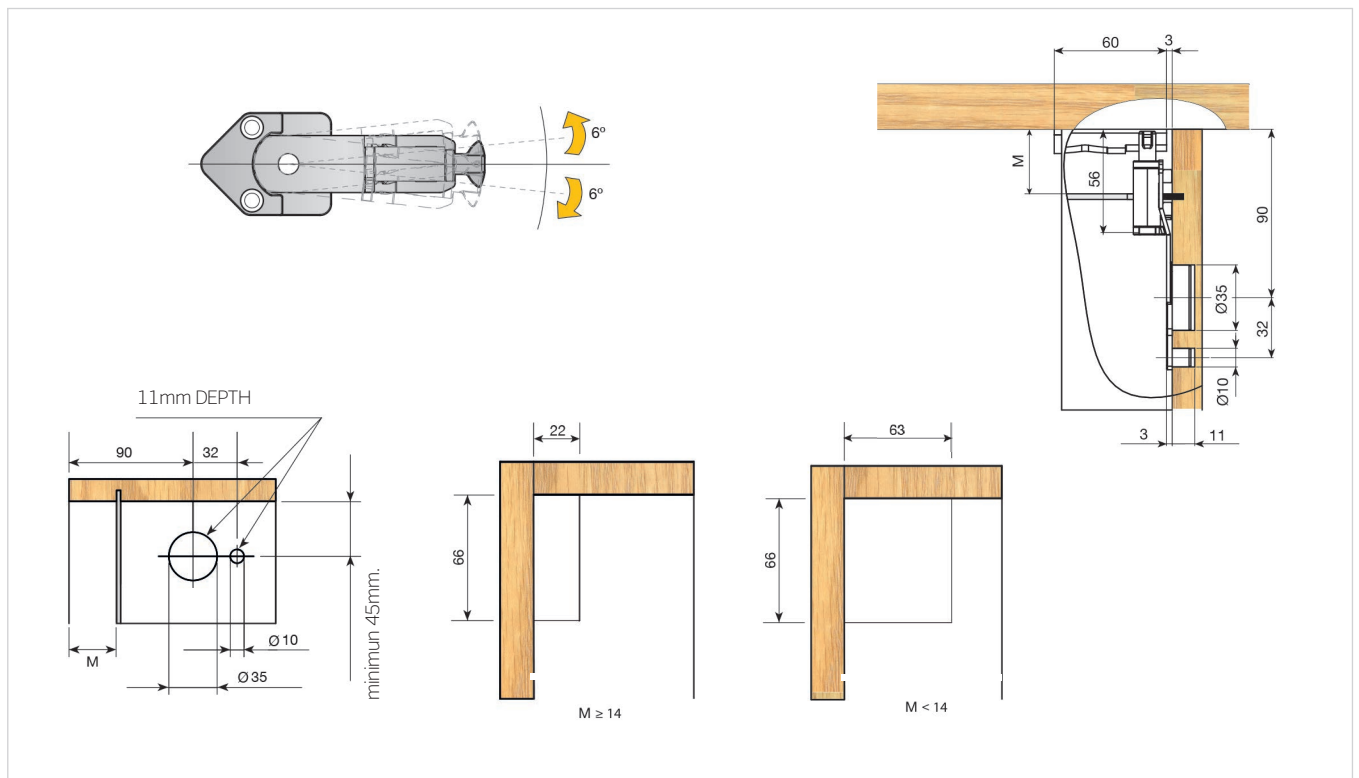
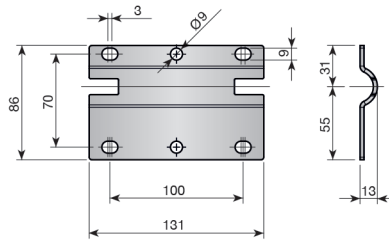

■ Lower support fitting

Lower support fitting 32mm.

Zinc-plated	625.800.033	25
-------------	-------------	----

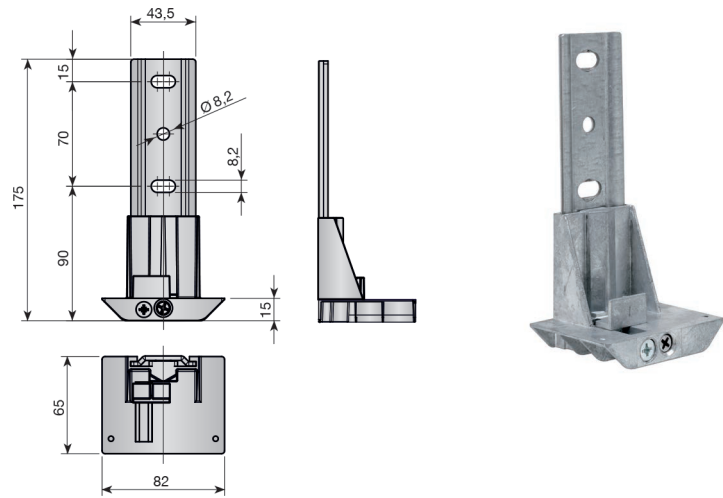

Lower support fitting 3mm.

Zinc-plated		
A - Without flange	628.000.030	25
B - Left flange	628.010.036	
C - Double flange	628.030.034	
D - Right flange	628.020.035	

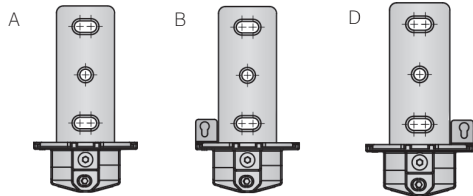
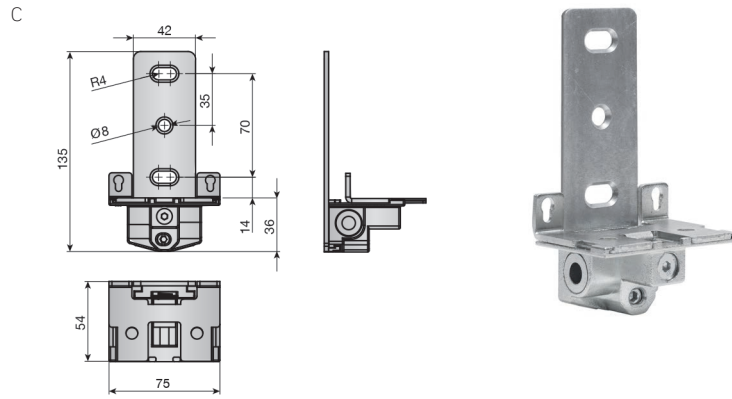

Lower support fitting 2 mm.

Zinc-plated	628.110.033	25
-------------	-------------	----

With frontal and vertical regulation.

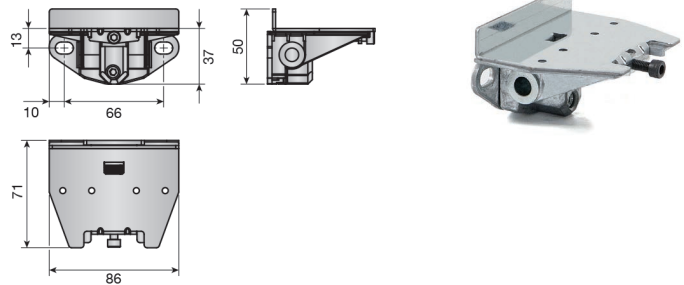

Lower support fitting 0 mm.

Zinc-plated	628.100.034	25
-------------	-------------	----

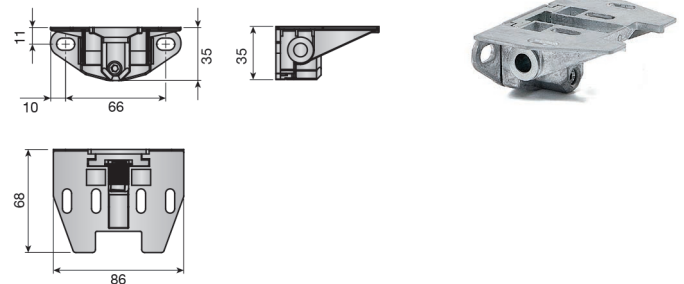

2 TECHNICAL DATA

■ Lower supports selection guide

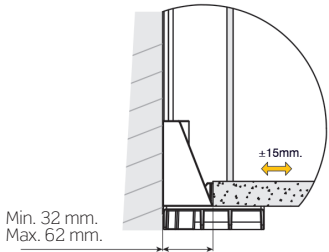
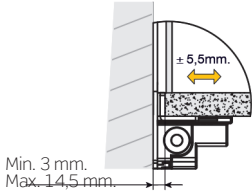
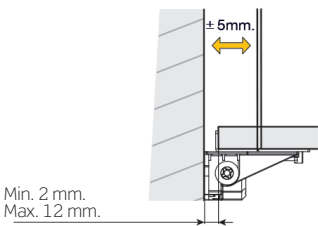
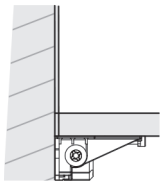
Lower support fitting		Adjustments	
		Frontal (horizontal)	Vertical
32 mm.	 <p>Min. 32 mm. Max. 62 mm.</p>	+/- 15 mm.	+/- 10 mm.
3 mm.	 <p>Min. 3 mm. Max. 14,5 mm.</p>	+/- 5,5 mm.	+/- 6 mm.
2 mm.	 <p>Min. 2 mm. Max. 12 mm.</p>	+/- 5 mm.	+/- 5 mm.
0 mm.		—	+/- 5 mm.

2 TECHNICAL DATA

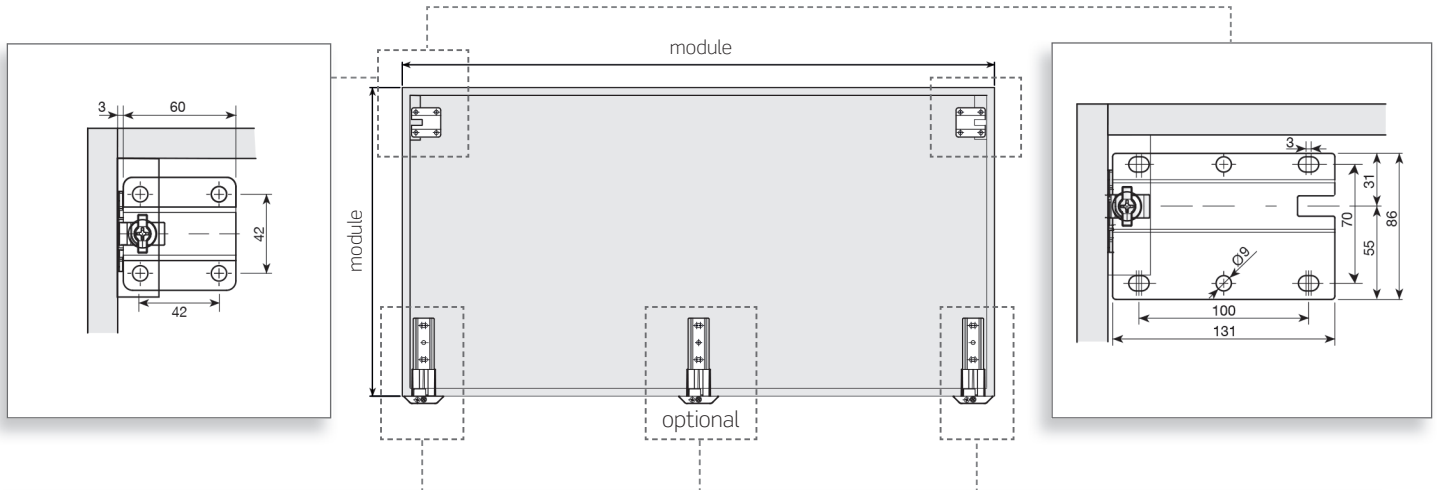

Lower support fitting 32 mm.

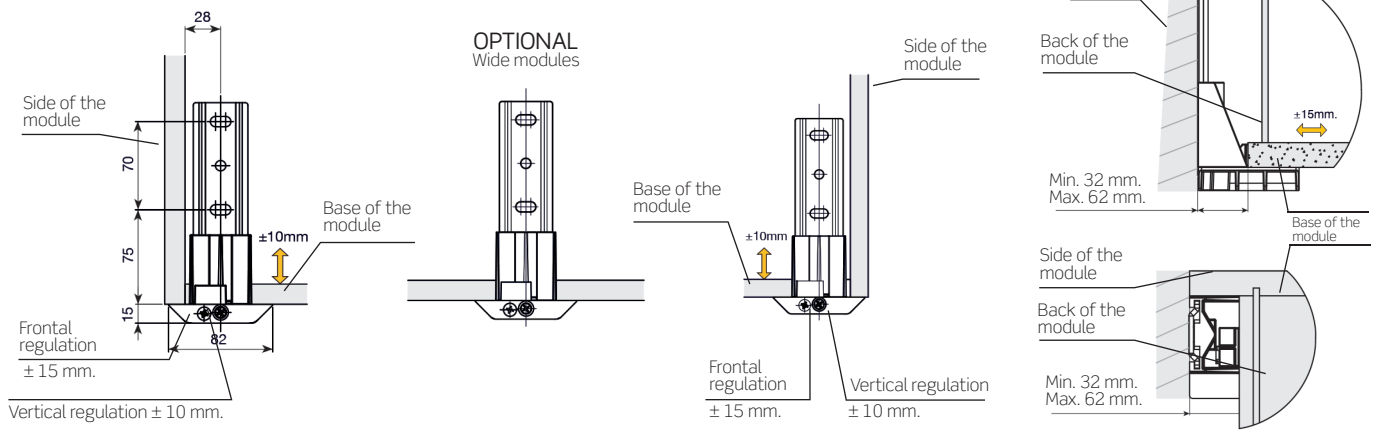

Lower support fitting 3mm.

± 15 mm.

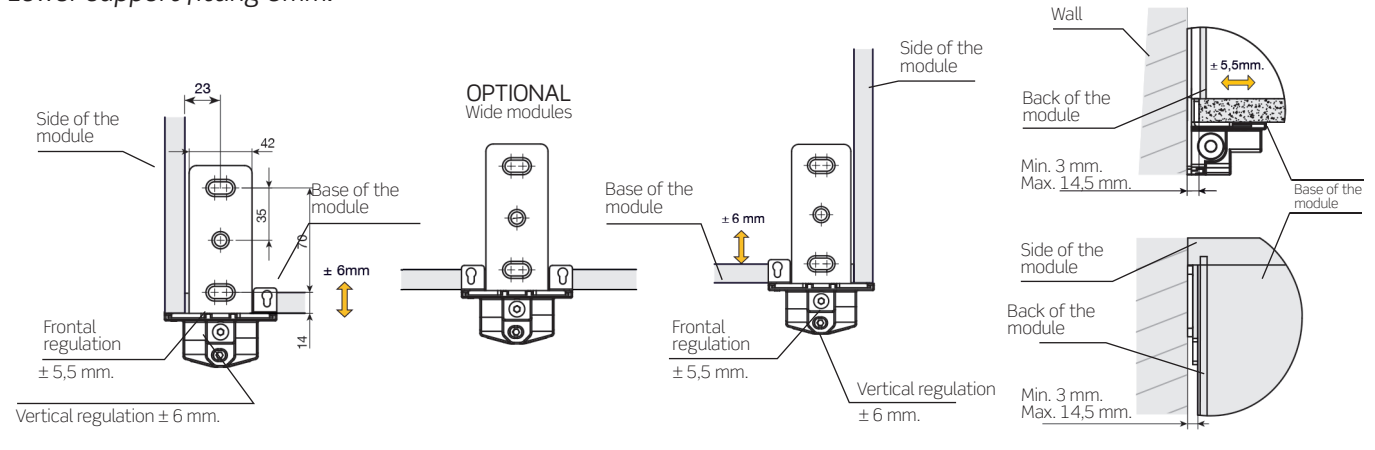

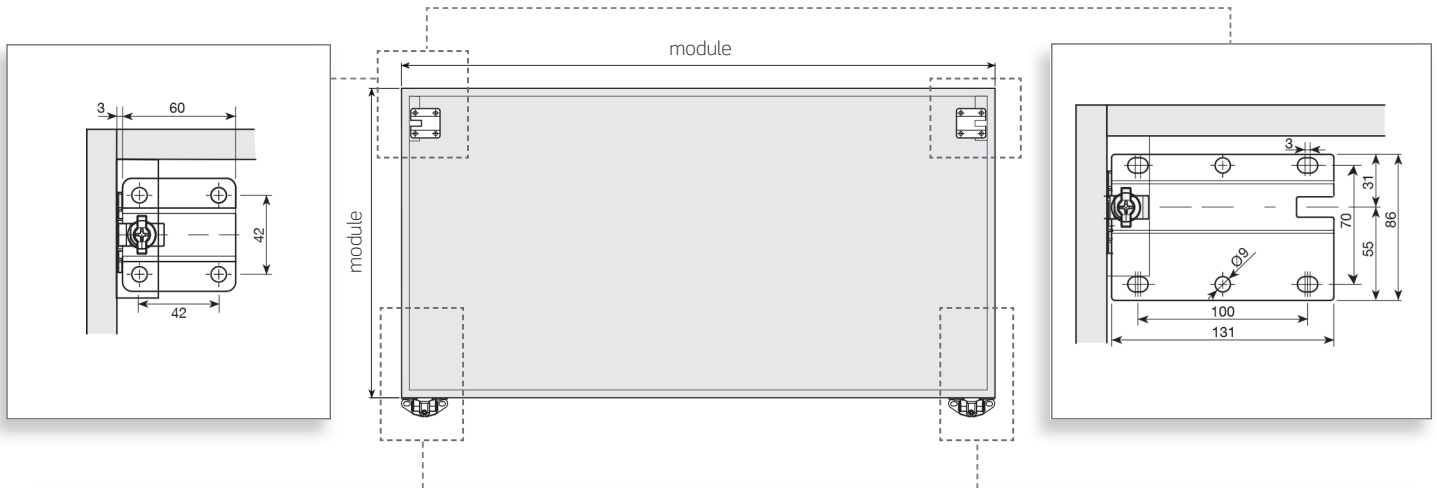

Lower support fitting 0 mm.

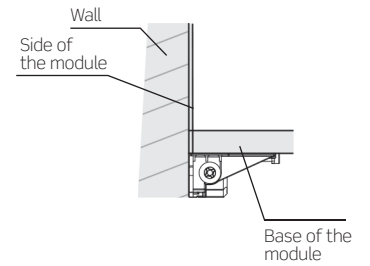
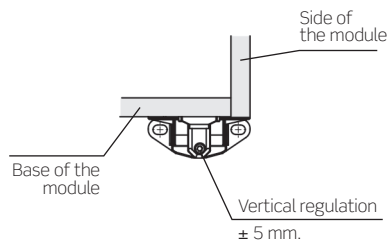
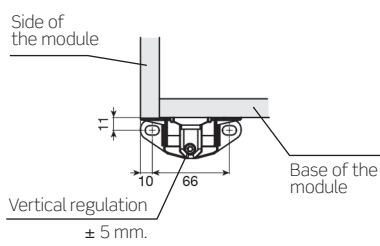

Lower support fitting 2mm.

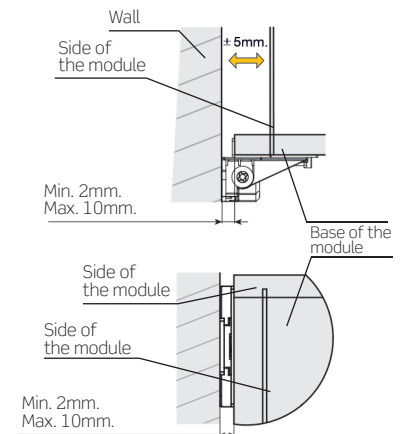
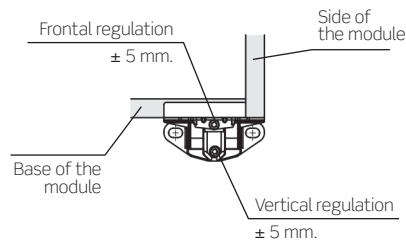
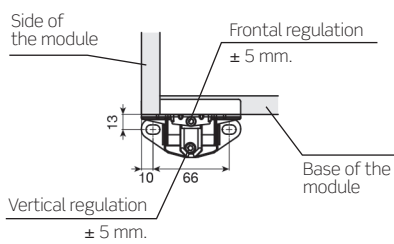

3 ASSEMBLY AND ADJUSTMENTS

Example using lower support fitting 32mm.

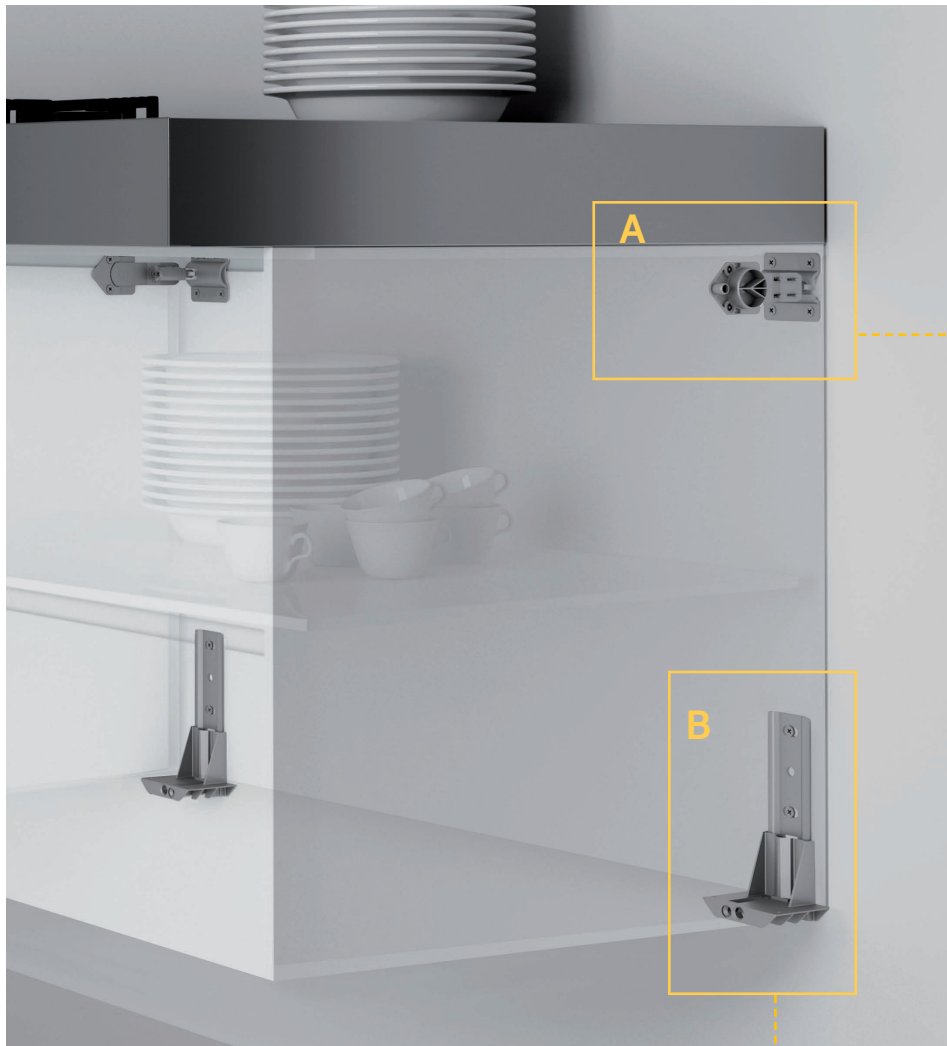

B

± 10mm

No previous machining of the module required before fixing the lower support.

A

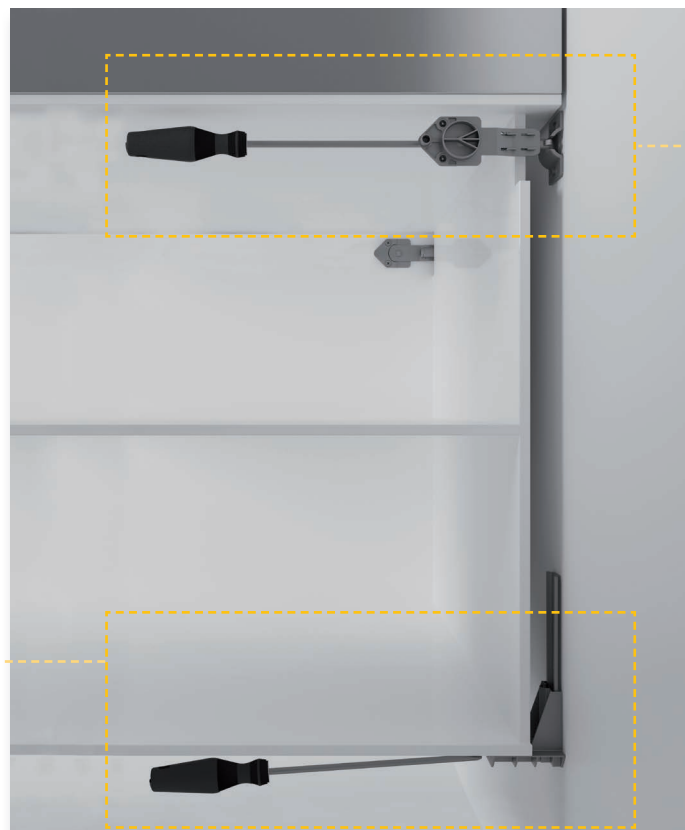
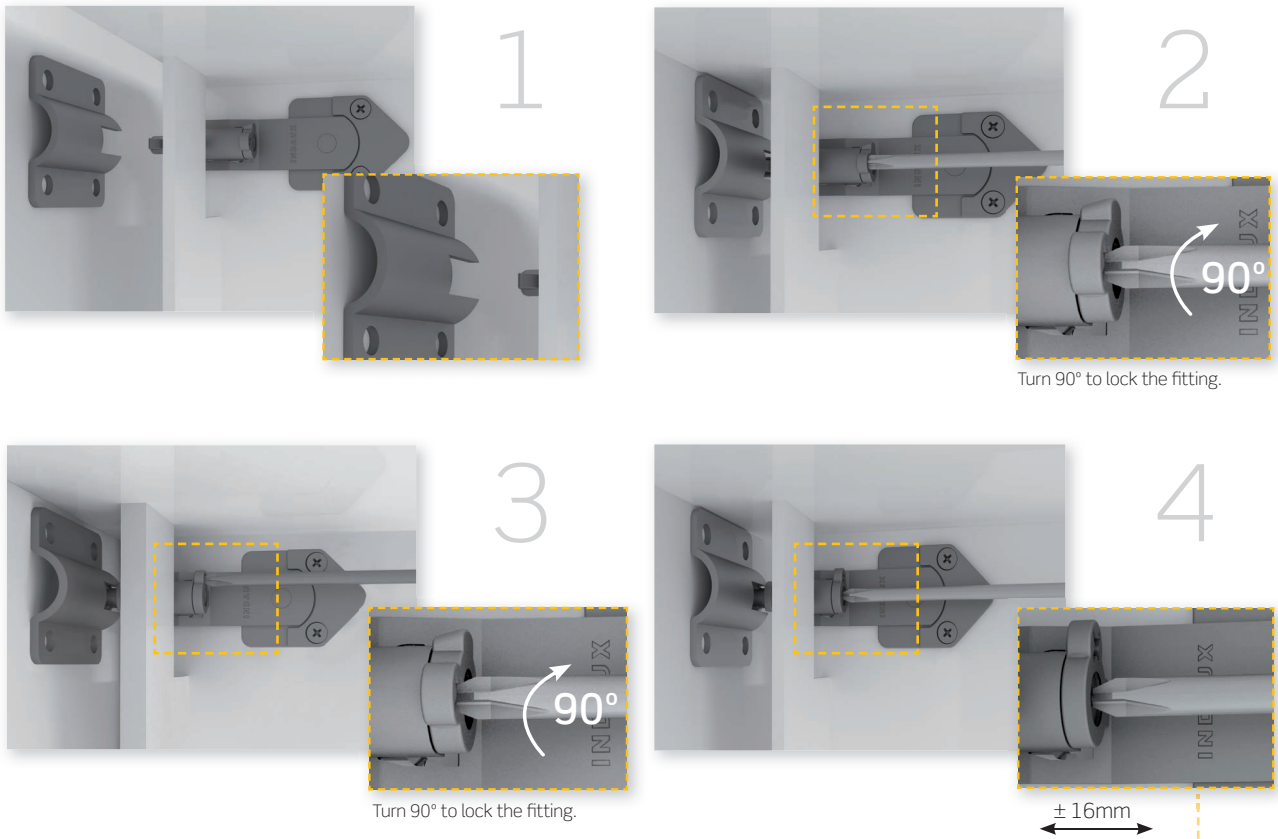

3 ASSEMBLY AND ADJUSTMENTS

Example using lower support fitting 3mm.

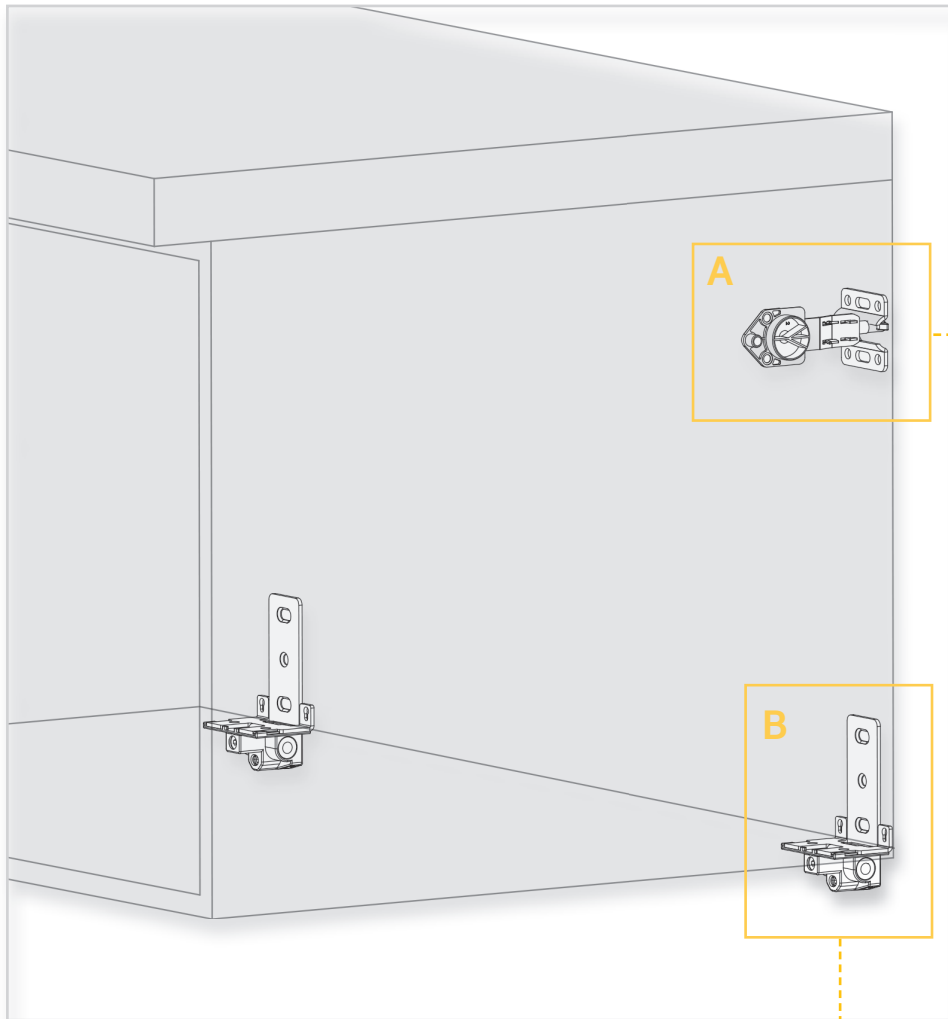

B

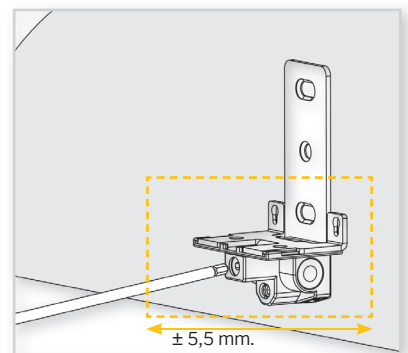
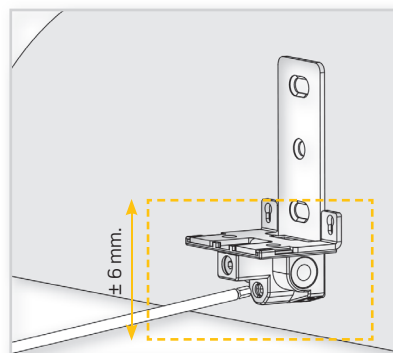
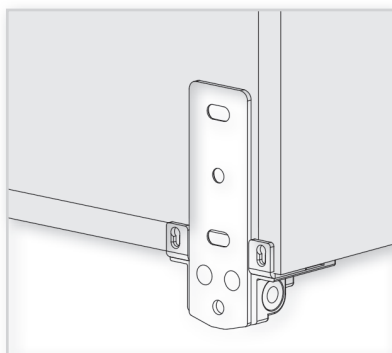

No previous machining of the module required before fixing the lower support.

A

