

Top hanging system

SWT003



SW sliding system

Top hanging sliding system - SWT003



- Top hanging sliding system
- Soft-close system
- 20-80KG/door loading capacity
- Damper with anti jumping and anti-decoupling
- 700-1500mm door width
- 16-46mm door thickness
- Door height ≤2500mm

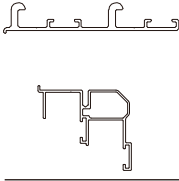

	Item	Quantity (2 doors)		Quantity (3 doors)	
		Single side soft-close	Double soft-close	Double soft-close	Triple soft-close
	Left upper runner for outside door	1 pc	1 pc	1 pc	1 pc
	Right upper runner for outside door	1 pc	1 pc	1 pc	1 pc
	Left upper runner for inside door	1 pc	1 pc	2 pcs	2 pcs
	Right upper runner for inside door	1 pc	1 pc	2 pcs	2 pcs
	Lower runner for outside door	2 pcs	2 pcs	2 pcs	2 pcs
	Lower runner for inside door	2 pcs	2 pcs	4 pcs	4 pcs
	Upper damper	2 pcs	4 pcs	4 pcs	6 pcs
	Lower damper	2 pcs	4 pcs	4 pcs	4 pcs
	Upper stopper	2 pcs	4 pcs	4 pcs	4 pcs
	Anti pinch device	1 pc	1 pc	2 pcs	2 pcs
	Anti collide stopper	0 pc	0 pc	0 pc	1 pc
	Position template	1 pc	1 pc	1 pc	1 pc
Item No.		SWT003-1	SWT003-2	SWT003-3	SWT003-4

	Item	Item No.	Remark
	Upper and lower rail	SWT03-R	3000mm length;

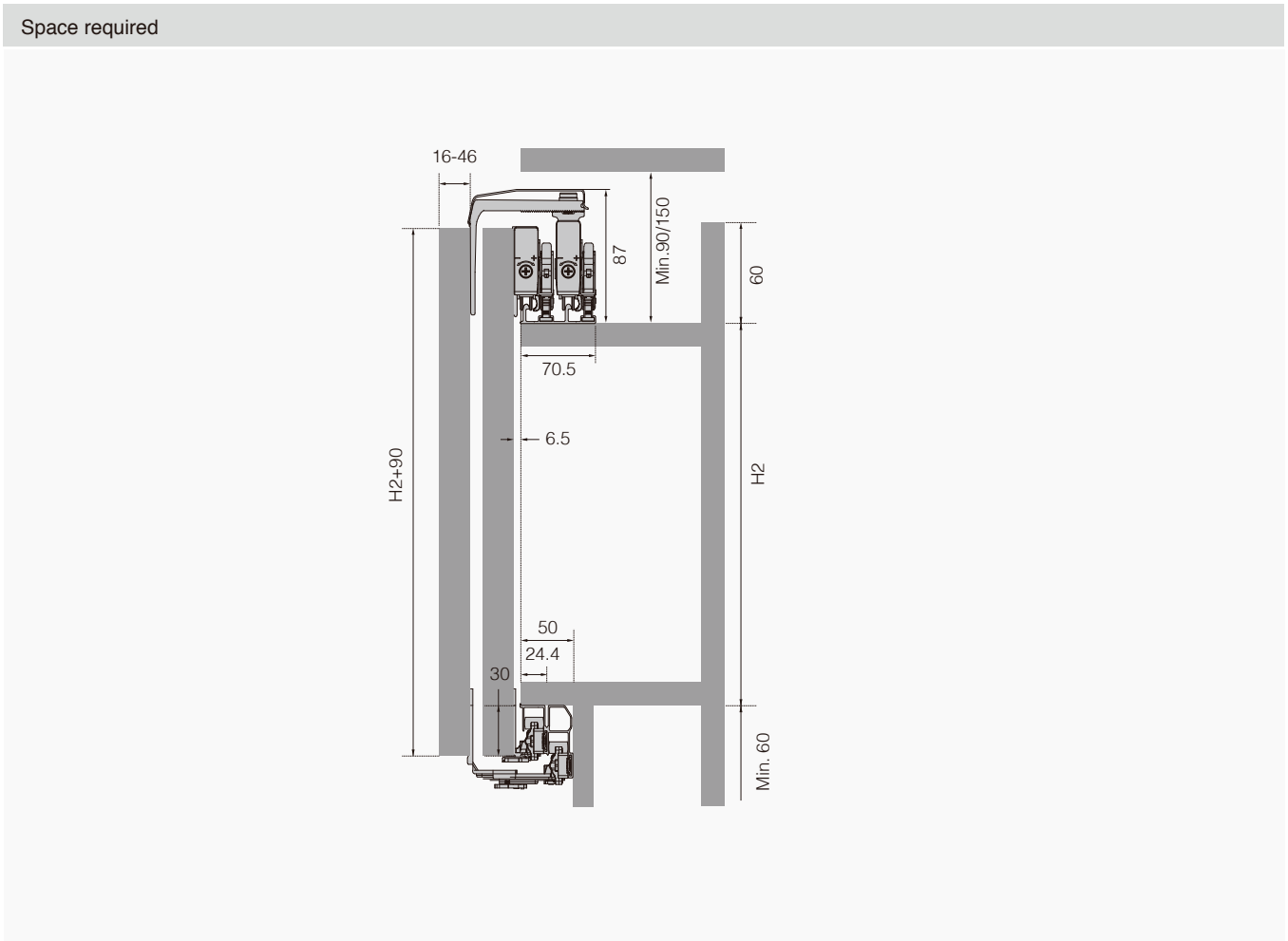
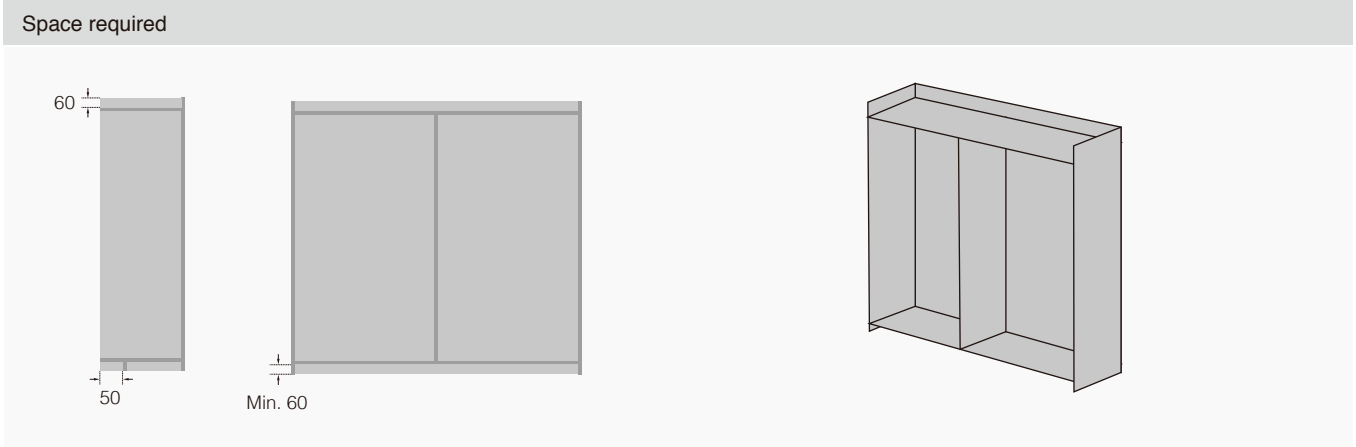

Installation dimension of doors

Single side soft close for 2 doors

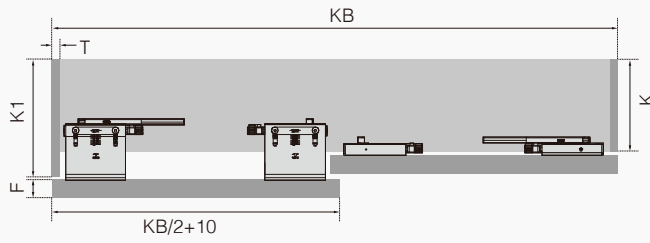

T: Thickness of side panel
KB: Cabinet width
F: Thickness of front panel
 $K1=K+T+8$

Double soft close for 2 doors

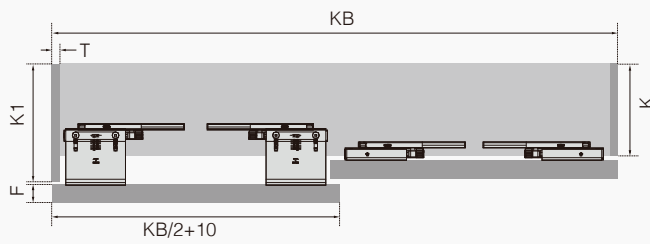

Double soft close for 3 doors

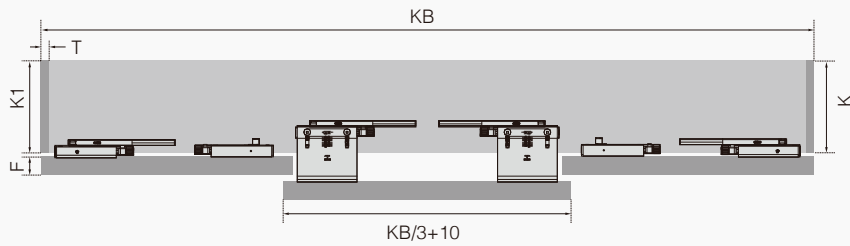

Triple soft close for 3 doors

